



Concorde Food Equipment Wholesalers

106 Fairbank Road
Clayton South
VIC 3169

Phone: (03) 9551 3034

Fax: (03) 9551 7656

Email: sales@concordefe.com.au



TITAN



EDITION 7
HOSPITALITY
EQUIPMENT
GUIDE



Concorde
FOOD EQUIPMENT WHOLESALERS

www.concordefe.com
For Service and Repairs
www.concordeservice.com.au

COMMERCIAL KITCHEN EQUIPMENT SPECIALISTS



*Cooking
Equipment*

TITAN

Shelving



*Frying
Equipment*



Ovens



Refrigeration



*Italian
Refrigeration*



*Bakery
Equipment*



*Ware
Washing*



*Flat Packed
Stainless Steel*



*Tandoori
Ovens*



*Counter Line
Equipment*



Rotisserie

Concorde
FOOD EQUIPMENT WHOLESALERS

- International Brands
- Wide range of foodservice products
- Up to 3 year Warranty

INTERNATIONAL BRANDS

QUALITY COMPONENTS !

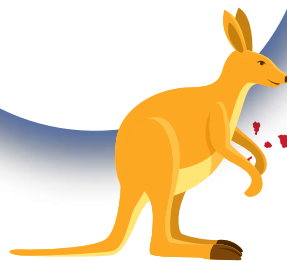

**WIDE RANGE OF FOOD SERVICE PRODUCTS
UP TO 3 YEARS WARRANTY**



OXFORD
series

GAS COOKING EQUIPMENT

Cooktops

Ovens

BBQ Burners Grill / Hotplate

Noodle Cookers

Fryers

Steamers

GAS DEEP FRYERS

400 Tube Fryer

600 Tube Fryer

- Flame failure device fitted as standard - Modified trivet for maximum gas burner efficiency
- Available in Natural Gas and LPG - Modified trivet for maximum gas burner efficiency
- Available in Natural Gas and LPG



3 YEAR WARRANTY (3 YEAR PARTS 1 YEAR LABOUR)

2 BURNER GAS COOKTOP

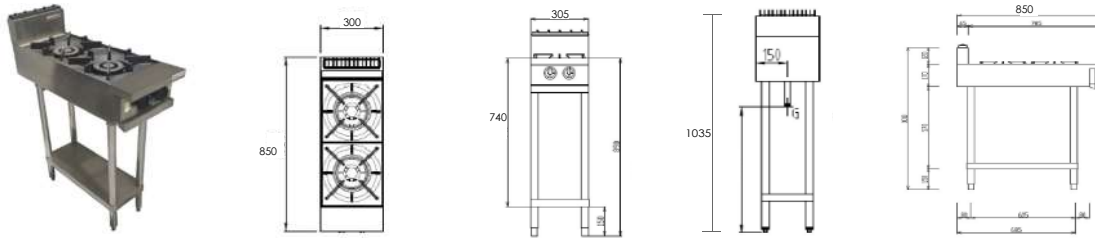

MODEL: 2BBT
(2 burners & shelf)

WEIGHT: 36 kg

OUTPUT: 58Mj/hr(NG) /52Mjhr(LPG)

(300Wx850Dx1035H)

MODEL: 2BBTP

WEIGHT: 36 kg

OUTPUT: 58Mj/hr(NG) /52Mjhr(LPG)

(2 burners with pilot light & shelf)

4 BURNER GAS COOKTOP

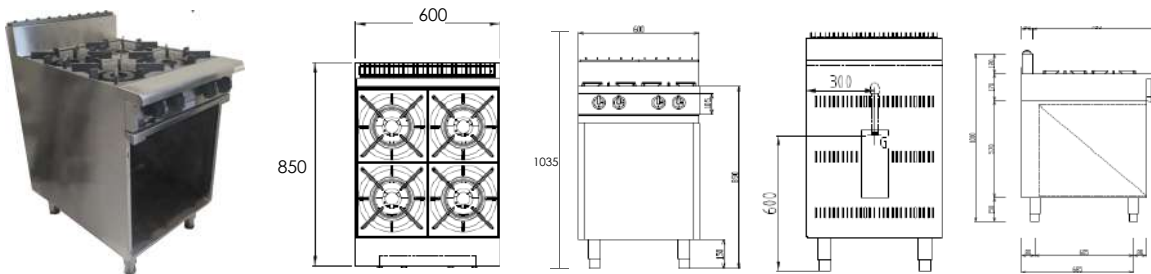

MODEL: 4BBT
(4 burners & shelf)

WEIGHT: 86 kg

OUTPUT: 116Mj/hr(NG)/104Mj/hr(LPG)

(600Wx850Dx1035H)

MODEL: 4BBTP

WEIGHT: 86 kg

OUTPUT: 116Mj/hr(NG)/104Mj/hr(LPG)

(4 burners with pilot light & shelf)



MODEL: 4BBT-3H
(2 burners, 300mm hotplate & shelf)

WEIGHT: 106 kg

OUTPUT: 116Mj/hr(NG)/104Mj/hr(LPG)

(600Wx850Dx1035H)

MODEL: 4BBTP-3H

WEIGHT: 106 kg

OUTPUT: 116Mj/hr(NG)/104Mj/hr(LPG)

(2 burners, 300mm hotplate with pilot light & shelf)

6 BURNER GAS COOKTOP

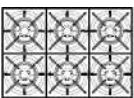
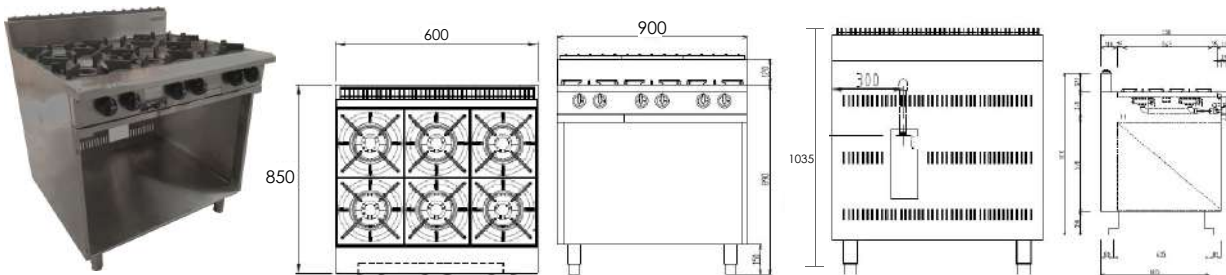

MODEL: 6BBT
(6 burners & shelf)

WEIGHT: 125 kg

OUTPUT: 174Mj/hr(NG)/156Mj/hr(LPG)

(900Wx850Dx1035H)

MODEL: 6BBTP

WEIGHT: 125 kg

OUTPUT: 174Mj/hr(NG)/156Mj/hr(LPG)

(6 burners with pilot light & shelf)

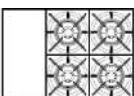

MODEL: 6BBT-3H
(4 burners, 300mm hotplate & shelf)

WEIGHT: 135 kg

OUTPUT: 174Mj/hr(NG)/156Mj/hr(LPG)

(900Wx850Dx1035H)

MODEL: 6BBTP-3H

WEIGHT: 135 kg

OUTPUT: 174Mj/hr(NG)/156Mj/hr(LPG)

(4 burners, 300mm hotplate with pilot light & shelf)

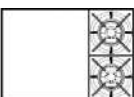

MODEL: 6BBT-6H
(2 burners, 600mm hotplate & shelf)

WEIGHT: 155 kg

OUTPUT: 174Mj/hr(NG)/156Mj/hr(LPG)

(900Wx850Dx1035H)

MODEL: 6BBTP-6H

WEIGHT: 155 kg

OUTPUT: 174Mj/hr(NG)/156Mj/hr(LPG)

(2 burners, 600mm hotplate with pilot light & shelf)





- Flame failure device fitted as standard - Modified trivet for maximum gas burner efficiency
 - Available in Natural Gas and LPG - Flame failure device fitted as standard - Modified trivet for maximum gas burner efficiency - Available in Natural Gas and LPG

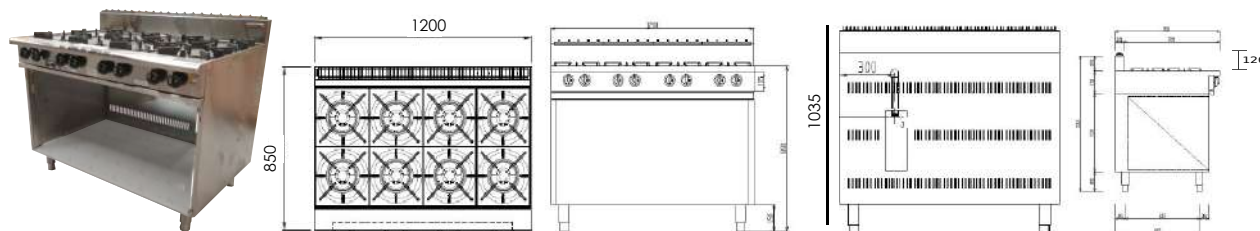

3 YEAR WARRANTY (3 YEAR PARTS 1 YEAR LABOUR)

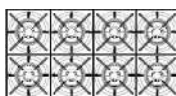
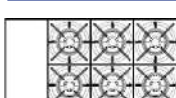
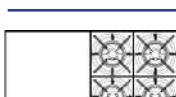
8 BURNER GAS COOKTOP



	MODEL: 8BBT (8 burners & shelf)	WEIGHT: 160 kg	OUTPUT: 232Mj/hr(NG)/208Mj/hr(LPG)	(1200Wx850Dx1035H)
	MODEL: 8BBTP (8 burners with pilot light & shelf)	WEIGHT: 160 kg	OUTPUT: 232Mj/hr(NG)/208Mj/hr(LPG)	(1200Wx850Dx1035H)
	MODEL: 8BBT-3H (6 burners, 300mm hotplate & shelf)	WEIGHT: 170 kg	OUTPUT: 232Mj/hr(NG)/208Mj/hr(LPG)	(1200Wx850Dx1035H)
	MODEL: 8BBTP-3H (6 burners, 300mm hotplate with pilot light & shelf)	WEIGHT: 170 kg	OUTPUT: 232Mj/hr(NG)/208Mj/hr(LPG)	(1200Wx850Dx1035H)
	MODEL: 8BBT-6H (4 burners, 600mm hotplate & shelf)	WEIGHT: 180 kg	OUTPUT: 232Mj/hr(NG)/208Mj/hr(LPG)	(1200Wx850Dx1035H)
	MODEL: 8BBTP-6H (4 burners, 600mm hotplate with pilot light & shelf)	WEIGHT: 180 kg	OUTPUT: 232Mj/hr(NG)/208Mj/hr(LPG)	(1200Wx850Dx1035H)

ACCESSORIES

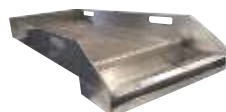

Drop on hot plate (19 mm mild steel plate) stainless steel sides with Handles - Includes oil catchment tray. Covers two burners on the Oxford range.

MODEL: BBT PLT

DIMENSIONS: 290Wx700D

- 2 shelves in oven - Flame failure device fitted as standard - Modified trivet for maximum gas burner efficiency - Available in Natural Gas and LPG



3 YEAR WARRANTY (3 YEAR PARTS 1 YEAR LABOUR)

4 BURNER GAS COOKTOP WITH IN-BUILT GAS OVEN

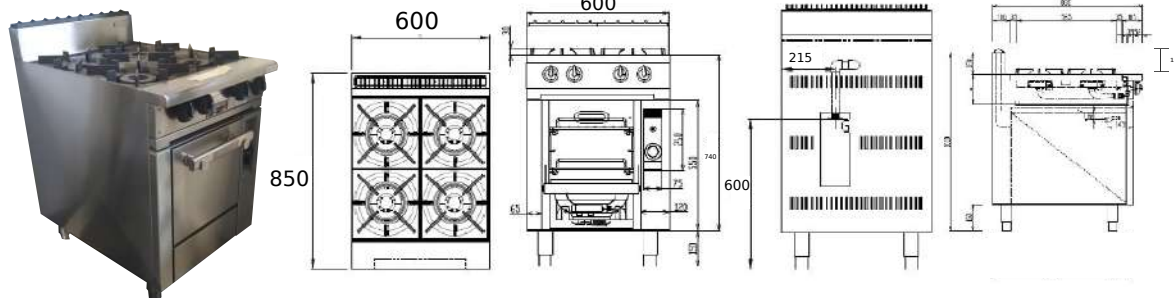

MODEL: 4BBT-OV
(4 burners with gas oven)

WEIGHT: 138 kg

OUTPUT: 136Mj/hr (NG)/120Mj/hr (LPG)

(600Wx850Dx1010H)

MODEL: 4BBTP-OV
(4 burners with pilot light & gas oven)

WEIGHT: 138 kg

OUTPUT: 140Mj/hr (NG)/124Mj/hr (LPG)

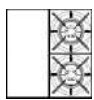

MODEL: 4BBT-OV-3H
(2 burners, 300mm hotplate with gas oven)

WEIGHT: 150 kg

OUTPUT: 140Mj/hr (NG)/124Mj/hr (LPG)

(600Wx850Dx1010H)

MODEL: 4BBTP-OV-3H
(2 burners, 300mm hotplate with pilot light & gas)

WEIGHT: 150 kg

OUTPUT: 140Mj/hr (NG)/124Mj/hr (LPG)

6 BURNER GAS COOKTOP WITH IN-BUILT GAS OVEN

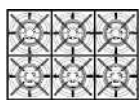
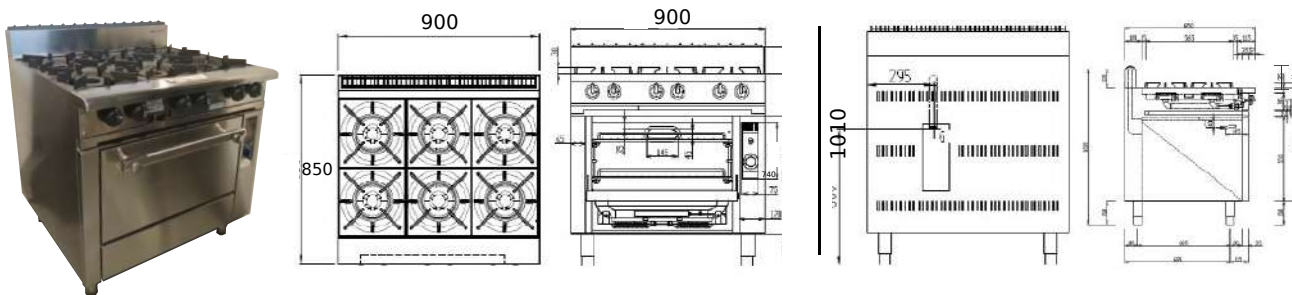

MODEL: 6BBT-OV
(6 burners with gas oven)

WEIGHT: 230 kg

OUTPUT: 214Mj/hr (NG)/186Mj/hr (LPG)

(900Wx850Dx1010H)

MODEL: 6BBTP-OV
(6 burners with pilot light & gas oven)

WEIGHT: 230 kg

OUTPUT: 220Mj/hr (NG)/186Mj/hr (LPG)

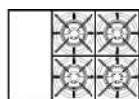

MODEL: 6BBT-OV-3H
(4 burners, 300mm hotplate with gas oven)

WEIGHT: 240 kg

OUTPUT: 220Mj/hr (NG)/186Mj/hr (LPG)

(900Wx850Dx1010H)

MODEL: 6BBTP-OV-3H
(4 burners, 300mm hotplate with pilot light & gas oven)

WEIGHT: 240 kg

OUTPUT: 220Mj/hr (NG)/186Mj/hr (LPG)

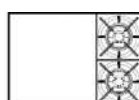

MODEL: 6BBT-OV-6H
(2 burners, 600mm hotplate with gas oven)

WEIGHT: 250 kg

OUTPUT: 220Mj/hr (NG)/186Mj/hr (LPG)

(900Wx850Dx1010H)

MODEL: 6BBTP-OV-6H
(2 burners, 600mm hotplate with pilot light & gas oven)

WEIGHT: 250 kg

OUTPUT: 220Mj/hr (NG)/186Mj/hr (LPG)

6 BURNER GAS COOKTOP WITH ROYSTON® ROY-8A ELECTRIC CONVECTION OVEN

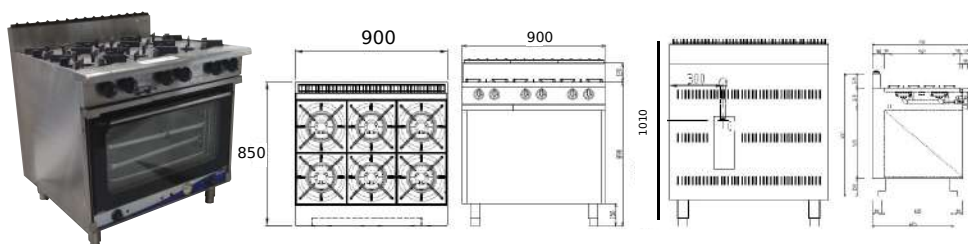

MODEL: 6BBTL-OV15A

DIMENSIONS: 900Wx850Dx1035H

OUTPUT: Cooktop: 174Mj/hr(NG)

/156Mj/hr(LPG) **Oven:** 3.6kW

WEIGHT: 192 kg

- Flame failure device fitted as standard - Modified trivet for maximum gas burner efficiency
- Available in Natural Gas and LPG - Electric Convection Oven: - Double glazed glass door - Steam option included - Chamber dimensions: 860Wx360Dx460H - 240V 15A 50Hz



- 2 shelves in oven - Flame failure device fitted as standard - Modified trivet for maximum gas burner efficiency.



3 YEAR WARRANTY (3 YEAR PARTS 1 YEAR LABOUR)

8 BURNER GAS COOKTOP WITH IN-BUILT GAS OVEN (ON LEFT HAND SIDE) AND CABINET

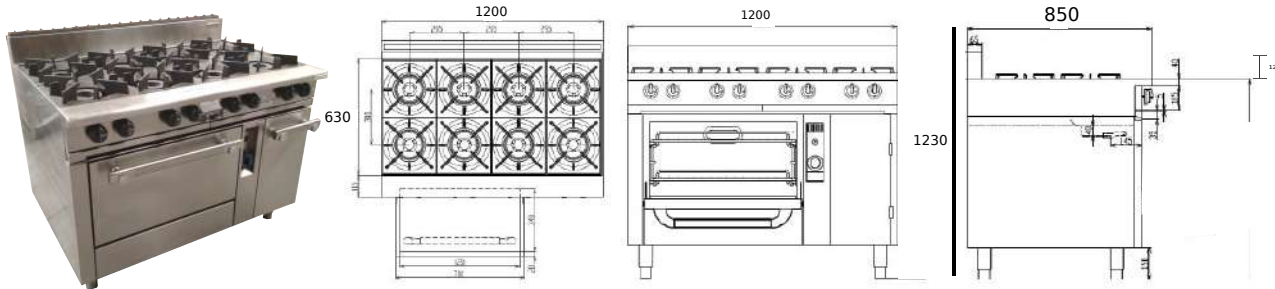

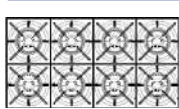
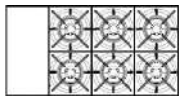
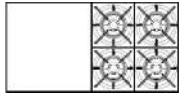
	MODEL: 8BBT-OV-L (8 burners with gas oven left)	WEIGHT: 300 kg	OUTPUT: 267Mj/hr(NG)/238Mj/hr(LPG)	(1200Wx850Dx1230H)
	MODEL: 8BBTP-OV-L (8 burners with pilot light & gas oven)	WEIGHT: 320 kg	OUTPUT: 267Mj/hr(NG)/238Mj/hr(LPG)	
	MODEL: 8BBT-OV-L3H (6 burners, 300mm hotplate with gas oven left)	WEIGHT: 330 kg	OUTPUT: 267Mj/hr(NG)/238Mj/hr(LPG)	(1200Wx850Dx1230H)
	MODEL: 8BBTP-OV-L3H (6 burners, 300mm hotplate with pilot light & gas oven left)	WEIGHT: 330 kg	OUTPUT: 267Mj/hr(NG)/238Mj/hr(LPG)	
	MODEL: 8BBT-OV-L6H (4 burners, 600mm hotplate with gas oven left)	WEIGHT: 330 kg	OUTPUT: 267Mj/hr(NG)/238Mj/hr(LPG)	(1200Wx850Dx1230H)
	MODEL: 8BBTP-OV-L6H (4 burners, 600mm hotplate with pilot light & gas oven left)	WEIGHT: 330 kg	OUTPUT: 267Mj/hr(NG)/238Mj/hr(LPG)	

8 BURNER GAS COOKTOP WITH IN-BUILT GAS OVEN (ON RIGHT HAND SIDE) AND CABINET

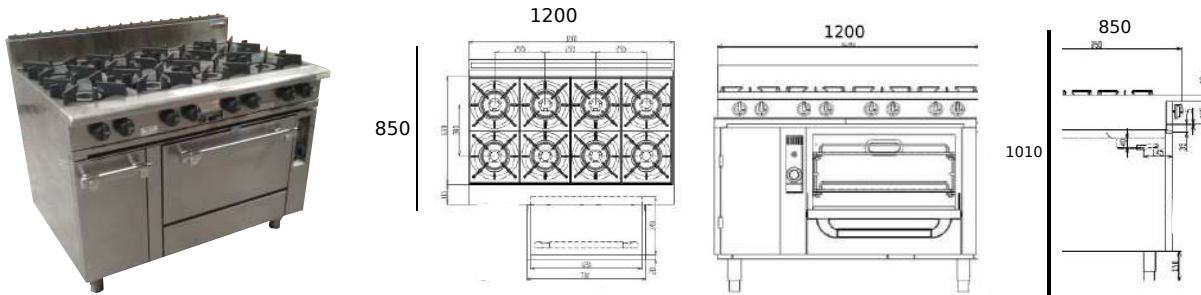

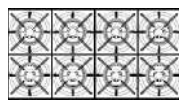
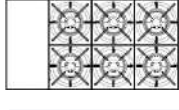
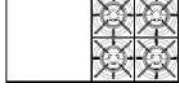
	MODEL: 8BBT-OV-R (8 burners with gas oven right)	WEIGHT: 300 kg	OUTPUT: 267Mj/hr(NG)/238Mj/hr(LPG)	(1200Wx850Dx1010H)
	MODEL: 8BBTP-OV-R (8 burners with pilot light & gas oven right)	WEIGHT: 300 kg	OUTPUT: 267Mj/hr(NG)/238Mj/hr(LPG)	
	MODEL: 8BBT-OV-R3H (6 burners, 300mm hotplate with gas oven right)	WEIGHT: 320 kg	OUTPUT: 267Mj/hr(NG)/238Mj/hr(LPG)	(1200Wx850Dx1010H)
	MODEL: 8BBTP-OV-R3H (6 burners, 300mm hotplate with pilot light & gas oven right)	WEIGHT: 320 kg	OUTPUT: 267Mj/hr(NG)/238Mj/hr(LPG)	
	MODEL: 8BBT-OV-R6H (4 burners, 600mm hotplate & gas oven right)	WEIGHT: 325 kg	OUTPUT: 267Mj/hr(NG)/238Mj/hr(LPG)	(1200Wx850Dx1010H)
	MODEL: 8BBTP-OV-R6H (4 burners, 600mm hotplate with pilot light & gas oven right)	WEIGHT: 325 kg	OUTPUT: 267Mj/hr(NG)/238Mj/hr(LPG)	

- 2 shelves in oven - Flame failure device fitted as standard - Modified trivet for maximum gas burner efficiency



3 YEAR WARRANTY (3 YEAR PARTS 1 YEAR LABOUR)

8 BURNER COOKTOP WITH 2 GAS OVENS

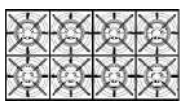
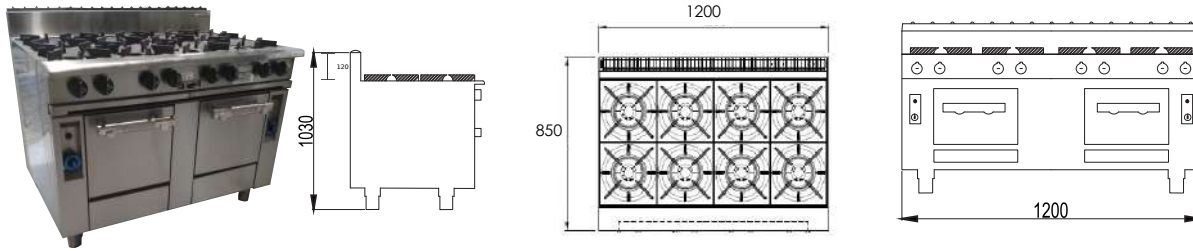

MODEL: 8BBT-2OV
(8 burners & 2 gas ovens)

WEIGHT: 280 kg

OUTPUT: 272Mj/hr(NG)/240Mj/hr(LPG)

(1200xWx850Dx1030H)

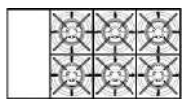

MODEL: 8BBT-2OV-3H
(6 burners, 300mm hotplate & 2 gas ovens)

WEIGHT: 290 kg

OUTPUT: 272Mj/hr(NG)/240Mj/hr(LPG)

(1200xWx850Dx1030H)

MODEL: 8BBTP-2OV
(8 burners with pilot light & 2 gas ovens)

WEIGHT: 280 kg

OUTPUT: 272Mj/hr(NG)/240Mj/hr(LPG)

MODEL: 8BBTP-2OV-3H
(6 burners, 300mm hotplate with pilot light & 2 gas ovens)

WEIGHT: 300 kg

OUTPUT: 272Mj/hr(NG)/240Mj/hr(LPG)

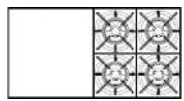

MODEL: 8BBT-2OV-6H
(4 burners, 600mm hotplate & 2 gas ovens)

WEIGHT: 300 kg

OUTPUT: 272Mj/hr(NG)/240Mj/hr(LPG)

(1200xWx850Dx1030H)

MODEL: 8BBTP-2OV-6H
(4 burners, 600mm hotplate with pilot light & 2 gas ovens)

WEIGHT: 300 kg

OUTPUT: 272Mj/hr(NG)/240Mj/hr(LPG)

RANGE MATCH IN FILL BENCH



MODEL: 03-300L

DIMENSIONS: 300Wx760Dx900H

WEIGHT: 13 kg

MODEL: 03-450L

DIMENSIONS: 450Wx760Dx900H

WEIGHT: 20 kg

MODEL: 03-600L

DIMENSIONS: 600Wx760Dx900H

WEIGHT: 25 kg

YUM CHA ELECTRIC TROLLEY

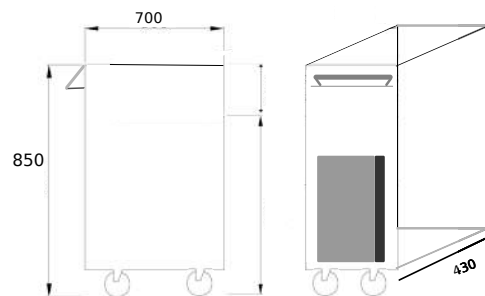

MODEL: Dim Sim Trolley-E

DIMENSIONS: 700Wx430Dx850H

OUTPUT: 240V (10 Amps)

WEIGHT: 35 kg

3 YEAR WARRANTY
(3 YEAR PARTS 1 YEAR LABOUR)



This is an electric trolley with S/S Hinge Door-- EGO Thermostat 110 C-- power lined with S/S ball Valve and Australian Cables -- 125mm PU castor with 2 brakes provided with firelighter and Wooden crate package - Electric & solid fuel.

400MM GAS FRYER

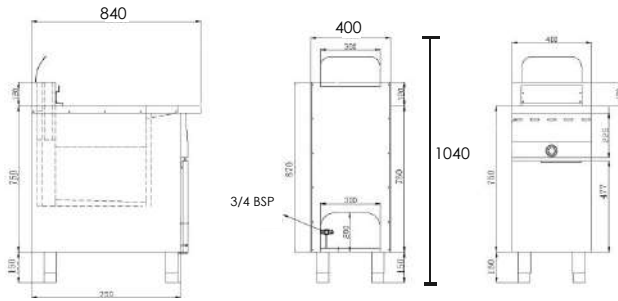

MODEL: GFC400

DIMENSIONS: 400Wx840Dx1040H

OUTPUT: 100Mj/hr(NG)/90Mj/hr(LPG)

WEIGHT: 80 kg

3 YEAR WARRANTY
(3 YEAR PARTS 1 YEAR LABOUR)



- Stainless steel tank gas fryer - Tank capacity: 27 litres - Includes two baskets - Available in Natural Gas or LPG

600MM GAS FRYER

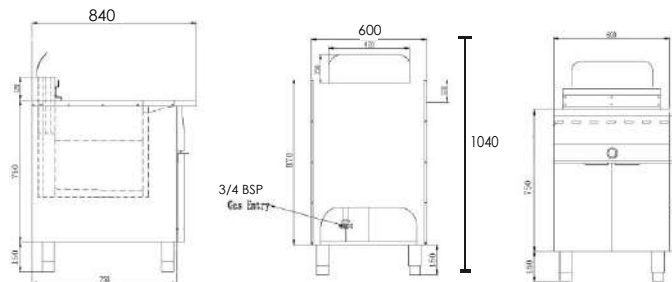

MODEL: GF F 600

DIMENSIONS: 600Wx840Dx1040H

OUTPUT: 100Mj/hr(NG)/90Mj/hr(LPG)

WEIGHT: 93 kg

3 YEAR WARRANTY
(3 YEAR PARTS 1 YEAR LABOUR)



- Stainless steel tank gas fryer - Tank capacity: 36 litres - Includes three baskets - Available in Natural Gas or LPG

SINGLE TANK 400MM TUBE FRYER

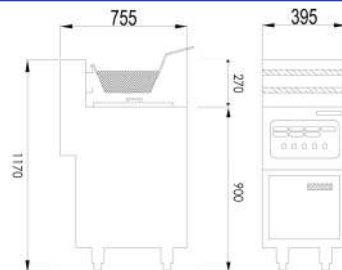

MODEL: 400 TUBE FRYER

DIMENSIONS: 395Wx755Dx900+270H

OUTPUT: 68Mj/hr(NG)/65Mj/hr(LPG)

WEIGHT: 63 kg

3 YEAR WARRANTY
(3 YEAR PARTS 1 YEAR LABOUR)



- Single tank - Advanced thermostatic valve - Electric ignition and thermocouple flame failure device - Over temperature cut-out device

TWIN TANK 600MM TUBE FRYER

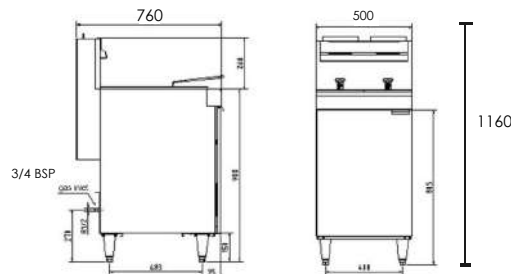

MODEL: 600 TUBE FRYER

DIMENSIONS: 500Wx760Dx1160H

OUTPUT: 96Mj/hr(NG)/100Mj/hr(LPG)

WEIGHT: 91 kg

3 YEAR WARRANTY
(3 YEAR PARTS 1 YEAR LABOUR)



- Twin tank - Advanced thermostatic valve - Electric ignition and thermocouple flame failure device - Over temperature cut-out device

SINGLE TANK ELECTRIC FRYER

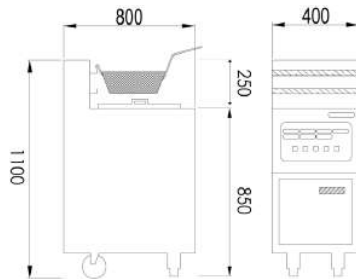

MODEL: EF400

DIMENSIONS: 550Wx950Dx1300H

OUTPUT: 3 PHASE 18kw

WEIGHT: 90 kg

3 YEAR WARRANTY
(3 YEAR PARTS 1 YEAR LABOUR)



- Single tank - Two fryer baskets - Crumb screen - Drain oil extension pipe - Easy to use control panel

TWIN TANK ELECTRIC FRYER

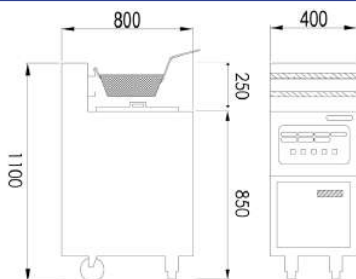

MODEL: EF400-2VAT

DIMENSIONS: 400Wx800Dx850+250H

OUTPUT: 3 PHASE 2x9kw

WEIGHT: 95 kg

3 YEAR WARRANTY
(3 YEAR PARTS 1 YEAR LABOUR)



- Twin tanks - Two fryer baskets - Crumb screen - Drain oil extension pipe - Easy to use control panel

FISH PLATES



MODEL: FP400

DIMENSIONS: 430Wx290H

MODEL: FP600

DIMENSIONS: 490Wx430H



Did you know?

You can significantly improve the quality and life of your fryer oil by using a Royston® OF-28 Oil Filter and Magnesol® Filter Powder. To find out more, please see the Royston® Catalogue.



- Removable basting rail included - Shelf underneath for added support and stability - Basting bar spaced at 85mm to suit GN 1/9 pans - Available in Natural Gas and LPG
 * Partial Hot Plate Available



3 YEAR WARRANTY (3 YEAR PARTS 1 YEAR LABOUR)

1 BURNER BBQ CHARGRILL

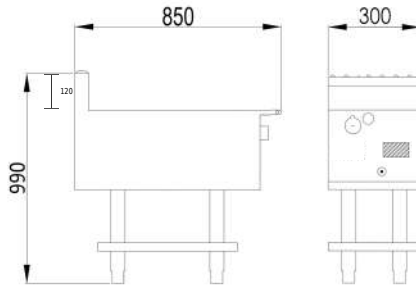

MODEL: RCGD01
(300mm grill & shelf)

WEIGHT: 35 kg

OUTPUT: 30Mj/hr(NG)/ 17.8Mj/hr(LPG)

(300Wx850Dx990H)



MODEL: RCGD01S
(300mm hotplate & shelf)

WEIGHT: 45 kg

OUTPUT: 19Mj/hr(NG)/ 17.8Mj/hr(LPG)

(300Wx850Dx990H)

2 BURNER BBQ CHARGRILL

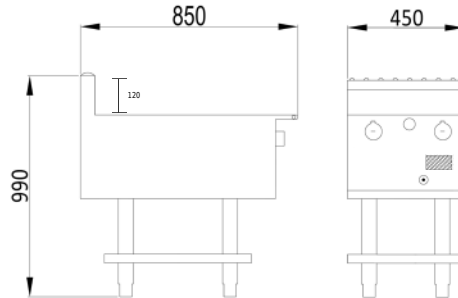

MODEL: RCGD02
(450mm grill & shelf)

WEIGHT: 45 kg

OUTPUT: 60Mj/hr(NG)/35.6Mj/hr(LPG)

(450Wx850Dx990H)



MODEL: RCGD02S
(450mm hotplate & shelf)

WEIGHT: 55 kg

OUTPUT: 38Mj/hr(NG)/35.6Mj/hr(LPG)

(450Wx850Dx990H)

3 BURNER BBQ CHARGRILL

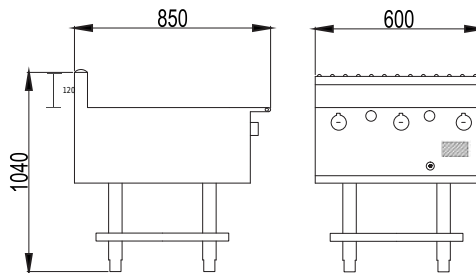

MODEL: RCGD03
(600mm grill & shelf)

WEIGHT: 65 kg

OUTPUT: 90Mj/hr(NG)/53.4Mj/hr(LPG)

(600Wx850Dx1040H)



MODEL: RCGD03-3H
(300mm grill, 300mm hotplate & shelf)

WEIGHT: 75 kg

OUTPUT: 90Mj/hr(NG)/ 53.4Mj/hr(LPG)

(600Wx850Dx1040H)



MODEL: RCGD03S
(600mm hotplate & shelf)

WEIGHT: 85 kg

OUTPUT: 57Mj/hr(NG)/53.4Mj/hr(LPG)

(600Wx850Dx1040H)

- Removable basting rail included - Shelf underneath for added support and stability - Basting bar spaced at 85mm to suit GN 1/9 pans - Available in Natural Gas and LPG

* Partial Hot Plate Available



3 YEAR WARRANTY (3 YEAR PARTS 1 YEAR LABOUR)

4 BURNER BBQ CHARGRILL

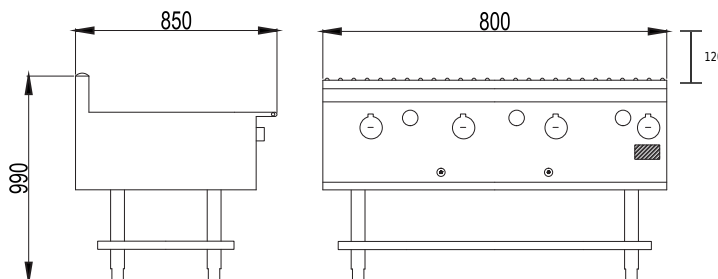

MODEL: RCGD04 **WEIGHT:** 103 kg **OUTPUT:** 120Mj/hr(NG)/71.2Mj/hr(LPG) (800Wx850Dx990H)
(800mm grill & shelf)



MODEL: RCGD04-47H **WEIGHT:** 113 kg **OUTPUT:** 120Mj/hr(NG)/71.2Mj/hr(LPG) (800Wx850Dx990H)
(330mm grill, 470mm hotplate & shelf)



MODEL: RCGD04S **WEIGHT:** 123 kg **OUTPUT:** 76Mj/hr(NG)/71.2Mj/hr(LPG) (800Wx850Dx990H)
(800mm hotplate & shelf)

5 BURNER BBQ CHARGRILL

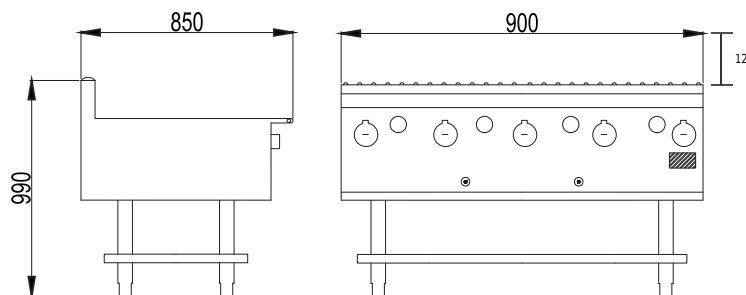

MODEL: RCGD05 **WEIGHT:** 120 kg **OUTPUT:** 150Mj/hr(NG)/89Mj/hr(LPG) (900Wx850Dx990H)
(900mm grill & shelf)

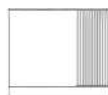

MODEL: RCGD05-6H **WEIGHT:** 130 kg **OUTPUT:** 150Mj/hr(NG)/89Mj/hr(LPG) (900Wx850Dx990H)
(330mm grill, 600mm hotplate & shelf)



MODEL: RCGD05S **WEIGHT:** 145 kg **OUTPUT:** 95Mj/hr(NG)/89Mj/hr(LPG) (900Wx850Dx990H)
(900mm hotplate & shelf)

- Removable basting rail included - Shelf underneath for added support and stability - Basting bar spaced at 85mm to suit GN 1/9 pans - Available in Natural Gas and LPG
 * Partial Hot Plate Available



3 YEAR WARRANTY (3 YEAR PARTS 1 YEAR LABOUR)

6 BURNER BBQ CHARGRILL

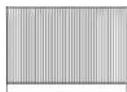
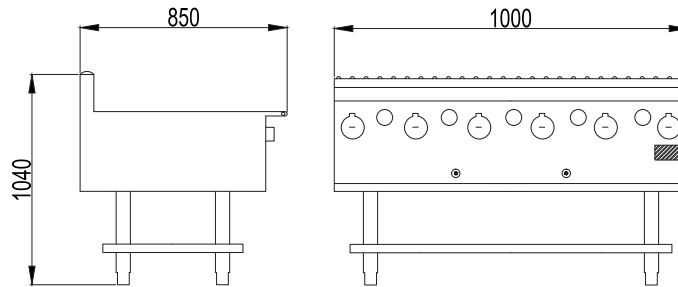

MODEL: RCGD06 (1000mm grill & shelf) **WEIGHT:** 135 kg **OUTPUT:** 180Mj/hr(NG)/106.8Mj/hr(LPG) (1000Wx850Dx1040H)



MODEL: RCGD06-6H (400mm grill, 600mm hotplate & shelf) **WEIGHT:** 145 kg **OUTPUT:** 180Mj/hr(NG)/106.8Mj/hr(LPG) (1000Wx850Dx1040H)



MODEL: RCGD06S (1000mm hotplate & shelf) **WEIGHT:** 155 kg **OUTPUT:** 114Mj/hr(NG)/106.8Mj/hr(LPG) (1000Wx850Dx1040H)

7 BURNER BBQ CHARGRILL

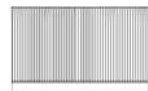
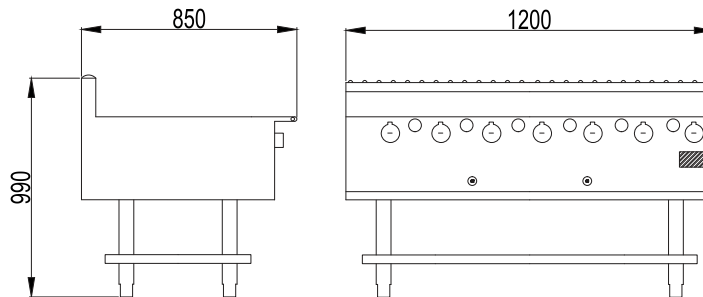

MODEL: RCGD07 (1200mm grill & shelf) **WEIGHT:** 160 kg **OUTPUT:** 210Mj/hr(NG)/124.6Mj/hr(LPG) (1200Wx850Dx990H)

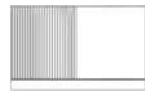

MODEL: RCGD07-6H (600mm grill, 600mm hotplate & shelf) **WEIGHT:** 170 kg **OUTPUT:** 210Mj/hr(NG)/124.6Mj/hr(LPG) (1200Wx850Dx990H)

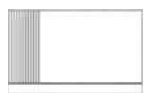

MODEL: RCGD07-9H (300mm grill, 900mm hotplate & shelf) **WEIGHT:** 180 kg **OUTPUT:** 210Mj/hr(NG)/124.6Mj/hr(LPG) (1200Wx850Dx990H)



MODEL: RCGD07S (1200mm hotplate & shelf) **WEIGHT:** 190 kg **OUTPUT:** 133Mj/hr(NG)/124.6Mj/hr(LPG) (1200Wx850Dx990H)

- Removable basting rail included - Shelf underneath for added support and stability - Basting bar spaced at 85mm to suit GN 1/9 pans - Available in Natural Gas and LPG
* Partial Hot Plate Available



3 YEAR WARRANTY (3 YEAR PARTS 1 YEAR LABOUR)

8 BURNER BBQ CHARGRILL

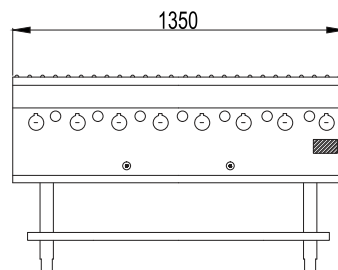
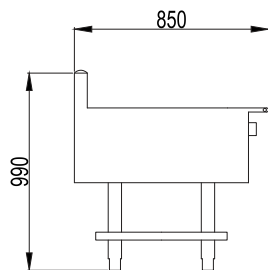

MODEL: RCGD08
(1350mm grill & shelf)

WEIGHT: 180 kg

OUTPUT: 240Mj/hr(NG)/142.4Mj/hr(LPG)

(1350Wx850Dx990H)



MODEL: RCGD08-75H
(600mm grill, 750mm hotplate & shelf)

WEIGHT: 190 kg

OUTPUT: 240Mj/hr(NG)/142.4Mj/hr(LPG)

(1350Wx850Dx990H)

9 BURNER BBQ CHARGRILL

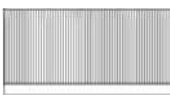
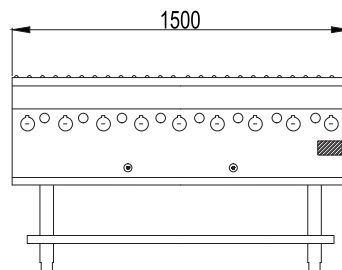
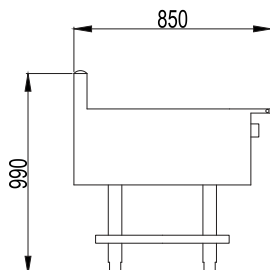

MODEL: RCGD09
(1500mm grill & shelf)

WEIGHT: 200 kg

OUTPUT: 270Mj/hr(NG)/160.2Mj/hr(LPG)

(1500Wx850Dx990H)

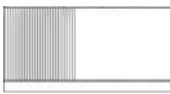

MODEL: RCGD09-88H
(620mm grill, 880mm hotplate & shelf)

WEIGHT: 210 kg

OUTPUT: 270Mj/hr(NG)/160.2Mj/hr(LPG)

(1500Wx850Dx990H)

ACCESSORIES



- Leg braces to suit RCGD series chargrills and hotplates

MODEL: RCGD BBQ LEG BRACE

DIMENSIONS: VARIOUS

PRICE: VARIOUS

RANGE MATCH IN FILL BENCH

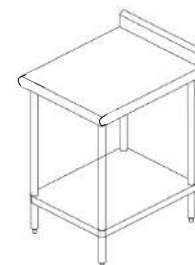
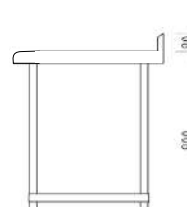
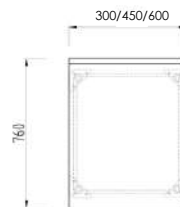

MODEL: 03-300L

DIMENSIONS: 300Wx760Dx900H

WEIGHT: 13 kg

MODEL: 03-450L

DIMENSIONS: 450Wx760Dx900H

WEIGHT: 20 kg

MODEL: 03-600L

DIMENSIONS: 600Wx760Dx900H

WEIGHT: 25 kg

DUCK OVEN

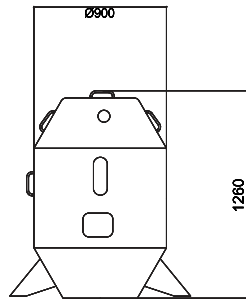

- Stainless steel construction - Double skin for better insulation - Efficient cast iron burner with venturi adjustment - Gas - Natural draught burner assembly - Thermometer - On off gas control - Safety valve with pilot function

MODEL: DO-900 3 PIECE MODEL
DIMENSIONS: 900Wx900Dx1260H
OUTPUT: 55Mj/hr
WEIGHT: 140 kg

3 YEAR WARRANTY
 (3 YEAR PARTS 1 YEAR LABOUR)



DUCK OVEN

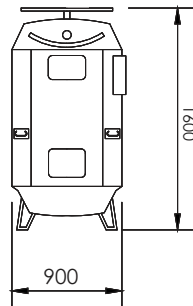

- Stainless steel construction - Double skin for better insulation - Efficient cast iron burner with venturi adjustment - Gas or charcoal - Natural draught burner assembly - Volcanic rock function included - Thermometer - On off gas control - Safety valve with pilot function

MODEL: DO-900-Door 1 PIECE MODEL
DIMENSIONS: 900Wx900Dx1600H
OUTPUT: 55Mj/hr
WEIGHT: 150 kg

3 YEAR WARRANTY
 (3 YEAR PARTS 1 YEAR LABOUR)



PIG OVEN

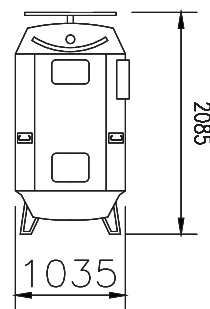

- Stainless steel construction - Double skin for better insulation - Efficient cast iron burner with venturi adjustment - Gas - Natural draught burner assembly - Thermometer - On off gas control - Safety valve with pilot function

MODEL: PO-1000 1 PIECE MODEL
DIMENSIONS: 1035Wx1035Dx1905H
OUTPUT: 55Mj/hr(NG)
WEIGHT: 180 kg

3 YEAR WARRANTY
 (3 YEAR PARTS 1 YEAR LABOUR)



CHARCOAL DUCK OVEN

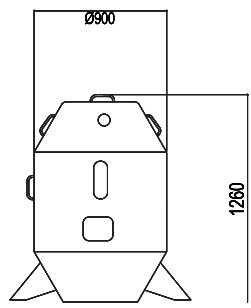

- Stainless steel construction - Double skin for better insulation - Thermometer - Suitable for charcoal.

MODEL: DO-900-C 3 PIECE MODEL
DIMENSIONS: 900Wx900Dx1260H
OUTPUT: 55Mj/hr
WEIGHT: 140 kg

3 YEAR WARRANTY
 (3 YEAR PARTS 1 YEAR LABOUR)



HIGH VOLUME 6 BASKET NOODLE PASTA COOKER

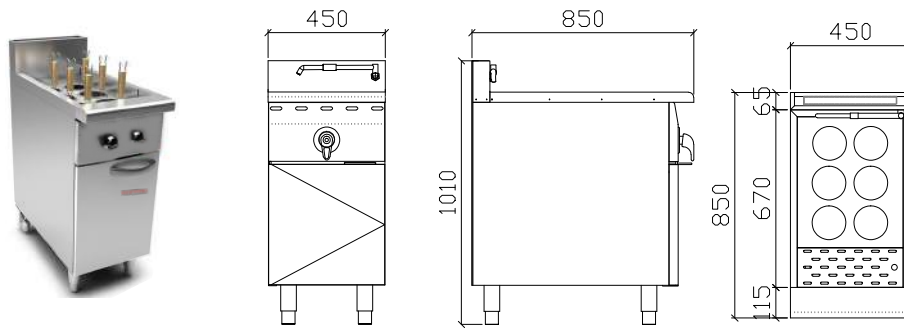

MODEL: 6NP

DIMENSIONS: 450Wx850Dx1010H

OUTPUT: 90Mj Natural gas/70 Mj LPG

WEIGHT: 60 kg

3 YEAR WARRANTY
(3 YEAR PARTS 1 YEAR LABOUR)



High volume 6 basket noodle pasta cooker. 450 wide to fit into tighter lineups.

6 BASKET NOODLE/PASTA COOKER

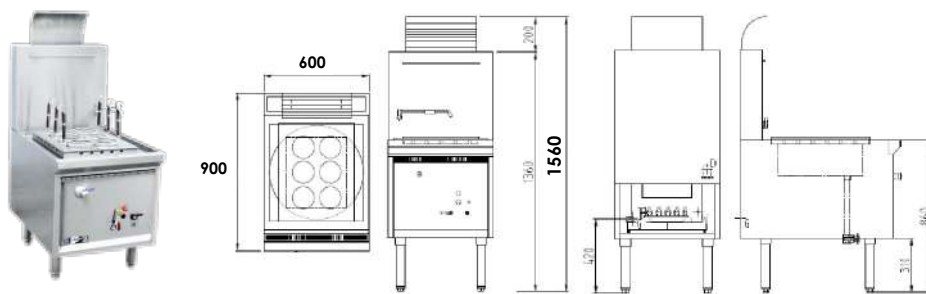

MODEL: 6BASKET-NC

DIMENSIONS: 600Wx900Dx1560H

OUTPUT: 80Mj/hr(NG)/70Mj/hr(LPG)

WEIGHT: 115 kg

3 YEAR WARRANTY
(3 YEAR PARTS 1 YEAR LABOUR)



- High quality construction using Italian gas controls and pilots - Flame failure device fitted as standard - Available in Natural Gas and LPG

6 BASKET NOODLE/3 BASKET PASTA COOKER - SINGLE TANK

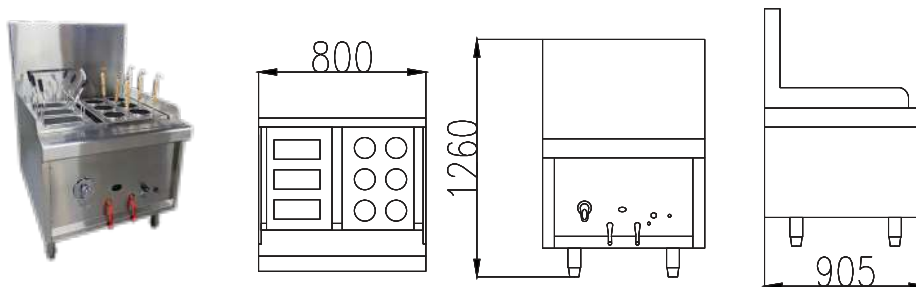

MODEL: 6N3P-1

DIMENSIONS: 800Wx900Dx1260H

OUTPUT: 160Mj/hr(NG)

WEIGHT: 115 kg

3 YEAR WARRANTY
(3 YEAR PARTS 1 YEAR LABOUR)



- Two 23 jet Mongolian burner - Adjustable Legs - Swivel laundry arm - Stainless steel single tank

6 BASKET NOODLE/3 BASKET PASTA COOKER - SPLIT TANK

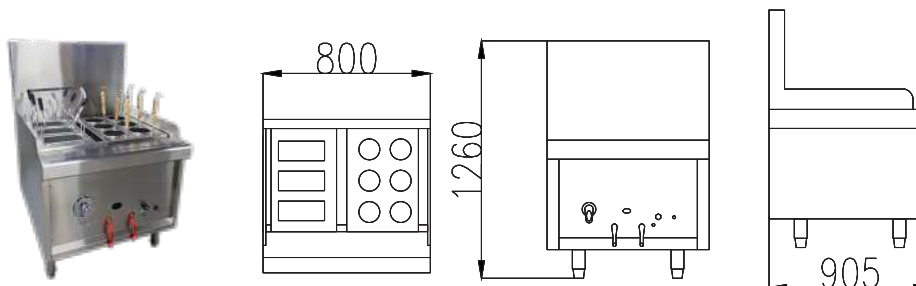

MODEL: 6N3P-2

DIMENSIONS: 800Wx900Dx1260H

OUTPUT: 160Mj/hr(NG)

WEIGHT: 115 kg

3 YEAR WARRANTY
(3 YEAR PARTS 1 YEAR LABOUR)



- Two 23 jet Mongolian burner - Adjustable Legs - Swivel laundry arm - Stainless steel twin tank

1 DOOR GAS STEAMER SMALL

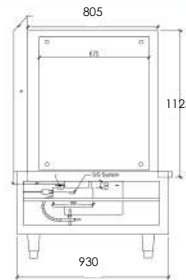
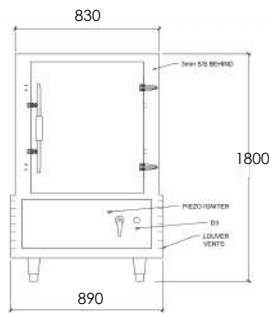

MODEL: FSGS-1

DIMENSIONS: 890Wx920Dx1810H

OUTPUT: 140 Mj

WEIGHT: 216 kg

3 YEAR WARRANTY
(3 YEAR PARTS 1 YEAR LABOUR)



Stainless steel construction – Constant steam in bottom chamber – Single Chamber Model available with large access door with hinges - Efficient design with very fast heat up time – Stainless steel blade burner - Italian made gas controls and pilots - Reversible Door Stander.

1 DOOR GAS STEAMER LARGE

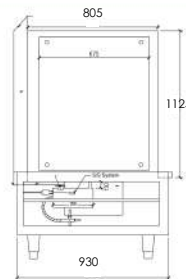
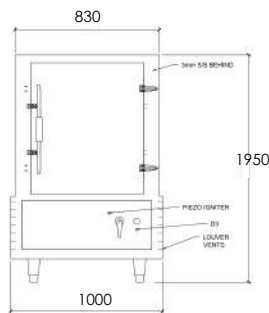

MODEL: FSGL-1

DIMENSIONS: 1000Wx805Dx1950H

OUTPUT: 140 Mj

WEIGHT: 220 kg

3 YEAR WARRANTY
(3 YEAR PARTS 1 YEAR LABOUR)



Stainless steel construction – Constant steam in bottom chamber – Efficient design with very fast heat up time – Stainless steel blade burner - Italian made gas controls and pilots - Easy to service - Readily available spare parts - Reversible Door Stander.

3 DOOR GAS STEAMER SMALL

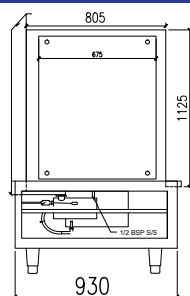
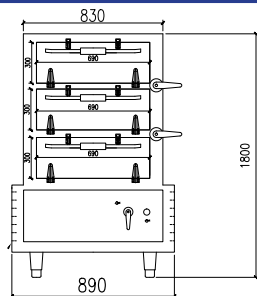

MODEL: FSGS-3

DIMENSIONS: 890Wx950Dx1810H approx

OUTPUT: 140 Mj

WEIGHT: 220 Kg

3 YEAR WARRANTY
(3 YEAR PARTS 1 YEAR LABOUR)



Stainless steel construction – Constant steam in bottom chamber – two chamber can be isolated by ball valves – Efficient design with very fast heat up time – Stainless steel blade burner - Italian made gas controls and pilots - FSGS-Rack Included.

3 DOOR GAS STEAMER LARGE

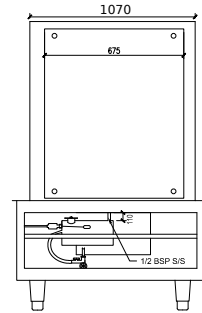
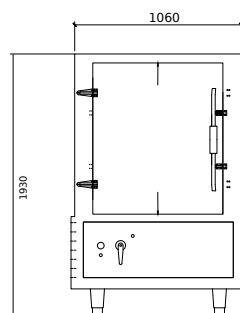

MODEL: FSGL-3

DIMENSIONS: 1060Wx1070Dx1930H

OUTPUT: 140 Mj

WEIGHT: 250 kg

3 YEAR WARRANTY
(3 YEAR PARTS 1 YEAR LABOUR)

- Stainless steel construction – Constant steam in bottom chamber – two chamber can be isolated by ball valves – Efficient design with very fast heat up time – Stainless steel blade burner - Italian made gas controls and pilots - FSGL-Rack Included.

ELECTRIC STEAMER SMALL

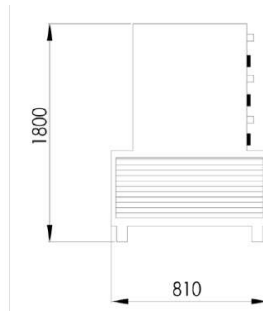
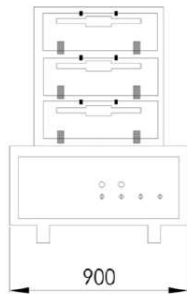

MODEL: 3DFS-810

DIMENSIONS: 900Wx810Dx800H

OUTPUT: 18kw

WEIGHT: 250 kg

3 YEAR WARRANTY
(3 YEAR PARTS 1 YEAR LABOUR)



- Three steam chambers - Full Stainless steel construction- constant steam in bottom chamber
- Two chamber can be isolated by ball valve - three phase power, 25amps.

ELECTRIC STEAMER LARGE

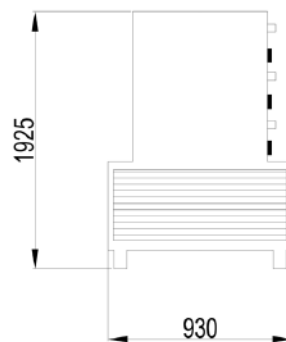
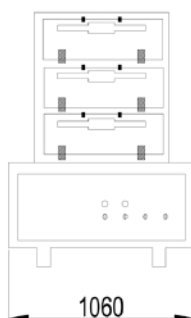

MODEL: 3DFS930

DIMENSIONS: 1060Wx930Dx1925H

OUTPUT: 18kw

WEIGHT: 250 Kg

3 YEAR WARRANTY
(3 YEAR PARTS 1 YEAR LABOUR)



- Three steam chambers - Full Stainless steel construction- constant steam in bottom chamber
- Two chamber can be isolated by ball valve - three phase power, 25amps.

STEAMER ACCESSORIES



- For One Door Gas steamer Small -
- Full Stainless steel construction-
- Wheels for easy unloading

MODEL: FSGS-RACK

DIMENSIONS: 660Wx600Dx850H

WEIGHT: 21 Kg



- For One Door Gas steamer Large -
- Full Stainless steel construction-
- Wheels for easy unloading

MODEL: FSGL-RACK

DIMENSIONS: 770Wx700Dx990H

WEIGHT: 27 Kg



- Used for One Door Gas steamer Small & Large
- Full Stainless steel construction-
- Water drain hole for easy maintenance
- On castors

MODEL: FSG-TROLLEY

DIMENSIONS: 790Wx740Dx850H

WEIGHT: 18 Kg

STEAMER 800

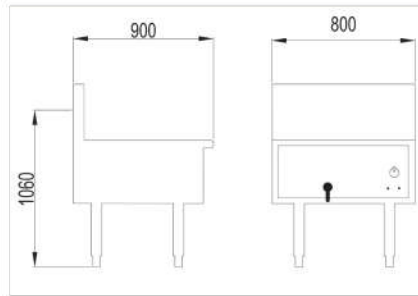

MODEL: STEAMER800

DIMENSIONS: 800Wx900Dx1260H

OUTPUT: 90Mj/hr

WEIGHT: 120 kg

3 YEAR WARRANTY
(3 YEAR PARTS 1 YEAR LABOUR)



- Water auto-refill mechanism - Laundry arm water access via front controls - Optional steaming ring set and cover - 1.00mm Injector Size/1.0Kpa Gas Pressure/90Mj/hr

STEAMER 800 WITH STEAMER RING SET AND COVER

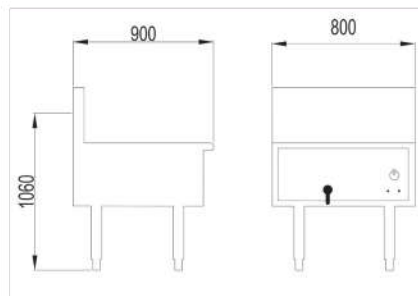

MODEL: STEAMER800 WITH RINGS

DIMENSIONS: 800Wx900Dx1260H

OUTPUT: 90Mj/hr

WEIGHT: 120 kg

3 YEAR WARRANTY
(3 YEAR PARTS 1 YEAR LABOUR)



- Water auto-refill mechanism - Laundry arm water access via front controls 1.00mm Injector Size/1.0Kpa Gas Pressure/90Mj/hr

ROTARY GAS OVEN STEEL BASE

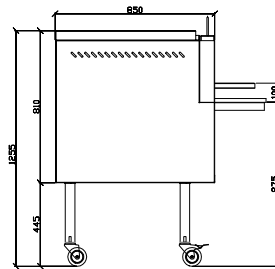
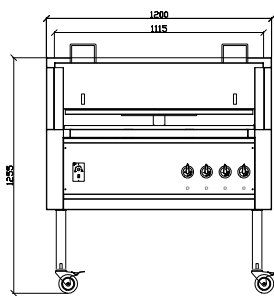
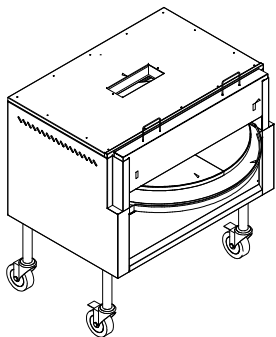

MODEL: RO-1200-ST

DIMENSIONS: 1200Wx850Dx1255H

OUTPUT: High output MJ

WEIGHT: 350 kg

3 YEAR WARRANTY
(3 YEAR PARTS 1 YEAR LABOUR)

Rotating gas oven, 4 burners, variable speed rotating plate, steel plate, adjustable door, on castors

ROTARY GAS OVEN STONE BASE

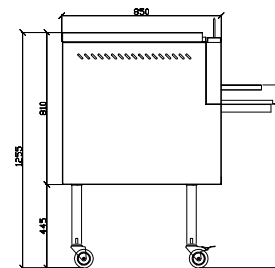
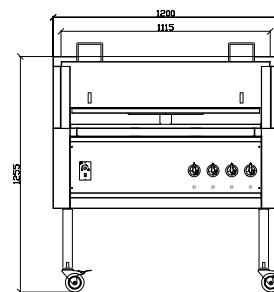
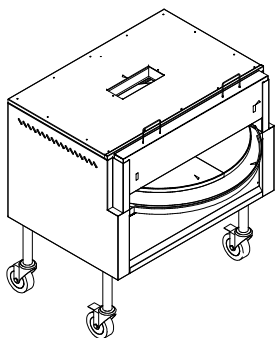

MODEL: RO-1200-RS

DIMENSIONS: 1200Wx850Dx1255H

OUTPUT: High output MJ

WEIGHT: 400 Kg

3 YEAR WARRANTY
(3 YEAR PARTS 1 YEAR LABOUR)

Rotating gas oven, 4 burners, variable speed rotating plate, refractory stone plate, adjustable door, on castors



Please refer to the Spare Parts and Accessories booklet to see all the available optional extras. "Product,, dimensions are given in mm and are approximate. Pictures are for illustrative purposes only. Given information may change without notice. For further information on any line drawings or missing product information, please call our head office on 03 9551 3034. All prices exclude GST. Freight charges apply.

3 BURNER GRIDDLE PLATE WITH TOASTER UNDERNEATH

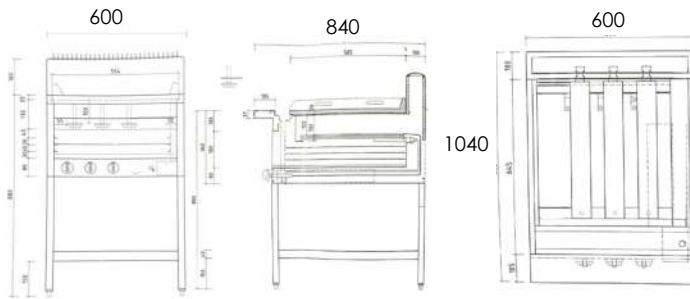

MODEL: GT600

DIMENSIONS: 600Wx840Dx1040H

OUTPUT: 57Mj/hr(NG)/53.4Mj/hr(LPG)

WEIGHT: 121 kg

3 YEAR WARRANTY
(3 YEAR PARTS 1 YEAR LABOUR)



Stainless steel construction with versatile toaster hot plate under - Minimal spacing for the burner providing extreme heat distribution - Available in natural gas and LPG.

5 BURNER GRIDDLE PLATE WITH TOASTER UNDERNEATH

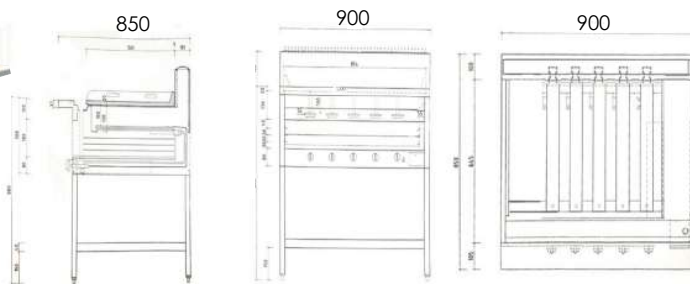

MODEL: GT900

DIMENSIONS: 900Wx850Dx1040H

OUTPUT: 95Mj/hr(NG)/89Mj/hr(LPG)

WEIGHT: 210 kg

3 YEAR WARRANTY
(3 YEAR PARTS 1 YEAR LABOUR)



Stainless steel construction with versatile toaster hot plate under - Minimal spacing for the burner providing extreme heat distribution - Available in natural gas and LPG.

7 BURNER GRIDDLE PLATE WITH TOASTER UNDERNEATH

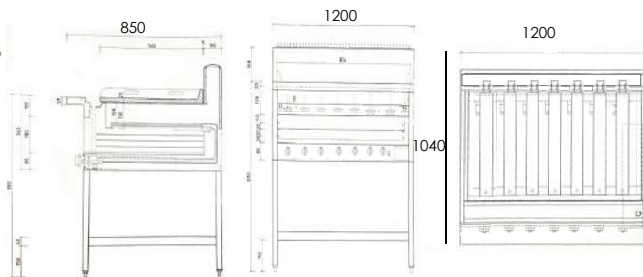

MODEL: GT1200

DIMENSIONS: 1200Wx850Dx1040H

OUTPUT: 133Mj/hr(NG)/124.6Mj/hr(LPG)

WEIGHT: 290 kg

3 YEAR WARRANTY
(3 YEAR PARTS 1 YEAR LABOUR)



Stainless steel construction with versatile toaster hot plate under - Minimal spacing for the burner providing extreme heat distribution - Available in natural gas and LPG.

QUALITY COMPONENTS !



INCLINED ONE HOLE WATERLESS WOK - DUCKBILL BURNER

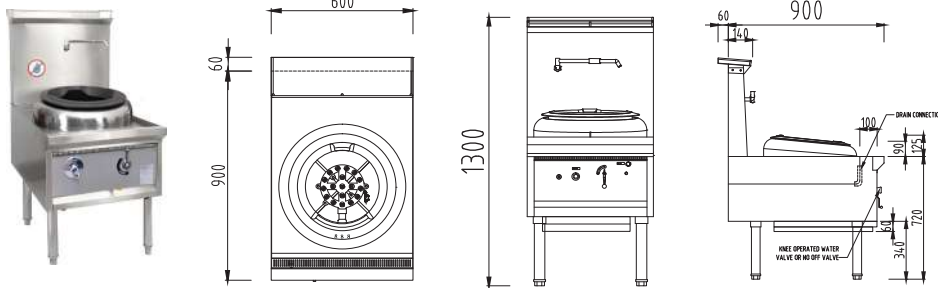

MODEL: 1B DB WL

DIMENSIONS: 600Wx900Dx1300H

OUTPUT: 100(NG)/73(LPG)

WEIGHT: 102 kg

3 YEAR WARRANTY
(3 YEAR PARTS 1 YEAR LABOUR)



- Stainless steel design - Heavy duty frame - Duckbill burner: 18 jets - High powered and even flame
- Fully adjustable flame for maximum temperature control - Available in Natural Gas or Propane - Integrated food catcher and drainer - Energy efficient design - Easy to transport: removable legs, rings splashback and shelf - Italian made gas controls and pilots - Easy to service - Readily available spare parts - Services: Water: Inlet: 12mm (1/2" BSP) Outlet: 40mm (1-1/2" BSP); Gas: 3/4"

INCLINED ONE HOLE WATERLESS WOK - CHIMNEY BURNER

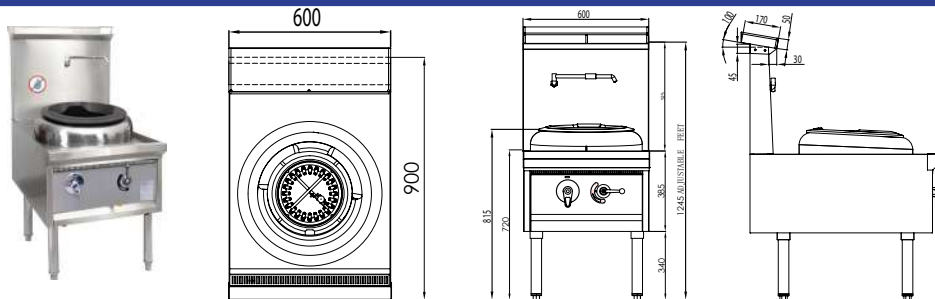

MODEL: 1B CH WL

DIMENSIONS: 600Wx900Dx1300H

OUTPUT: 108(NG)/120(LPG)

WEIGHT: 102 kg

3 YEAR WARRANTY
(3 YEAR PARTS 1 YEAR LABOUR)



- Stainless steel design - Heavy duty frame - Chimney burner: 24 jets - High powered and even flame
- Available in Natural Gas or Propane - Integrated food catcher and drainer - Energy efficient design
- Easy to transport: removable legs, rings, splashback and shelf - Italian made gas controls and pilots
- Easy to service - Readily available spare parts - Services: Water: Inlet: 12mm (1/2" BSP) Outlet: 40mm (1-1/2" BSP); Gas: 3/4"

HORIZONTAL ONE HOLE WATERLESS WOK - DUCKBILL BURNER

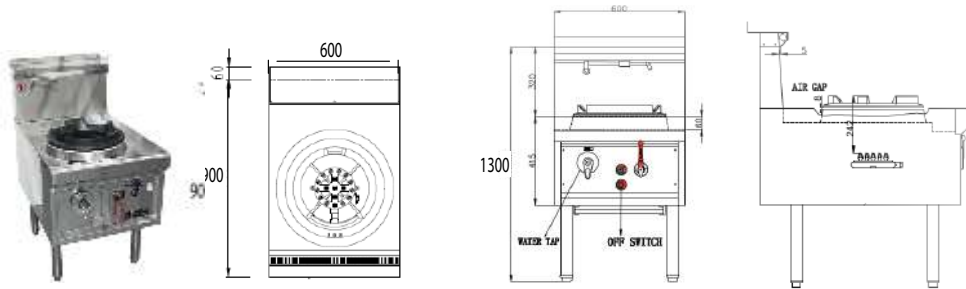

MODEL: F1B DB WL

DIMENSIONS: 600Wx900Dx1300H

OUTPUT: 100MJ/hr(NG)/73MJ/hr(LPG)

WEIGHT: 102 kg

3 YEAR WARRANTY
(3 YEAR PARTS 1 YEAR LABOUR)



- Stainless steel design - Heavy duty frame - Duckbill burner: 18 jets - High powered and even flame
- Fully adjustable flame for maximum temperature control - Available in Natural Gas or Propane - Integrated food catcher and drainer - Energy efficient design - Easy to transport: removable legs, rings, splashback and shelf - Italian made gas controls and pilots - Easy to service - Readily available spare parts - Services: Water: Inlet: 12mm (1/2" BSP) Outlet: 40mm (1-1/2" BSP); Gas: 3/4"

HORIZONTAL ONE HOLE WATERLESS WOK - CHIMNEY BURNER

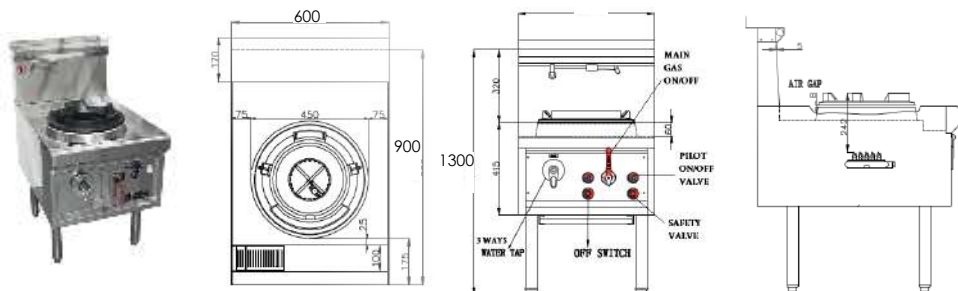

MODEL: F1B CH WL

DIMENSIONS: 600Wx900Dx1300H

OUTPUT: 108MJ/hr(NG)/120MJ/hr(LPG)

WEIGHT: 102 kg

3 YEAR WARRANTY
(3 YEAR PARTS 1 YEAR LABOUR)



- Stainless steel design - Heavy duty frame - Chimney burner 24 jets - High powered and even flame
- Available in Natural Gas or Propane - Integrated food catcher and drainer - Energy efficient design
- Easy to transport: rings, splashback and shelf - Italian made gas controls and pilots - Easy to service - Readily available spare parts - Services: Water: Inlet: 12mm (1/2" BSP) Outlet: 40mm (1-1/2" BSP); Gas: 3/4"

INCLINED TWO HOLE WATERLESS WOK - CHIMNEY BURNER

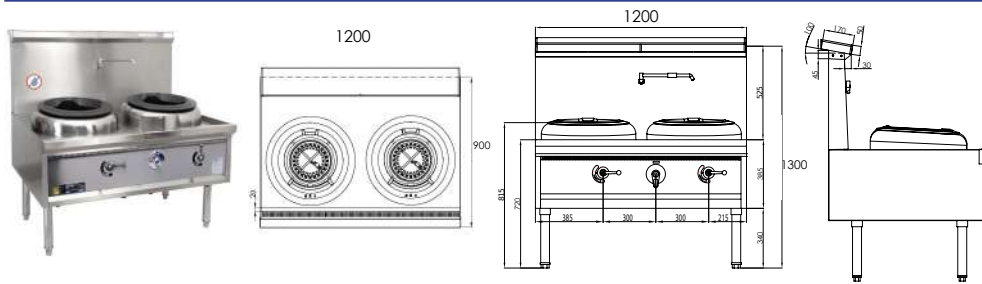

MODEL: 2B CH WL

DIMENSIONS: 1200Wx900Dx1300H

OUTPUT: 216(NG)/240(LPG)

WEIGHT: 176 kg

3 YEAR WARRANTY
(3 YEAR PARTS 1 YEAR LABOUR)



- Stainless steel design - Heavy duty frame - Chimney burner: 24 jets - High powered and even flame
 - Available in Natural Gas or Propane - Integrated food catcher and drainer - Energy efficient design
 - Easy to transport: removable legs, rings, splashback and shelf - Italian made gas controls and pilots - Easy to service - Readily available spare parts - Combination of burners available - Services: Water: Inlet: 12mm (1/2" BSP) Outlet: 40mm (1-1/2" BSP); Gas: 3/4"

HORIZONTAL TWO HOLE WATERLESS WOK - CHIMNEY BURNER

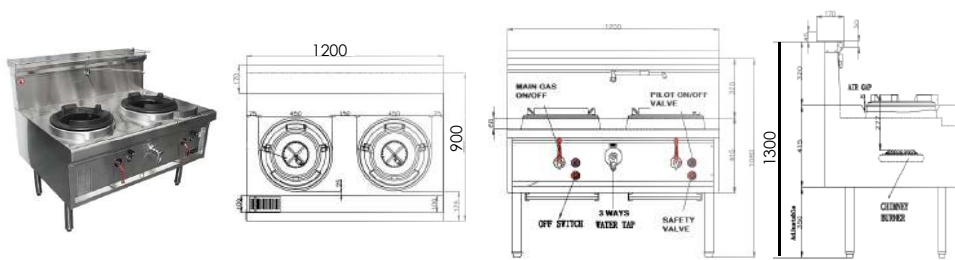

MODEL: F2B CH WL

DIMENSIONS: 1200Wx900Dx1300H

OUTPUT: 216MJ/hr(NG)/240MJ/hr(LPG)

WEIGHT: 176 kg

3 YEAR WARRANTY
(3 YEAR PARTS 1 YEAR LABOUR)



- Stainless steel design-Heavy duty frame - Chimney burner 24 jets - High powered and even flame
 - Available in Natural Gas or Propane - Integrated food catcher and drainer - Energy efficient design - Easy to transport: rings, splashback and shelf - Italian made gas controls and pilots - Easy to service - Readily available spare parts - Services: Water: Inlet: 12mm (1/2" BSP) Outlet: 40mm (1-1/2" BSP); Gas: 3/4"

HORIZONTAL TWO HOLE CHIMNEY WATERLESS WOK WITH TWO SIDE BURNERS

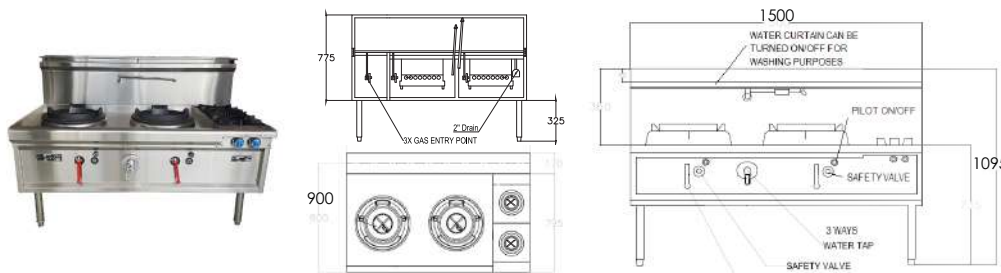

MODEL: F2B CH WL 2B

DIMENSIONS: 1500Wx900Dx1095H

OUTPUT: 274MJ/hr(NG)/292MJ/hr(LPG)

WEIGHT: 195 kg

3 YEAR WARRANTY
(3 YEAR PARTS 1 YEAR LABOUR)



- Horizontal Burner -Stainless steel design - Heavy duty frame - Chimney burner 24 jets - High powered and even flame - Available in Natural Gas or Propane - Integrated food catcher and drainer - Energy efficient design
 - Includes 2 side burners for versatile cooking on right hand side. Easy to transport: rings, splashback and shelf - Italian made gas controls and pilots - Easy to service - Readily available spare parts - Services: Water: Inlet: 12mm (1/2" BSP) Outlet: 40mm (1-1/2" BSP); Gas: 3/4"

INCLINED THREE HOLE WATERLESS WOK - CHIMNEY BURNER

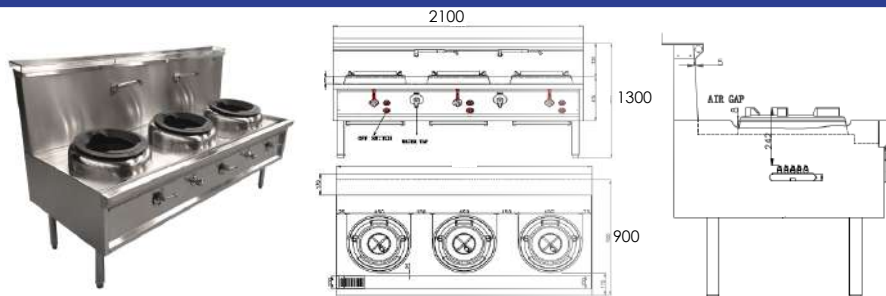

MODEL: 3B CH WL

DIMENSIONS: 2100Wx900Dx1300H

OUTPUT: 280MJ/hr(NG)/310MJ/hr(LPG)

WEIGHT: 256 kg

3 YEAR WARRANTY
(3 YEAR PARTS 1 YEAR LABOUR)



- Stainless steel design - Heavy duty frame - Chimney burner: 24 jets - High powered and even flame
 - Available in Natural Gas or Propane - Integrated food catcher and drainer - Energy efficient design - Easy to transport: removable legs, rings, splashback and shelf - Italian made gas controls and pilots - Easy to service - Readily available spare parts - Combination of burners available - Services: Water: Inlet: 12mm (1/2" BSP) Outlet: 40mm (1-1/2" BSP); Gas: 3/4"

HORIZONTAL THREE HOLE WATERLESS WOK - CHIMNEY BURNER

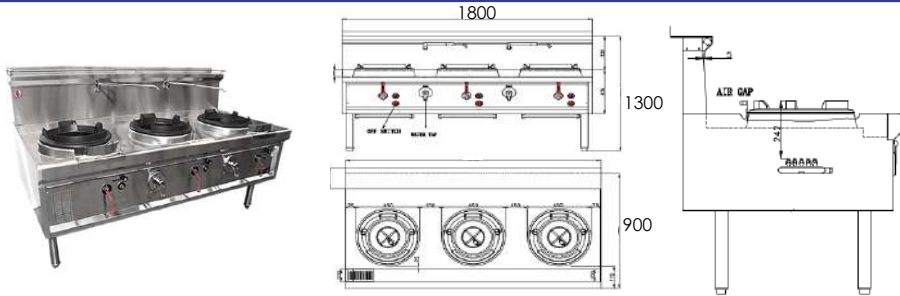

MODEL: F3B CH WL

DIMENSIONS: 1800Wx900Dx1300H

OUTPUT: 316MJ/hr(NG)/313MJ/hr(LPG)

WEIGHT: 256 kg

3 YEAR WARRANTY
(3 YEAR PARTS 1 YEAR LABOUR)



- Stainless steel design - Heavy duty frame - 2 x Chimney burner 24 jets and 1 x Duckbill burner 18 jets High powered and even flame-Available in Natural Gas or Propane - Integrated food catcher and drainer - Energy efficient design Easy to transport: rings, splashback and shelf - Italian made gas controls and pilots - Easy to service - Readily available spare parts - Services: Water: Inlet: 12mm (1/2" BSP) Outlet: 40mm (1-1/2" BSP); Gas: 3/4"



Did you know?

You can select your burner configuration to suit your kitchen needs. For example,

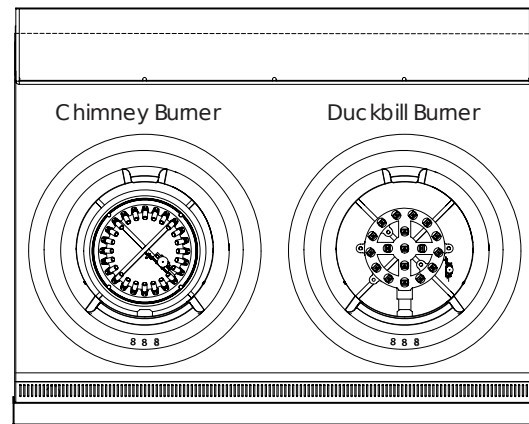

To request your burner configuration, simply specify your requirements when placing your order. For more information, please contact your area sales manager or the head office on (03) 9551 3034

- DUCKBILL IS AVAILABLE UPON REQUEST BUT IS NOT NECESSARILY REQUIRED
- THE FLAME FOR CHIMNEY BURNER CAN BE ADJUSTED TO LOWER SETTING WITHOUT THE NEED TO SWITCH TO DUCKBILL
- WATER CURTAIN CAN BE SELECTED BEHIND SHELVES OR OUT OF LAUNDRY TYPE SPOUT OR BOTH
- WATER TO COOL DOWN WOK IS NOT ESSENTIAL BUT CAN BE TURNED ON IF DESIRED

INCLINED ONE HOLE WATERLESS SUPERWOK - CHIMNEY BURNER

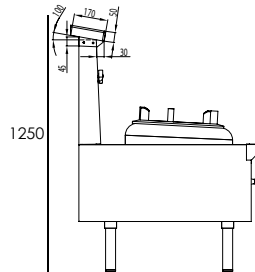
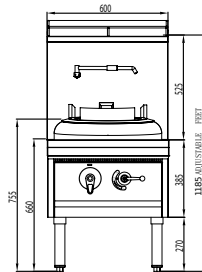
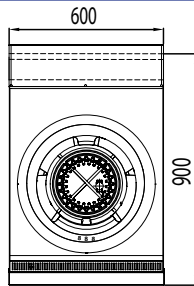

MODEL: 1B CH WL SW

DIMENSIONS: 600Wx900Dx1250H

OUTPUT: 155MJ/hr(NG)/140MJ/hr(LPG)

WEIGHT: 105 kg

3 YEAR WARRANTY
(3 YEAR PARTS 1 YEAR LABOUR)



- Stainless steel design - Heavy duty frame - Super Chimney burner: 48 jets (Natural Gas)/36 jets (Propane) - High powered and even flame - Available in Natural Gas or Propane - Integrated food catcher and drainer - Energy efficient design - Easy to transport: removable legs, rings, splashback and shelf - Italian made gas controls and pilots - Easy to service - Readily available spare parts- Services: Water: Inlet: 12mm (1/2" BSP) Outlet: 40mm (1-1/2" BSP); Gas: 3/4"

INCLINED TWO HOLE WATERLESS SUPERWOK - CHIMNEY BURNER

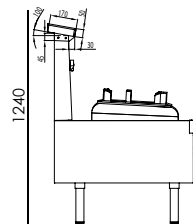
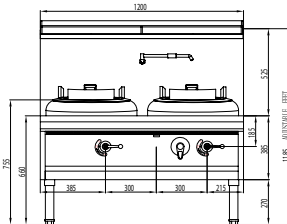
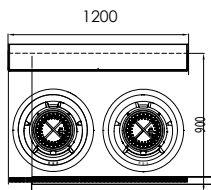

MODEL: 2B CH WL SW

DIMENSIONS: 1200Wx900Dx1240H

OUTPUT: 310MJ/hr(NG)/280MJ/hr(LPG)

WEIGHT: 196 kg

3 YEAR WARRANTY
(3 YEAR PARTS 1 YEAR LABOUR)



- Stainless steel design - Heavy duty frame - Super Chimney burner: 48 jets (Natural Gas)/36 jets (Propane) - High powered and even flame - Available in Natural Gas or Propane - Integrated food catcher and drainer - Energy efficient design - Easy to transport: removable legs, rings, splashback and shelf - Italian made gas controls and pilots - Easy to service - Readily available spare parts- Services: Water: Inlet: 12mm (1/2" BSP) Outlet: 40mm (1-1/2" BSP); Gas: 3/4"

INCLINED THREE HOLE WATERLESS SUPERWOK - CHIMNEY BURNER

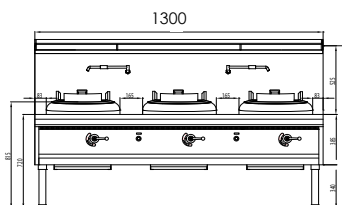
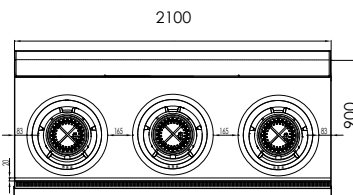

MODEL: 3B CH WL SW

DIMENSIONS: 2100Wx900Dx1300H

OUTPUT: 465MJ/hr(NG)/420MJ/hr(LPG)

WEIGHT: 300 kg

3 YEAR WARRANTY
(3 YEAR PARTS 1 YEAR LABOUR)



- Stainless steel design - Heavy duty frame - Super Chimney burner: 48 jets (Natural Gas)/36 jets (Propane) - High powered and even flame - Available in Natural Gas or Propane - Integrated food catcher and drainer - Energy efficient design - Easy to transport: removable legs, rings, splashback and shelf - Italian made gas controls and pilots - Easy to service - Readily available spare parts- Services: Water: Inlet: 12mm (1/2" BSP) Outlet: 40mm (1-1/2" BSP); Gas: 3/4"

SINGLE HOLE WATERLESS TURBO JET WOK

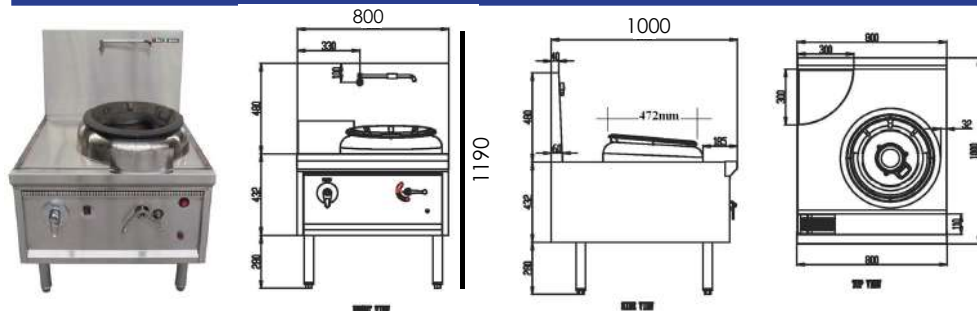

MODEL: TJ-1

DIMENSIONS: 800Wx1000Dx1190H

OUTPUT: 155MJ/hr(NG)/155MJ/hr(LPG)

WEIGHT: 120 kg

3 YEAR WARRANTY
(3 YEAR PARTS 1 YEAR LABOUR)



-Stainless steel design - Heavy duty frame - High powered and even flame - Fully adjustable flame for maximum temperature control - Available in Natural Gas only - Integrated food catcher and drainer - Energy efficient design - Easy to transport: removable legs, rings, splashback and shelf - Italian made gas controls and pilots - Easy to service - Readily available spare parts- **Services:** Water: Inlet: 12mm (1/2" BSP) Outlet: 40mm (1-1/2" BSP); Gas: 3/4"

SINGLE HOLE MAXI WOK

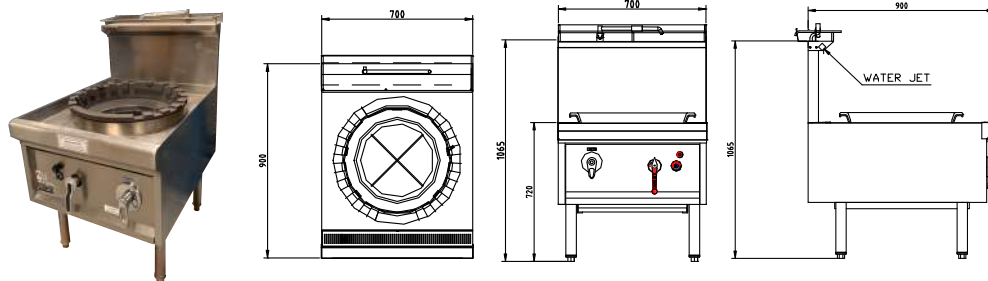

MODEL: M1B DB WL

DIMENSIONS: 700Wx900Dx1050H

OUTPUT: 144MJ/h

WEIGHT: 101 kg

3 YEAR WARRANTY
(3 YEAR PARTS 1 YEAR LABOUR)



Stainless steel design – Heavy duty frame – Duck bill burner – High powered and even flame – Available in Natural gas – Integrated food catcher and drainer – Energy efficient –Services : water inlet :12mm (1/2" BSP) Outlet 32 mm (1 1/4" BSP) water is not required for deck cooling water is for cleaning only : Gas 20 mm (3/4" BSP) Easy to transport: removable legs, rings, splashback and shelf – Italian made gas controls and pilots – Easy to service – Readily available spare parts

DOUBLE HOLE MAXI WOK

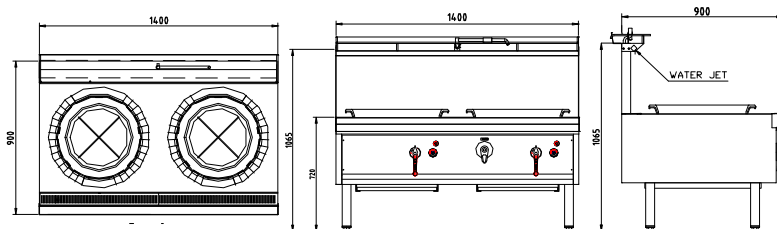

MODEL: M2B DB WL

DIMENSIONS: 1400Wx900Dx1050H

OUTPUT: 288 MJ/h

WEIGHT:210 kg

3 YEAR WARRANTY
(3 YEAR PARTS 1 YEAR LABOUR)



Stainless steel design – Heavy duty frame – Duck bill burner – High powered and even flame – Available in Natural gas – Integrated food catcher and drainer – Energy efficient –Services : water inlet :12mm (1/2" BSP) Outlet 32 mm (1 1/4" BSP) water is not required for deck cooling water is for cleaning only : Gas 20 mm (3/4" BSP) Easy to transport: removable legs, rings, splashback and shelf – Italian made gas controls and pilots – Easy to service – Readily available spare parts

THREE HOLE MAXI WOK

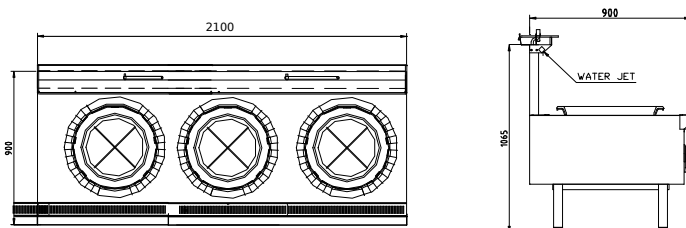

MODEL: M3B DB WL

DIMENSIONS: 2100Wx900Dx1050H

OUTPUT: 432 MJ/h

WEIGHT: 310 kg

3 YEAR WARRANTY
(3 YEAR PARTS 1 YEAR LABOUR)



Stainless steel design – Heavy duty frame – Duck bill burner 28 jet – High powered and even flame – Available in Natural gas – Integrated food catcher and drainer – Energy efficient –Services : water inlet :12mm (1/2" BSP) Outlet 32 mm (1 1/4" BSP) water is not required for deck cooling water is for cleaning only : Gas 20 mm (3/4" BSP) Easy to transport: removable legs, rings, splashback and shelf – Italian made gas controls and pilots – Easy to service – Readily available spare parts.

ONE HOLE COMPACT WOK BURNER

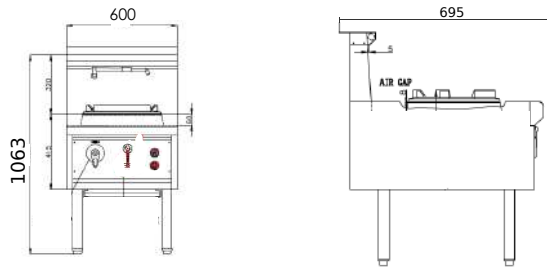

MODEL: C1B CH WL

DIMENSIONS: 600Wx695Dx1063H

OUTPUT: (NG108 Mj/h) & (LGP 120Mj/h)

WEIGHT: 102 kg

3 YEAR WARRANTY
(3 YEAR PARTS 1 YEAR LABOUR)



1 point battery igniter c/w switch or piezo igniter,- A spillage tray is provided for each wok unit.
- Flame failure control – . A knee operated or manual on/off water valve is located on the control panel, or manually operated water valve

Services: Water: Inlet:12mm (1/2" BSP) Outlet: 40mm (1-1/2" BSP); Gas: 3/4"

TWO HOLE COMPACT WOK BURNER

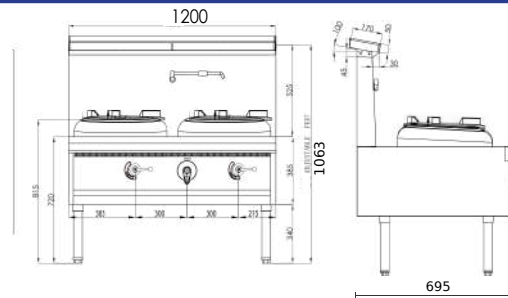

MODEL: C2B CH WL

DIMENSIONS: 1200Wx695Dx1063H

OUTPUT: (NG108 Mj/h) & (LGP 120Mj/h)

WEIGHT: 166 kg

3 YEAR WARRANTY
(3 YEAR PARTS 1 YEAR LABOUR)



1 point battery igniter c/w switch or piezo igniter,- A spillage tray is provided for each wok unit.
- Flame failure control – . A knee operated or manual on/off water valve is located on the control panel, or manually operated water valve

Services: Water: Inlet:12mm (1/2" BSP) Outlet: 40mm (1-1/2" BSP); Gas: 3/4"

THREE HOLE COMPACT WOK BURNER

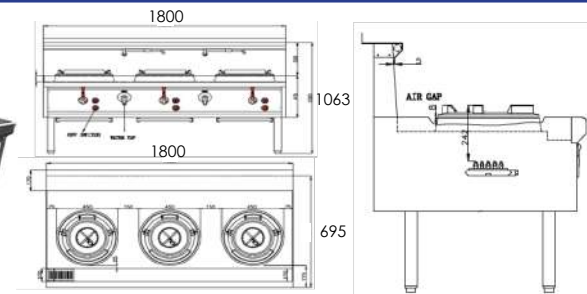

MODEL: C3B CH WL

DIMENSIONS: 1800Wx695Dx1063H

OUTPUT: (NG108 Mj/h) & (LGP 120Mj/h)

WEIGHT: 246 kg

3 YEAR WARRANTY
(3 YEAR PARTS 1 YEAR LABOUR)



1 point battery igniter c/w switch or piezo igniter,- A spillage tray is provided for each wok unit.
- Flame failure control – . A knee operated or manual on/off water valve is located on the control panel, or manually operated water valve

Services: Water: Inlet:12mm (1/2" BSP) Outlet: 40mm (1-1/2" BSP); Gas: 3/4"

ONE HOLE WATERLESS STOCKPOT BURNER - DUCKBILL BURNER

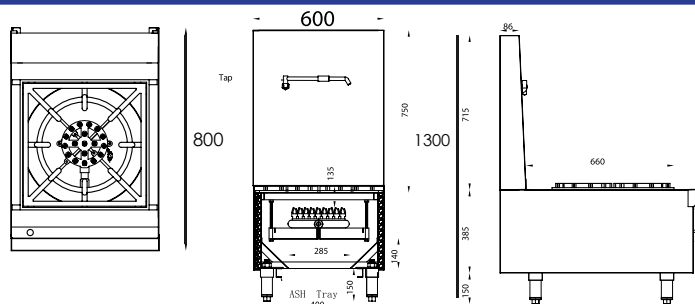

MODEL: 1LOWDB

DIMENSIONS: 600Wx800DX1300H

OUTPUT: (NG100 Mj/h) & (LGP 100Mj/h)

WEIGHT: 90 kg

3 YEAR WARRANTY
(3 YEAR PARTS 1 YEAR LABOUR)



- Stainless steel design - Heavy duty frame - Duckbill burner: 18 jets - High powered and even flame - Fully adjustable flame for maximum temperature control - Available in Natural Gas or Propane - Integrated food catcher and drainer - Energy efficient design - Easy to transport: removable legs, rings, splashback and shelf
Italian made gas controls and pilots Easy to service Readily available spare parts

Services: Water: Inlet:12mm (1/2" BSP) Outlet: 40mm (1-1/2" BSP); Gas: 3/4"

WOK ACCESSORIES

- Knee operated tap to suit all Oxford Wok products

MODEL: KNEE OPERATED TAP

WEIGHT: 1kg



- Wok adaptor to suit larger 17" woks. Adaptor ring is **not required** for SuperWok models

MODEL: ADAPTOR RING

WEIGHT: 10 kg



- Chimney burner to suit WOK888 wok burners

MODEL: CHIMNEY BURNER

WEIGHT: 5 kg



- Duckbill burner to suit WOK888 wok burners

MODEL: DUCKBILL BURNER

WEIGHT: 5 kg



- Super Chimney Burner to suit SuperWok

MODEL: SUPER CHIMNEY BURNER

WEIGHT: 5 kg



- Stainless Steel construction
- Pot to suit low Burners
- Includes safe release valve
- 170 Lt capacity

MODEL: SS-POT195

DIMENSIONS: 600Hx610W

CAPACITY: 170 Lt

STEAMER 800 ACCESSORIES



- Wire basket to suit 6BASKET-NC

MODEL: OXFORD WIRE BASKET FOR 6 BASK

DIMENSIONS: Ø150x300H



1 x Stackable ring to suit STEAMER 800

MODEL: ST-RING

DIMENSIONS: Ø510Wx95H



- Cover for stackable rings to suit STEAMER 800

MODEL: ST-COVER

DIMENSIONS: Ø510x105H



- Cheong Fun steamer to suit 6BASKET-NC

MODEL: CHFUN-ST

DIMENSIONS: 450Wx560Dx210D



- 5 tier steamer and cover set to suit STEAMER 800

MODEL: ST-STEAMER 5 TIER SET + COVER

DIMENSIONS: Ø510Wx580H

ROYSTON

COUNTERLINE EQUIPMENT

Induction and Electric Cookers

Vertical Rotisseries/ Kebab Machines

Food Warming

Oil Filters

Benchtopy Fryers

Electric Grills

Toasters

Convection Ovens

Microwaves

Meat Slicers & Minchers

Pizza Dough Rollers

Popcorn Machines

Confectionary Equipment

Milkshake Makers

Ice Making Machines



FREESTANDING INDUCTION WOK

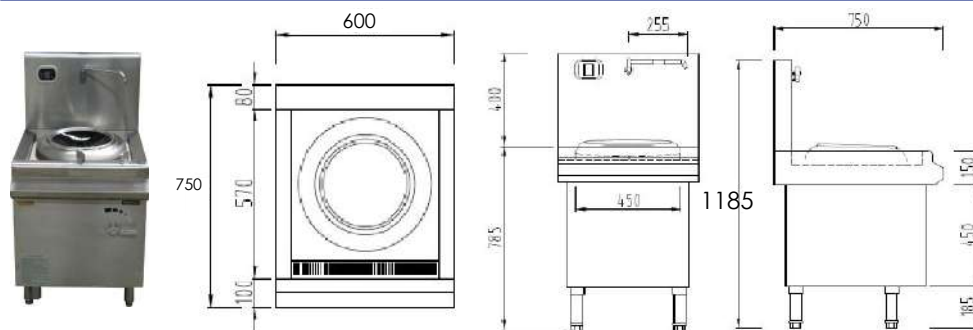

MODEL: DL-5KW
DIMENSIONS: 600Wx750Dx1185H
OUTPUT: 5 KW
WEIGHT: 50 kg

- Easy to operate and clean - Digital display - Stainless steel finish - Adjustable heat level - Removable front tray - 240V 21A



COMMERCIAL INDUCTION COOKER

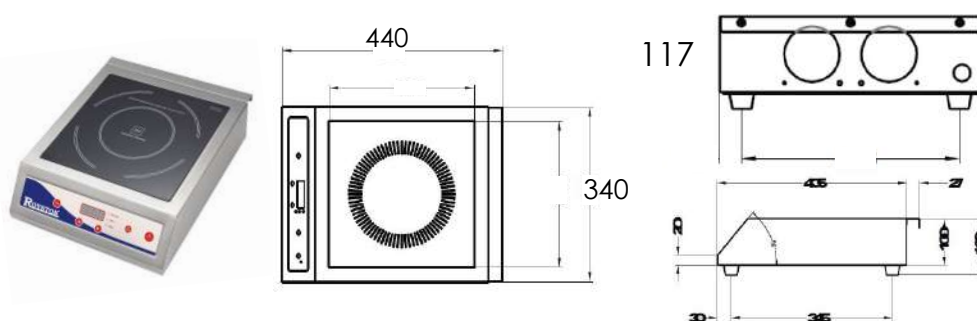

MODEL: CIC3500W
DIMENSIONS: 340Wx440Dx117H
OUTPUT: 3.5KW
WEIGHT: 6.8 kg

- Stainless steel body - German made 'Schott' Glass - Variable power from 500W-3500W - LED display with digital 4 button controls - Temperature range: 60°C to 240°C - Auto turn off when unused for 2 hours - "No pan" protection - Overheating protection - 240V 15A 50Hz



COMMERCIAL INDUCTION COOKER

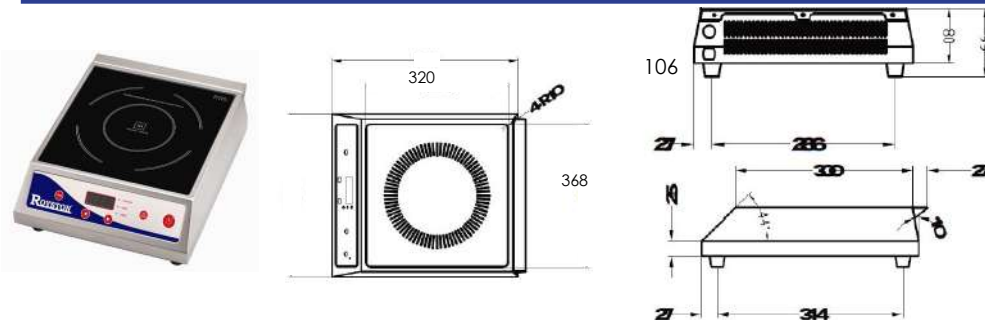

MODEL: CIC2700W
DIMENSIONS: 320Wx368Dx106H
OUTPUT: 2.7KW
WEIGHT: 5.2 kg

- Stainless steel body - German made 'Schott' Glass - Variable power from 500W-2700W - Timer function: 0-180 mins - LED display with digital 4 button controls - Temperature range: 60°C to 240°C - Auto turn off when unused for 2 hours - "No pan" protection - Overheating protection - 240V 15A 50Hz



COMMERCIAL INDUCTION COOKER

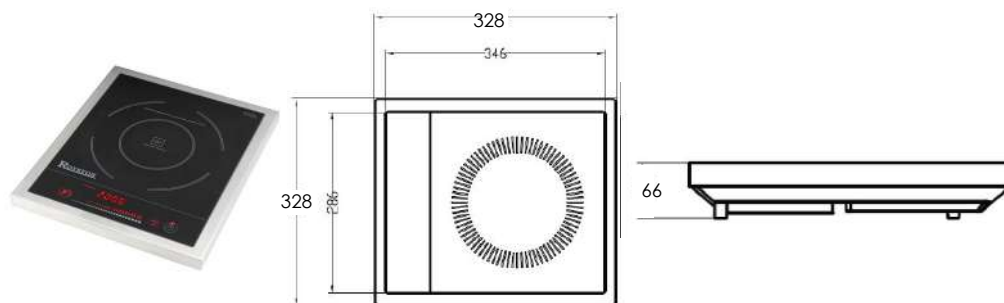

MODEL: CIC2000W
DIMENSIONS: 328Wx383Dx66H
OUTPUT: 2KW
WEIGHT: 3.4 kg

- Stainless steel body - German made 'Schott' Glass - Variable power from 500W-2000W - LED display with digital 4 button controls - Temperature range: 60°C to 240°C - Auto turn off when unused for 2 hours - "No pan" protection - Overheating protection - 240V 10A 50Hz



COMMERCIAL INDUCTION COOKER

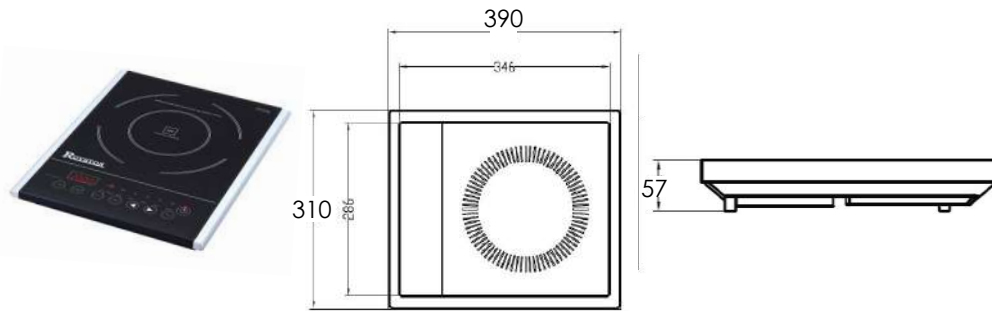

MODEL: IC2000

DIMENSIONS: 310Wx390Dx57H

OUTPUT: 2KW

WEIGHT: 2.5 kg

- Durable ABS plastic: black body with silver accent - Touch sensitive controls - Touch control & safety lock - Timer: 0-180 mins - "Keep Warm" function - German made 'Schott' Glass - Variable power from 500W-2000W - LED display with digital 4 button controls - Temperature range: 60°C to 240°C - Auto turn off when unused for 2 hours - "No pan" protection - Overheating protection - 240V 10A 50Hz



STEAMING AND FRYING DUMPLING MACHINE

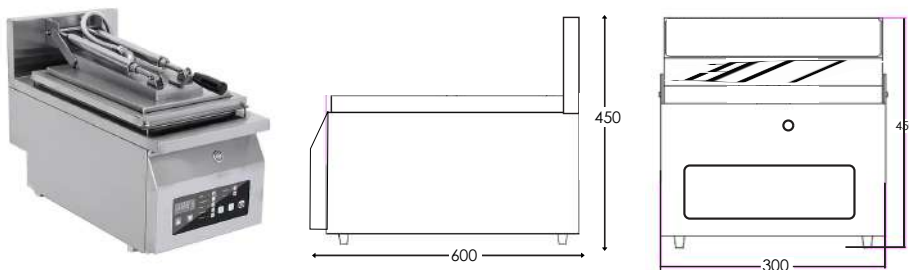

Steaming and frying function, - Perfect for Gyoza and Dumplings

MODEL: DC-06

DIMENSIONS: 300Wx600Dx450H

OUTPUT: 3 Kw

WEIGHT: 30 Kg



DANGER	
ELECTROMAGNETIC INTERFERENCE	
DANGEROUS TO PACEMAKERS	

SAFETY WARNING

Induction cooking relies on oscillating magnetic fields to produce heat. Persons implanted with pacemakers or other electronic implants should exercise caution while using induction cookers. For more information, please contact your local sales representative or our head office: (03) 9551 3034 or sales@concordefe.com.au

4 BURNER INFRARED VERTICAL ROTISSERIE (KEBAB MACHINE)

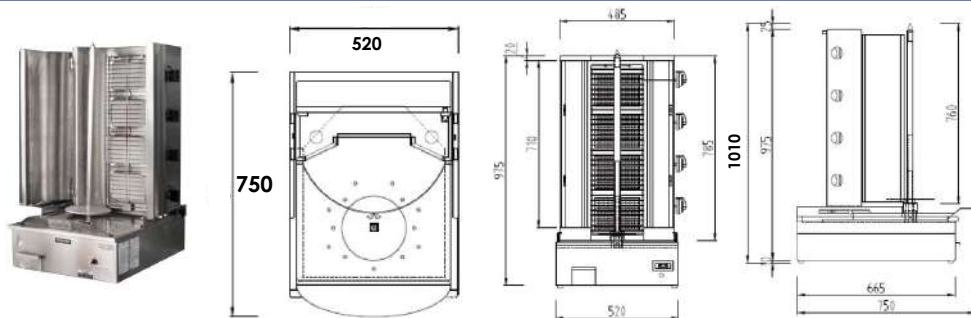

MODEL: 4BIVRDIT

DIMENSIONS: 520Wx750Dx1010H

OUTPUT: 42 Mj/Hr

WEIGHT: 45 kg

3 YEAR WARRANTY
(3 YEAR PARTS 1 YEAR LABOUR)

ROYSTON®

- Flame failure incorporating thermo-electric burner safety cutout - Adjustable straight line radiant burner assembly - Available in Natural Gas or Propane - 240V 10A 50Hz (runs electric motor)

4 BURNER INFRARED VERTICAL ROTISSERIE (SWING MODEL)

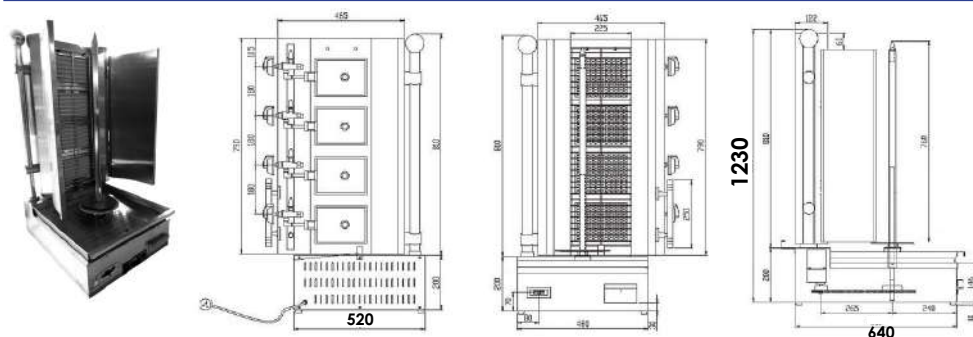

MODEL: 4BIVRDIS

DIMENSIONS: 520Wx640Dx1230H

OUTPUT: 42 Mj/Hr

WEIGHT: 112 kg

3 YEAR WARRANTY
(3 YEAR PARTS 1 YEAR LABOUR)

ROYSTON®

- Swing model - Flame failure incorporating thermo-electric burner safety cutout - Adjustable pivoting radiant burner assembly - Available in Natural Gas or Propane - 240V 10A 50Hz (runs electric motor)

KEBAB MACHINE ACCESSORIES

- Kit includes gas hose, plate wire, clips, 900mm long class D hose, AGA approval number 7854, 1/2 BSP MALE one side and 1/2 BSP NUT & CONE on the other side

MODEL: INSTALLATION KIT

2 MODULE BAIN MARIE - 2 ELEMENTS

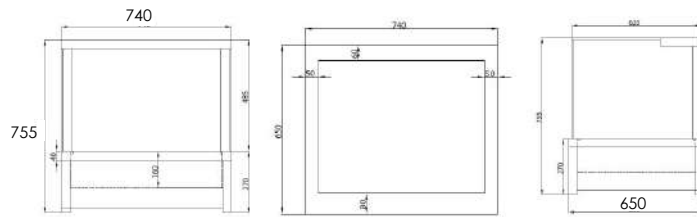

MODEL: BM-2

DIMENSIONS: 740Wx650Dx755H

OUTPUT: 1.5KW

WEIGHT: 50 kg

- Fits 4 x 1/2 GN food pans - Suitable for wet operation only - Double skinned for added insulation
- Food pans not included - 240V 10A 50Hz

ROYSTON®

3 MODULE BAIN MARIE - 3 ELEMENTS

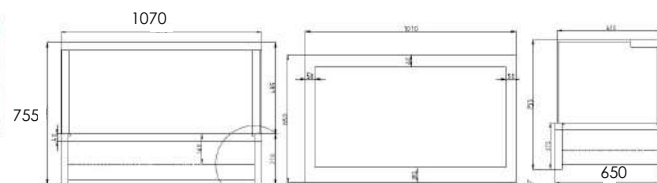

MODEL: BM-3

DIMENSIONS: 1070Wx650Dx755H

OUTPUT: 2.4KW

WEIGHT: 65 kg

- Fits 6 x 1/2 GN food pans - Suitable for wet operation only - Double skinned for added insulation
- Food pans not included - 240V 10A 50Hz

ROYSTON®

4 MODULE BAIN MARIE - 4 ELEMENTS

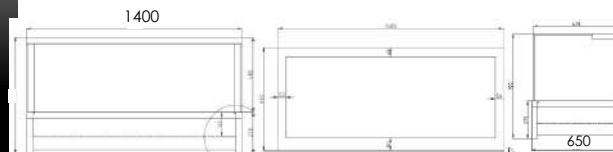

MODEL: BM-4

DIMENSIONS: 1400Wx650Dx755H

OUTPUT: 3.3KW

WEIGHT: 80 kg

- Fits 8 x 1/2 GN food pans - Suitable for wet operation only - Double skinned for added insulation
- Food pans not included - 240V 15A 50Hz

ROYSTON®

5 MODULE BAIN MARIE - 5 ELEMENTS

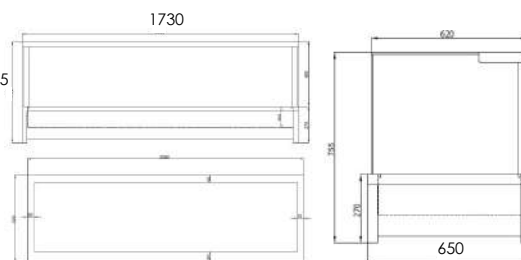

MODEL: BM-5

DIMENSIONS: 1730Wx650Dx755H

OUTPUT: 3KW

WEIGHT: 95 kg

- Fits 10 x 1/2 GN food pans - Suitable for wet operation only - Double skinned for added insulation
- Food pans not included - 240V 15A 50Hz

ROYSTON®

6 MODULE BAIN MARIE - 6 ELEMENTS

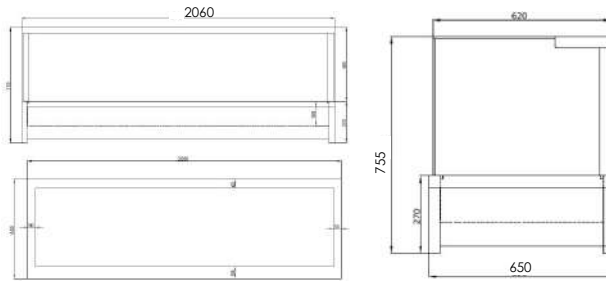

MODEL: BM-6

DIMENSIONS: 2060Wx650Dx755H

OUTPUT: 3.6KW

WEIGHT: 115 kg

ROYSTON®

- Fits 12 x 1/2 GN food pans - Suitable for wet operation only - Double skinned for added insulation - Food pans not included - 240V 15A 50Hz

WIDE RANGE OF FOOD SERVICE PRODUCTS

Concorde

FOOD EQUIPMENT WHOLESALERS



ILLUMINATED PIE WARMER - 50 PIES

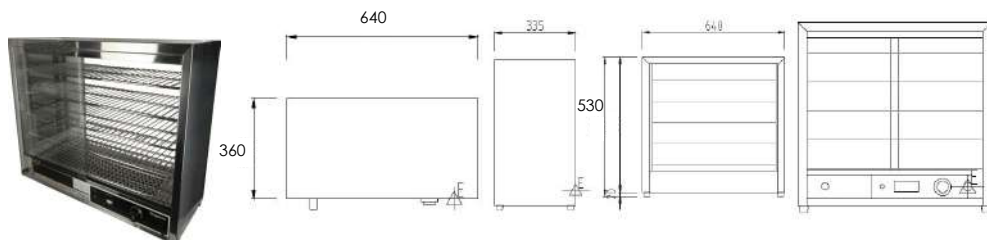

MODEL: PIE-50
DIMENSIONS: 640Wx360Dx530H
OUTPUT: 1KW
WEIGHT: 21 kg

- Temperature range: 30°C - 110°C - Capacity: approximately 50 pies - Heat resistant glass
 - 240V 10A 50Hz



ILLUMINATED PIE WARMER - 100 PIES

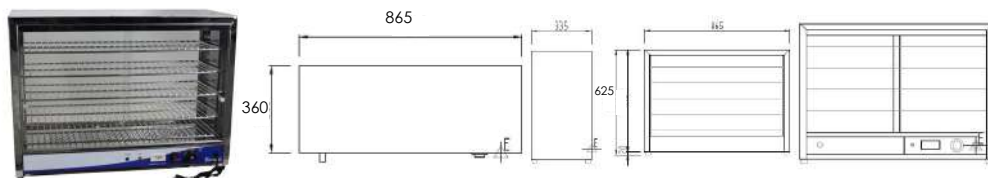

MODEL: PIE-100
DIMENSIONS: 865Wx360Dx625H
OUTPUT: 1.5KW
WEIGHT: 35 kg

- Temperature range: 30°C - 110°C - Capacity: approximately 100 pies - Heat resistant glass
 - 240V 10A 50Hz



ILLUMINATED ANGLED GLASS PIE WARMER - 50 PIES

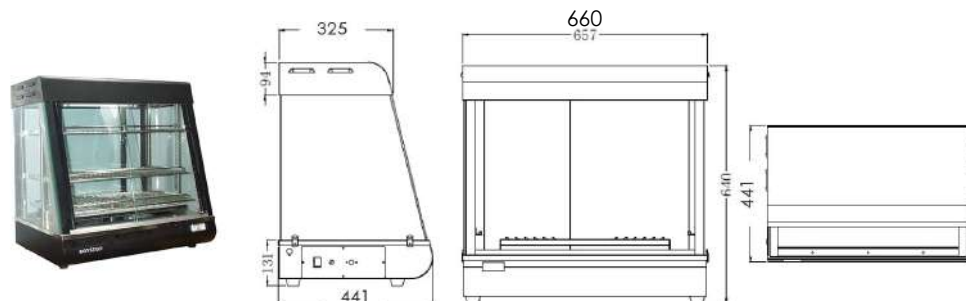

MODEL: PIEANGLE-50
DIMENSIONS: 660Wx437Dx635H
OUTPUT: 1.84KW
WEIGHT: 37 kg

- Heat resistant glass - Three tray display - Internal lights - Humidity tray included - Temperature range: 30°C - 110°C - 240V 10A 50Hz



HEATED FOOD DISPLAY/ PIE WARMER

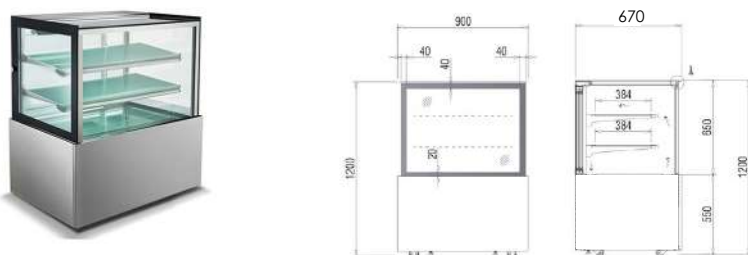

MODEL: PW900
DIMENSIONS: 900Wx670Dx1200H
OUTPUT: 1000W
WEIGHT: 120 kg

900 mm straight glass heated display - 3 shelves + base - Temperature range: 30 C - 80 C
 - 240V 15A 50HZ - Matches the profile of 3 Tier cake displays.



Please refer to the Spare Parts and Accessories booklet to see all the available optional extras. "Product" dimensions are given in mm and are approximate. Pictures are for illustrative purposes only. Given information may change without notice. For further information on any line drawings or missing product information, please call our head office on 03 9551 3034. All prices exclude GST. Freight charges apply.

ILLUMINATED FOOD DISPLAY STEAMER

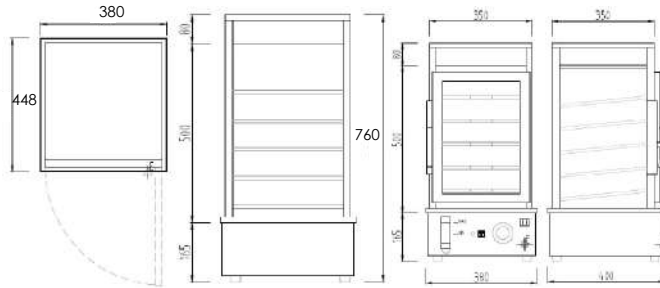

MODEL: DS760
DIMENSIONS: 380Wx448Dx760H
OUTPUT: 1.2kw
WEIGHT: 25 kg

- Full stainless steel construction - Can be used to steam or warm food - Easy to use controls - Heat light indicators - Secure lock handle - Ideal for buns/dim sim etc. - Glass on all 4 sides for maximum display area - Temperature range: 30°C to 110°C - 240V 10A 50Hz



ILLUMINATED FOOD DISPLAY STEAMER

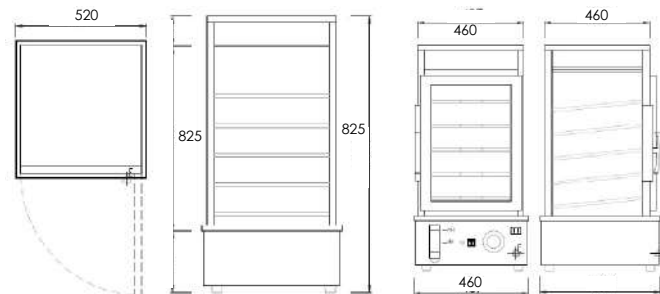

MODEL: DS825
DIMENSIONS: 460Wx520Dx825H
OUTPUT: 1.2KW
WEIGHT: 31kg

- Full stainless steel construction - Can be used to steam or warm food - Easy to use controls - Heat light indicators - Secure lock handle - Ideal for buns/dim sim etc. - Glass on all 4 sides for maximum display area - Temperature range: 30°C to 110°C - 240V 10A 50Hz



CURVED GLASS HEATING CABINET

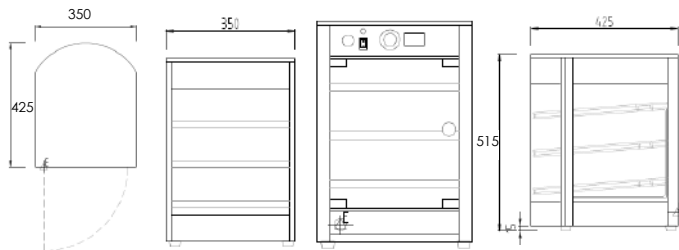

MODEL: HDC-CURVED
DIMENSIONS: 350Wx425Dx515H
OUTPUT: 850W
WEIGHT: 16 kg

- 4 sided glass - 3 tray display - Internal light - Adjustable temperature - Internal light - Temperature range: up to 85°C - 240V 10A 50Hz



10 LITRE SOUP KETTLE

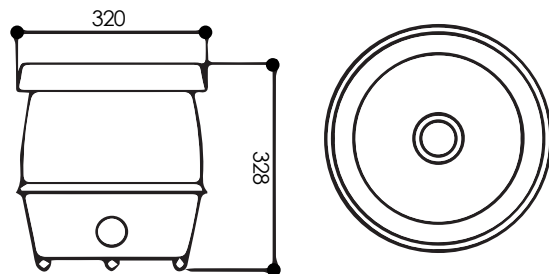

MODEL: SK10LT
DIMENSIONS: ø320Wxx328H
OUTPUT: 4W
WEIGHT: 4.5 kg

- 10 litre capacity - Ladle hole - Easy to clean - Simple controls - Heat resistant outer casing - Temperature range: 30°C to 110°C - 240V 10A 50Hz



PLATE WARMER - SINGLE TUBE

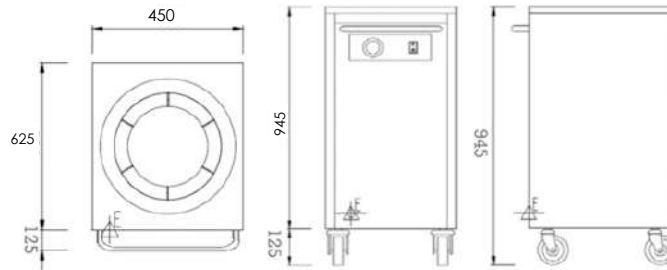

MODEL: PW1

DIMENSIONS: 450Wx625Dx945H

OUTPUT: 0.4KW

WEIGHT: 23 kg

- Single heating tube - On castors - Approximately 75 plate capacity - Adjustable for different plate diameters - Stainless steel construction - Temperature range: 30°C to 85°C - 240V 10A 50Hz

ROYSTON®

PLATE WARMER - DOUBLE TUBE

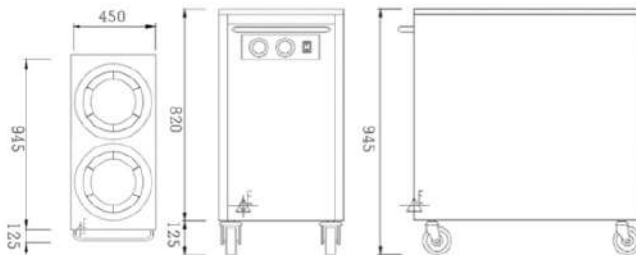

MODEL: PW2

DIMENSIONS: 450Wx1075Dx945H

OUTPUT: 0.8KW

WEIGHT: 38 kg

- Double heating tube - On castors - Approximately 150 plate capacity - Adjustable for different plate diameters - Stainless steel construction - Temperature range: 30°C to 85°C - 240V 10A 50Hz

ROYSTON®



Please Note

If you intend on using the oil filter with solid fats or lard, please contact our head office on (03) 9551 3034 as we can assist you with suitable modifications

CHIP DUMP/WARMER

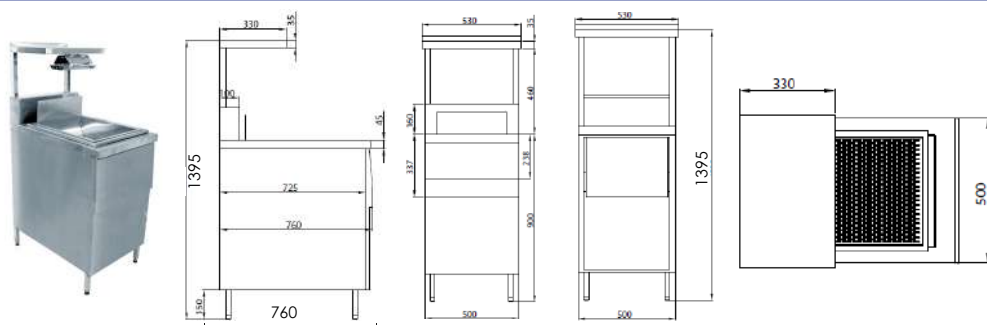

MODEL: CD01

DIMENSIONS: 530Wx760Dx1395H

OUTPUT: 2KW

WEIGHT: 45 kg



- Heating element on the bottom to keep chips warm - Cupboard underneath for storage of Royston® OF28 Oil Filter - Heating lamp above - 240V 10A 50Hz

HEAVY DUTY OIL FILTER

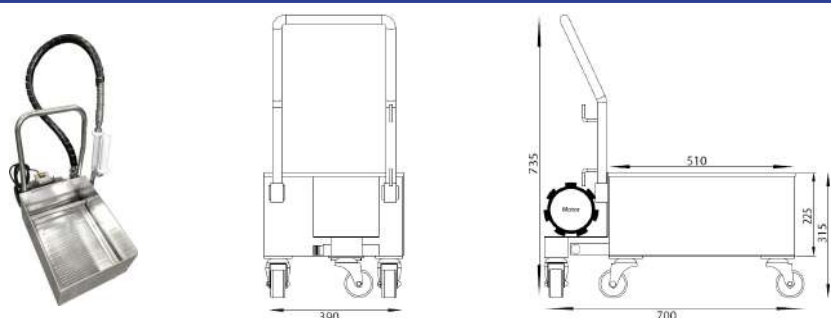

MODEL: OF28

DIMENSIONS: 390Wx700Dx735H

OUTPUT: 619KW

WEIGHT: 43 kg



- 28 litre tank capacity - High volume flow rate: 30-50 litres/min - Powerful motor for fast filtration - Can be stored inside Royston® CD01 & MK2 Chip Dump/Warmers - 240V 10A 50Hz.

OIL FILTER ACCESSORIES



- Royston oil filter paper to suit OF28 Oil filter (100 pack)

MODEL: 890005

DIMENSIONS: 665Wx430D

MAGNESOL®



- Extend the life of your frying oil and cut costs significantly by using Magnesol Ideal for use by any establishment that consumes a lot of oil.

MODEL: MAG18

DIMENSIONS: 190Wx440Dx125H



MAGNESOL® GENERIC 4.8oz 90 pkt



- Extend the life of your frying oil and cut costs significantly by using Magnesol Ideal for use by any establishment that consumes a lot of oil. - Portion control packs

MODEL: MAGPC

DIMENSIONS: 610Wx340Dx270H





Please Note

If you intend on using the oil filter with solid fats or lard, please contact our head office on (03) 9551 3034 as we can assist you with suitable modifications



Did you know?

You can significantly improve the quality and life of your fryer oil by using a Royston® OF-28 Oil Filter and Magnesol® Filter Powder. To find out more, please see the Royston® Catalogue.



What is Magnesol®?

Magnesol® "Frying Oil Saver" is a safe, pure white compound that meets the food-grade specifications of the U.S. Food and Drug Administration (FDA), National Sanitation Foundation (NSF), and the Joint Expert Committee on Food Additives of the World Health Organisation. Magnesol® removes both solid and dissolved impurities from used oil to give it extra life. Your oil stays fresh, clear and sparkling clean so you can fry light, crisp and golden delicious fried foods.

How does Magnesol® work?

Magnesol® is activated! It is different than other purifier on the market. Filtering every day with Magnesol® not only removes food debris from oil but it also extracts soluble liquid impurities that contribute to off-flavours and odours of used oil. Unlike ordinary filter powders, Magnesol® particles act like a magnet to attract and remove the dissolved tastes and odour that can spoil fried food.

Why use Magnesol®?

Magnesol® does more than simple filtration. During frying, oil surrounds and soaks into food: actually becoming a part of it. As oil breaks down, dissolved impurities also soak into food affecting its taste, texture and appearance. Daily use of Magnesol® extracts the off-flavours and odours dissolved in oil so that only fresh, clear and sparkling clean oil touches your fried food. So, cleaner oil means better tasting fried food and longer life. Longer oil life means lower frying cost and higher profits for you!

MAGNESOL
Global Leader in Frying Oil Filtration

Reduce your oil purchases by 50% or more

- Dramatically improves frying oil & product quality
- Controls the oil degradation process
- Expert Field Service Training & Support

Oil Filtered without Magnesol®
Days of Oil Life: 4 (represented by 4 yellow droplets)

Oil Filtered with Magnesol®
Days of Oil Life: 8 (represented by 8 yellow droplets)

Optimum Frying Conditions



SINGLE TANK BENCHTOP FRYER

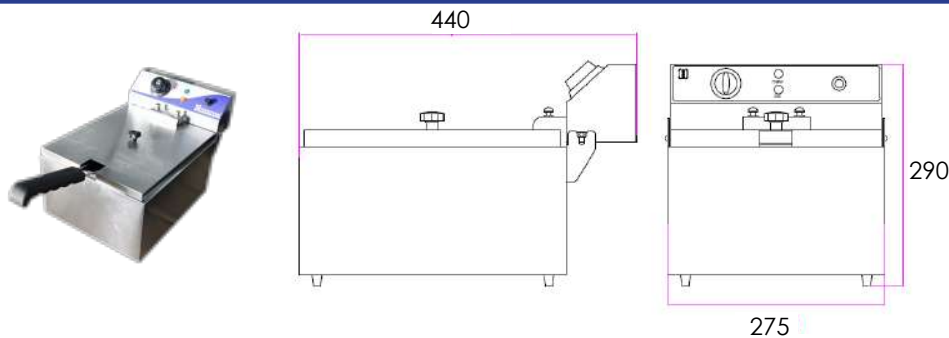

MODEL: FRY101-10
DIMENSIONS: 275Wx440Dx290H
OUTPUT: 2.2KW
WEIGHT: 6 kg

- 6 litre tank capacity - Removable tank - Element guard - Stainless steel construction - Thermostat controlled - Insulated handles - Temperature safety cutout - Includes 1 basket - 240V 10A 50Hz



SINGLE TANK BENCHTOP FRYER

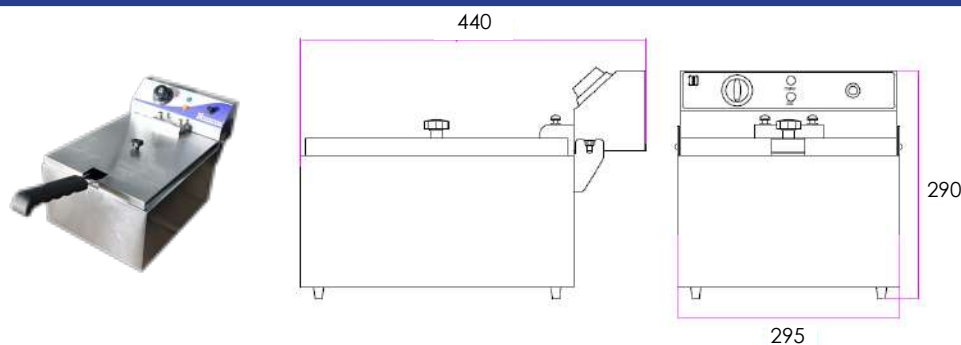

MODEL: FRY101-15
DIMENSIONS: 295Wx440Dx290H
OUTPUT: 3KW
WEIGHT: 6 kg

- 6 litre tank capacity - Removable tank - Element guard - Stainless steel construction - Thermostat controlled - Insulated handles - Temperature safety cutout - Includes 1 basket - 240V 15A 50Hz



DOUBLE TANK BENCHTOP FRYER

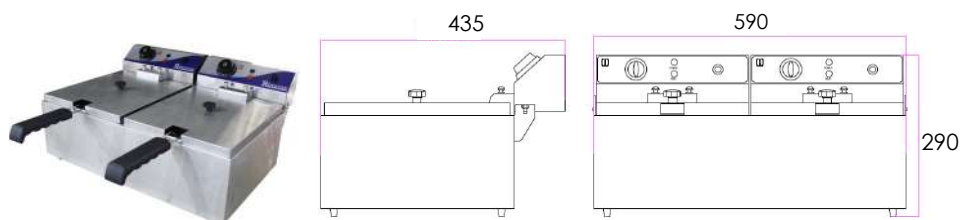

MODEL: FRY102-10
DIMENSIONS: 590Wx435Dx290H
OUTPUT: 2.2+2.2KW
WEIGHT: 9.5 kg

- 6 litre tank capacity (12 litres in total) - Removable tank - Element guard - Stainless steel construction - Thermostat controlled - Insulated handles - Temperature safety cutout - Includes 2 baskets - 240V 10A 50Hz - Unit uses 2x10A plugs - Full load: 19 amps



DOUBLE TANK BENCHTOP FRYER

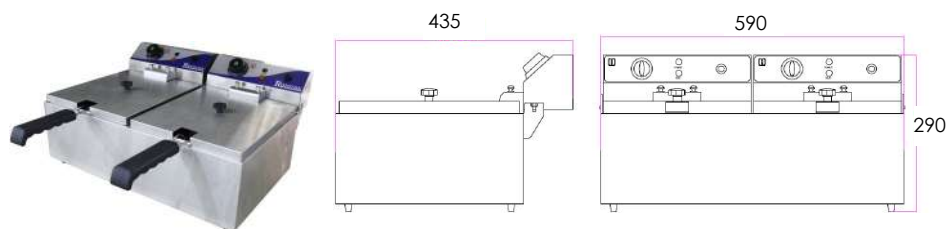

MODEL: FRY102-15
DIMENSIONS: 590Wx435Dx290H
OUTPUT: 3+3KW
WEIGHT: 9.51 kg

- 6 litre tank capacity (12 litres in total) - Removable tank - Element guard - Stainless steel construction - Thermostat controlled - Insulated handles - Temperature safety cutout - Includes 2 baskets - 240V 10A 50Hz - Unit uses 2x10A plugs - Full load: 19 amps



SINGLE TANK FRYER WITH OIL TAP

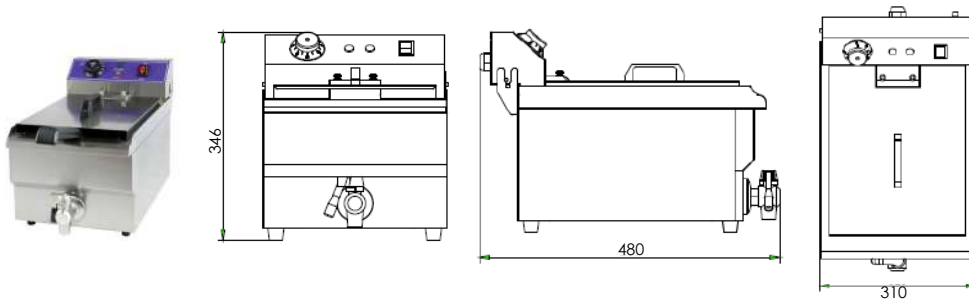

MODEL: FRY - 10LT

DIMENSIONS: 310Wx480Dx345H

OUTPUT: 3KW

WEIGHT: 8 kg

- High quality 430 grade stainless steel construction with mirror finish - Oil tank capacity: 9.8 litres - CE approved - 240V 15A 50Hz

ROYSTON®

DOUBLE TANK FRYER WITH OIL TAP

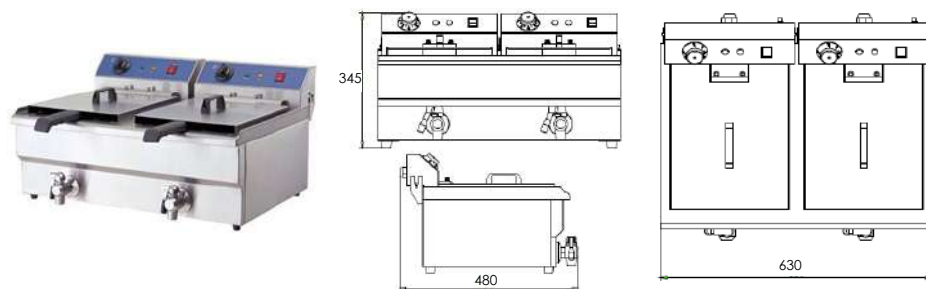

MODEL: FRY - 20LT

DIMENSIONS: 630Wx480Dx345H

OUTPUT: 3+3KW

WEIGHT: 13 kg

- High quality 430 grade stainless steel construction with mirror finish - Oil tank capacity: 9.8+9.8 litres - CE approved - 240V 15A 50Hz - Unit uses 2x15A plugs - Full load: 25 amps

ROYSTON®

DOUGHNUT FRYER

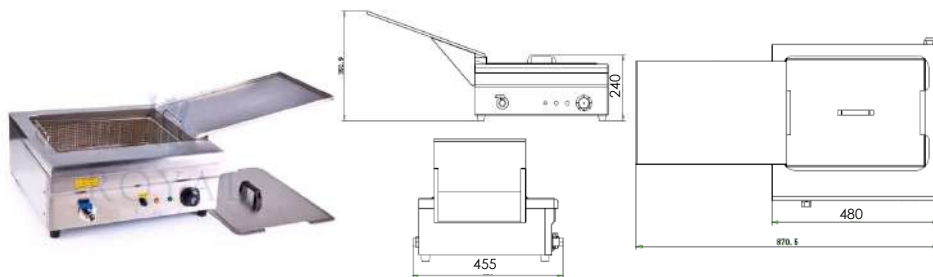

MODEL: DF-15

DIMENSIONS: 480Wx455Dx240H

OUTPUT: 2.4KW

WEIGHT: 14 kg

- High quality stainless steel construction with mirror finish - Oil tank capacity: 15 litres - CE approved - 240V 10A 50Hz

ROYSTON®

STEAMING AND FRYING DUMPLING MACHINE

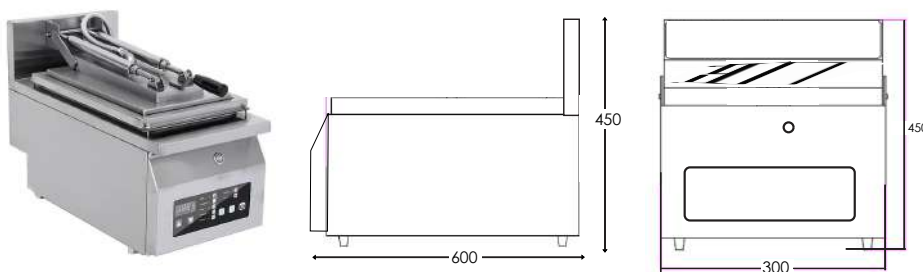

MODEL: DC-06

DIMENSIONS: 300Wx600Dx450H

OUTPUT: 3 Kw

WEIGHT: 30 Kg

Steaming and frying function, - Perfect for Gyoza and Dumplings

ROYSTON®

ELECTRIC HOTPLATE- 500mm



MODEL: HPE500

DIMENSIONS: 500Wx520Dx310H

OUTPUT: 2.4KW

WEIGHT: 30 kg

- Mild steel cooking surface - 500mm cooking surface - Step shaped splash back - 12mm griddle
- CE approved - 240V 10A 50Hz

ROYSTON®

ELECTRIC HOTPLATE- 1000mm

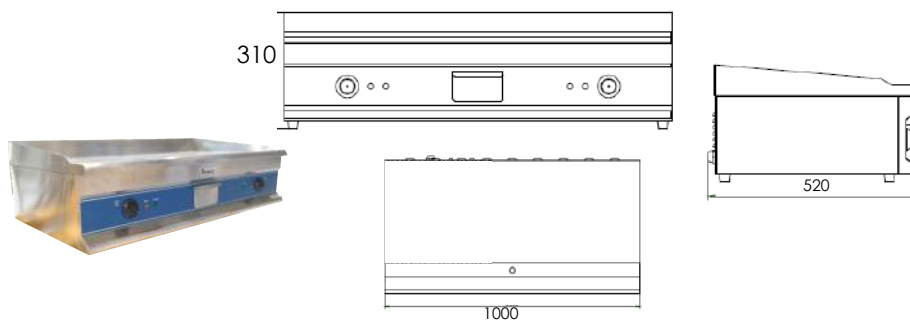

MODEL: HPE1000

DIMENSIONS: 1000Wx520Dx310H

OUTPUT: 2.4KW

WEIGHT: 30 kg

- Mild steel cooking surface - 1000mm cooking surface - Step shaped splash back - 12mm griddle - CE approved - 240V 10A 50Hz - Unit uses 2x10A plugs

ROYSTON®

ELECTRIC CONTACT GRILL - SINGLE

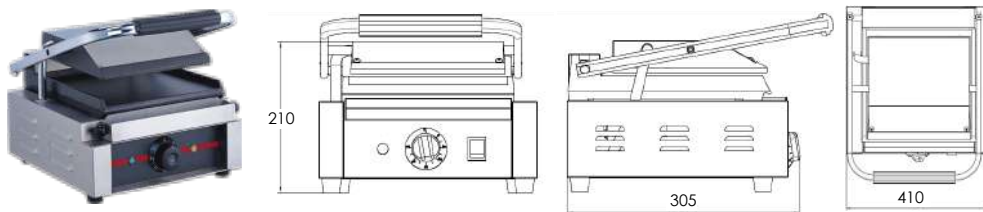

MODEL: PT1-410

DIMENSIONS: 320Wx370Dx230H

OUTPUT: 2.2KW

WEIGHT: 14 kg

- Grooved top/flat bottom - Cast iron griddle plate - Two heating elements - Temperature range: up to 300°C - 240V 15A 50Hz

ROYSTON®

ELECTRIC CONTACT GRILL - DOUBLE

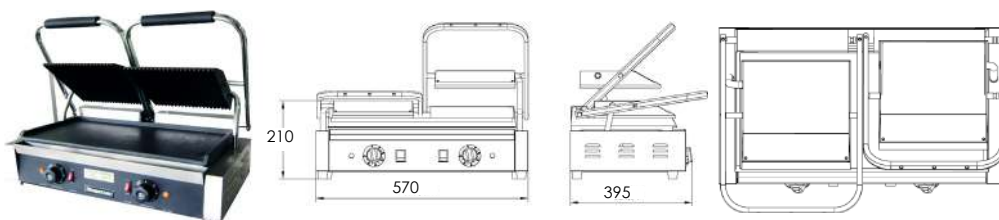

MODEL: PT2-570

DIMENSIONS: 570Wx395Dx210H

OUTPUT: 3.6KW

WEIGHT: 35 kg

- Grooved top/flat bottom - Cast iron griddle plate - Upper grill contact surface: 215Wx212D - Lower grill contact surface: 495Wx245D - Temperature range: up to 300°C - 240V 2x10A 50Hz
- **This unit uses two 10A plugs**

ROYSTON®

ELECTRIC CONTACT GRILL - MILD STEEL

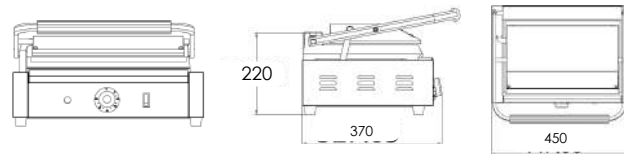

MODEL: PTA-450
DIMENSIONS: 450Wx370Dx220H
OUTPUT: 2.4KW
WEIGHT: 20 kg

- Grooved top/flat bottom - Mild steel giddle plate - Temperature range: up to 300°C
 - 240V 10A 50Hz



GLASS ELEMENT TOASTER - 10AMPS

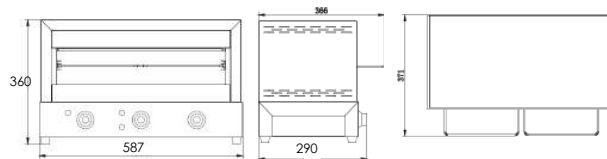

MODEL: GET8-10A
DIMENSIONS: 587Wx290Dx360H
OUTPUT: 2.2KW
WEIGHT: 8 kg

- Top and bottom controller - Includes timer - Stainless Steel construction with mirror finish - 240V 10A 50Hz



GLASS ELEMENT TOASTER - 15AMPS

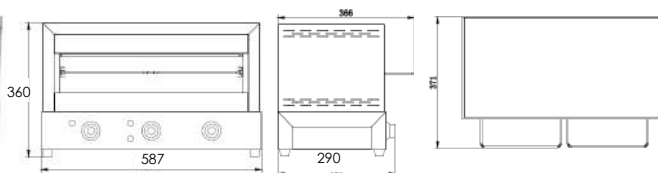

MODEL: GET8-15A
DIMENSIONS: 587Wx290Dx360H
OUTPUT: 3.4KW
WEIGHT: 8 kg

- Top and bottom controller - Includes timer - Stainless Steel construction with mirror finish - 240V 15A 50Hz



FRYER ACCESSORIES



- Fryer basket to suit FRY-101 and FRY-102 series benchtop fryers - Heavy duty insulated handles

MODEL: FRY-BASKET
DIMENSIONS: 190Wx440Dx125H

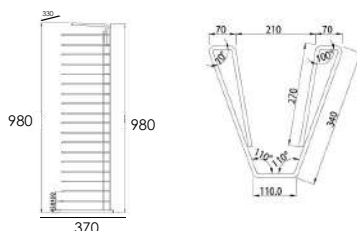
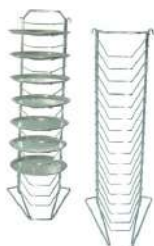

MODEL: PIZZA RACKS
DIMENSIONS: 370Wx330Dx980H
OUTPUT: 4KW
WEIGHT: 5 kg

- Capacity: 18 trays - Heavy duty - Chromed steel - Bench or wall mounted - **Pizza trays shown not included**



Please refer to the Spare Parts and Accessories booklet to see all the available optional extras. "Product" dimensions are given in mm and are approximate. Pictures are for illustrative purposes only. Given information may change without notice. For further information on any line drawings or missing product information, please call our head office on 03 9551 3034. All prices exclude GST. Freight charges apply.

ELECTRIC CONVECTION OVEN

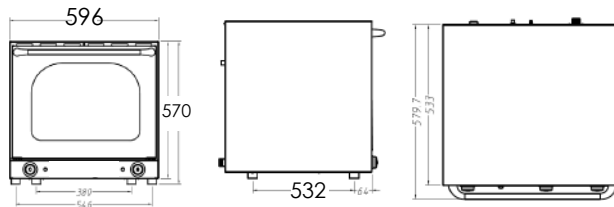
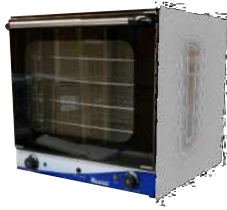

MODEL: ROY-4A

DIMENSIONS: 596Wx600Dx570H

OUTPUT: 2.4KW

WEIGHT: 40 kg

- Chamber size: 460Wx380Dx360H - Tray size: 440Wx320D - Three heating elements - Double glazed glass doors - Timer range: 0-120 mins - Two fans - 4 trays included - Temperature range: 50°C to 300°C - 240V 15A 50Hz

ROYSTON®

ELECTRIC CONVECTION OVEN

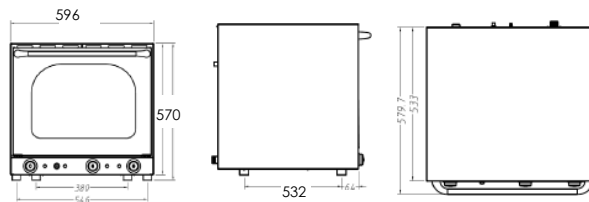

MODEL: ROY-4A-G

DIMENSIONS: 596Wx532Dx570H

OUTPUT: 2.4KW

WEIGHT: 40 kg

Roy-4A-G has Top grill element - Chamber size: 460Wx380Dx360H - Tray size: 440Wx320D - Three heating elements - Double glazed glass doors - Timer range: 0-120 mins - Two fans - 4 trays included - Temperature range: 50°C to 300°C - 240V 10A 50Hz

ROYSTON®

ELECTRIC CONVECTION OVEN

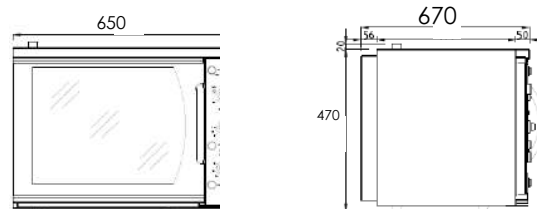

MODEL: ROY-6A

DIMENSIONS: 650Wx670Dx470H

OUTPUT: 2.7KW

WEIGHT: 40 kg

- Comes with 4 trays - Timer 120 min - Fits 1/1 GN Trays - Side opening door - Double glazed glass doors - Trays not included - Temperature range: 50°C to 300°C - 240V 15A 50Hz

ROYSTON®

ELECTRIC CONVECTION OVEN

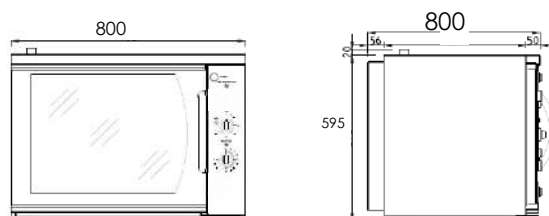

MODEL: ROY-7A

DIMENSIONS: 800Wx800Dx595H

OUTPUT: 3.6 KW

WEIGHT: 48 kg

- Chamber size: 545Wx430Dx385H - Fits 1/1 GN Trays - Side opening door - Double glazed glass doors - Trays not included - Temperature range: 50°C to 300°C - 240V 15A 50Hz

ROYSTON®

ELECTRIC CONVECTION OVEN - 10 AMP

Made in Italy

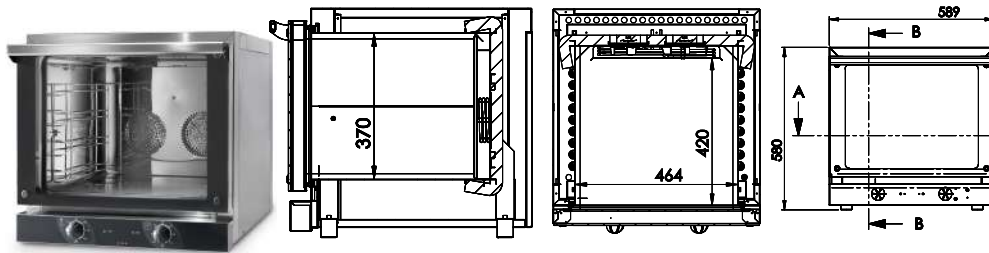

MODEL: A410A
DIMENSIONS: 589Wx660Dx580H
OUTPUT: 2.3 KW
WEIGHT: 33kg

- Chamber size: 464Wx420Dx370H - Fits 1/1 GN Trays - Double glazed glass doors - Trays included - Temperature range: 50°C to 300°C - 240V 10A 50Hz



ELECTRIC CONVECTION OVEN - 15AMP

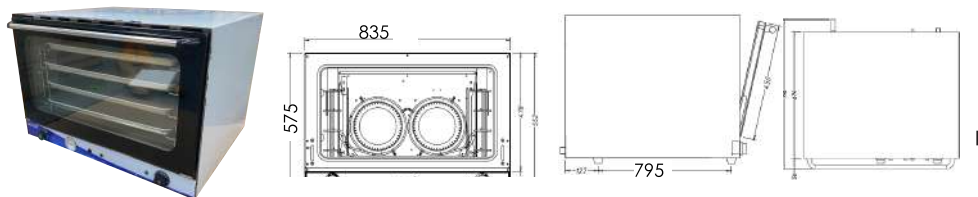

MODEL: ROY-8A
DIMENSIONS: 835Wx795Dx575H
OUTPUT: 3.6KW
WEIGHT: 62 kg

- Chamber size: 700Wx360Dx460H - Tray size: 410Wx590D - Computerised oven - Double glazed glass doors - Steam option included - Temperature range: 50°C to 300°C - 240V 15A 50Hz



ELECTRIC CONVECTION OVEN - 15 AMP

Made in Italy

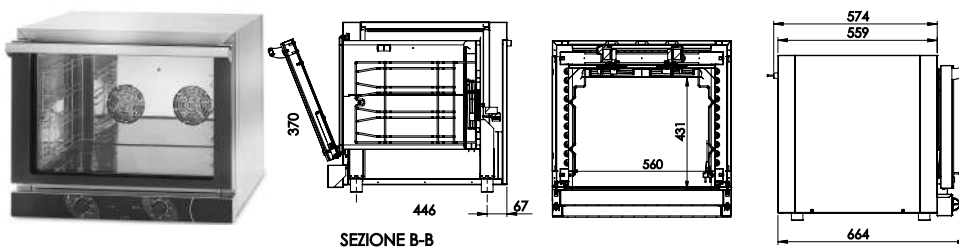

MODEL: A4GN15A
DIMENSIONS: 589Wx660Dx580H
OUTPUT: 3.2 Kw
WEIGHT: 35kg

- Chamber size: 650Hx460Dx350H - Fits 1/1 GN Trays - Double glazed glass doors - Trays included - Temperature range: 50°C to 300°C - 240V 15A 50Hz



MEAT SLICER-250MM

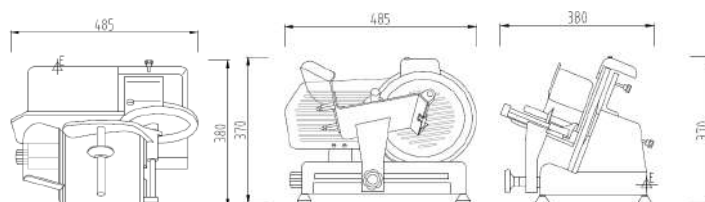

MODEL: ROY250-10A
DIMENSIONS: 470Wx280Dx380H
OUTPUT: 0.32KW
WEIGHT: 16 kg

Blade size: 250mm (10" diameter) - Built-in sharpener - Micrometric thickness control adjustment - Smooth glide - Belt driven - Easy to clean - Tough hand guard - OH&S compliant blade safety guard with lock - 240V 10A 50Hz



MEAT SLICER - 300MM

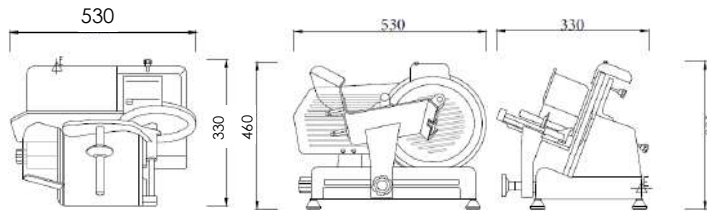

MODEL: ROY300-10A

DIMENSIONS: 530Wx330Dx460H

OUTPUT: 0.42KW

WEIGHT: 24.3 kg

- Blade size: 300mm (12" diameter) - Built-in sharpener - Micrometric thickness control adjustment - Smooth glide - Belt driven - Easy to clean - Tough hand guard - OH&S compliant blade safety guard with lock - 240V 10A 50Hz

ROYSTON®

AUTOMATIC MEAT SLICER - 300MM

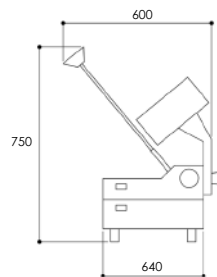

MODEL: ROY300-AUTO

DIMENSIONS: 600Wx640Dx750H

OUTPUT: 0.55KW

WEIGHT: 68 kg

- Blade size: 300mm (12 diameter) - Manual and automatic modes - micrometric thickness control adjustment: 0mm-15mm - Easy to use and clean - 240V 10A 50Hz

ROYSTON®

BOWL CUTTER

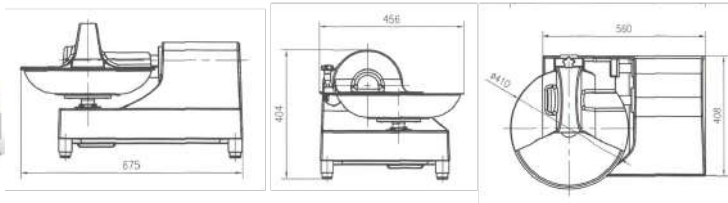

MODEL: BC-670

DIMENSIONS: 670Wx480Dx410H

OUTPUT: 370W

WEIGHT: 36 kg

- Multi-function chopping machine - Butterfly-type blade ensures fast speed, and high efficiency - Convenient multiple locking blade - Automatic temperature control protection

ROYSTON®

MEAT MINCER - 120KG/HR

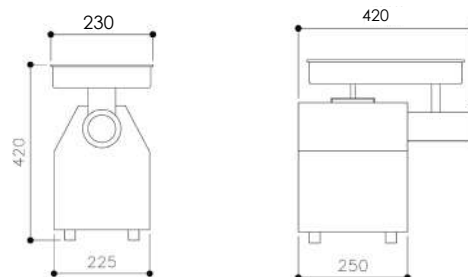

MODEL: MM-12

DIMENSIONS: 230Wx420Dx550H

OUTPUT: 0.55KW

WEIGHT: 68 kg

- Heavy duty - Capacity: 120 kg/hr - Stainless steel construction - Forward/reverse function - Overload protection - 240V 10A 50Hz

ROYSTON®

MEAT MINCER - 220KG/HR

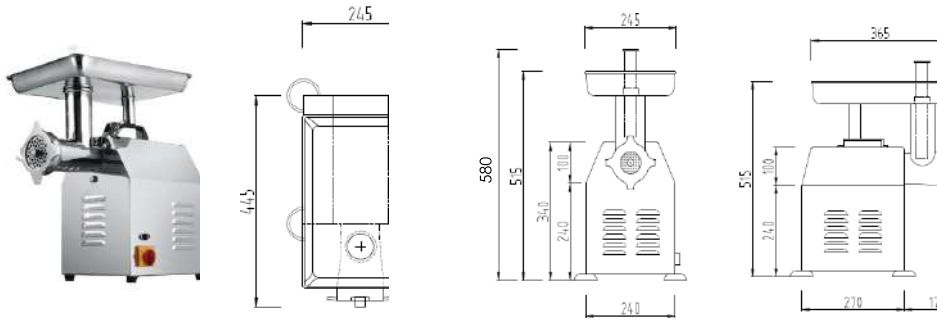

- Heavy duty - Capacity: 220 kg/hr - Stainless steel construction - Forward/reverse function - Overload protection - 240V 10A 50Hz

MODEL: MM-22

DIMENSIONS: 240Wx460Dx580H

OUTPUT: 0.9KW

WEIGHT: 33 kg

ROYSTON®

MEAT MINCER - 320KG/HR

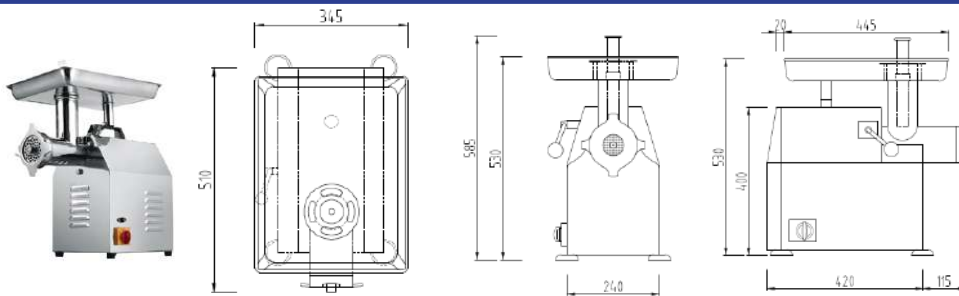

- Heavy duty meat mincer - Capacity: 320 kg/hr - Stainless steel construction - Forward/reverse function - Overload protection - 240V 10A 50Hz

MODEL: MM-32

DIMENSIONS: 350Wx530Dx160H

OUTPUT: 1.5KW

WEIGHT: 62 kg

ROYSTON®

HORIZONTAL PIZZA DOUGH ROLLER

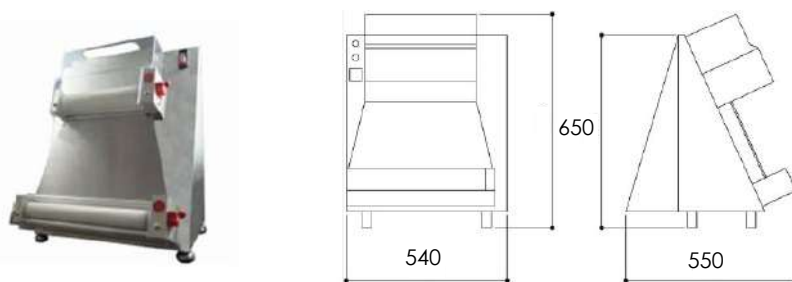

- Suited for pizza sizes between 100-400mm - Dough capacity: 50g-500g - Includes foot pedal - 240V 10A 50Hz

MODEL: PR-HORIZONTAL

DIMENSIONS: 540Wx550Dx650H

OUTPUT: 0.37KW

WEIGHT: 39 kg

ROYSTON®

ANGLED PIZZA DOUGH ROLLER

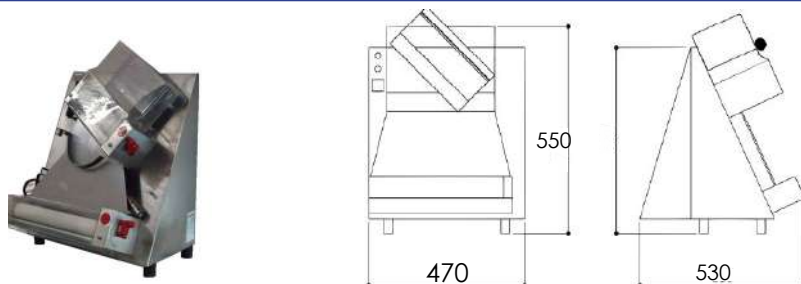

- Suited for pizza sizes between 100-400mm - Dough capacity: 50g-500g - Includes foot pedal - 240V 10A 50Hz

MODEL: PR-ANGLE

DIMENSIONS: 470Wx530Dx550H

OUTPUT: 0.37KW

WEIGHT: 37 kg

ROYSTON®

MILKSHAKE MAKER - WHITE

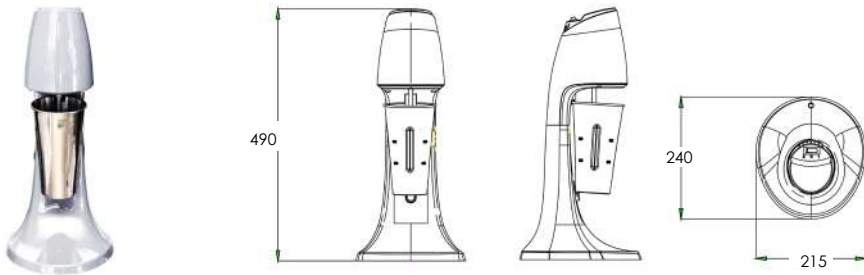

MODEL: MSW-300

DIMENSIONS: 215Wx240Dx490H

OUTPUT: 0.3KW

WEIGHT: 2 kg

- Die cast Zinc alloy base - High quality stainless steel cup - Safety microswitch: unit operates only with cup in place - Powerful 300W motor - 0.9L cup capacity - CE approved - 240V 10A 50Hz

ROYSTON®

MILKSHAKE MAKER - BLUE

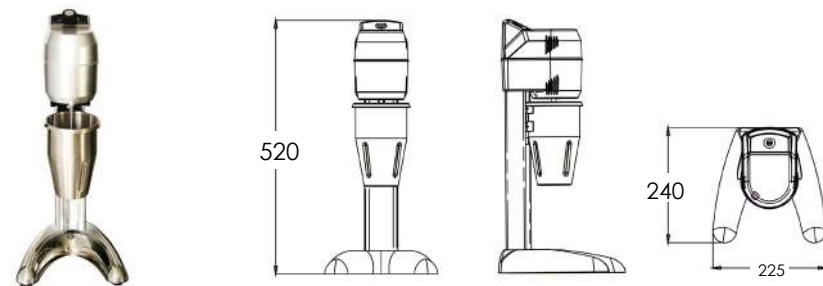

MODEL: MSA-300

DIMENSIONS: 225Wx240Dx520H

OUTPUT: 0.3KW

WEIGHT: 2 kg

- Die cast base - High quality stainless steel cup - Stepless speed regulation - Safety microswitch: unit operates only with cup in place - Powerful 300W motor - 0.9L cup capacity - CE approved - 240V 10A 50Hz

ROYSTON®

MILKSHAKE MAKER - ALUMINIUM FINISH

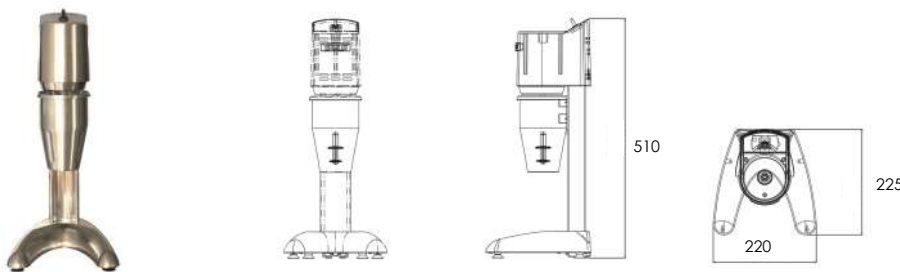

MODEL: MSZ-300

DIMENSIONS: 220Wx225Dx510H

OUTPUT: 0.3KW

WEIGHT: 2 kg

- Die cast base - High quality stainless steel cup - Two speed, High/Low switch - Safety microswitch: unit operates only with cup in place - Powerful 300W motor - 0.9L cup capacity - CE approved - 240V 10A 50Hz

ROYSTON®

POPCORN MACHINE

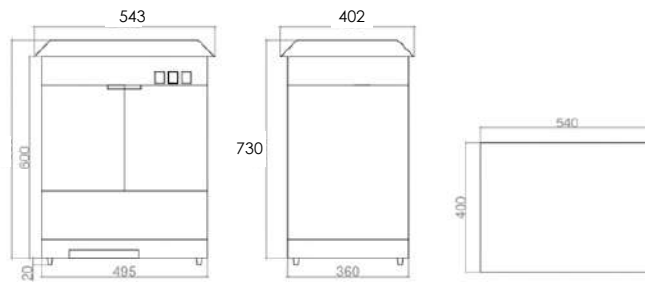

MODEL: PC-T

DIMENSIONS: 543Wx402Dx730H

OUTPUT: 22KW

WEIGHT: 22 kg

- Fully toughened glass - Highly efficient heating system - Infrared warming light - Drawer type crumb tray - Easy to clean - 240V 10A 50Hz



BENCHTOP ICE MAKER

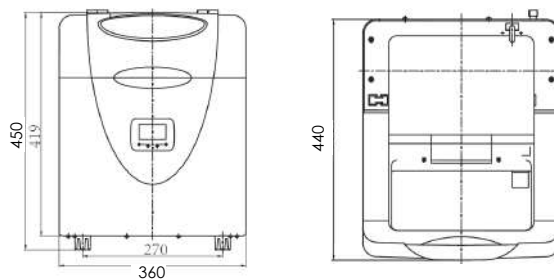

MODEL: BTICE15

DIMENSIONS: 360Wx440Dx450H

OUTPUT: 0.2KW

WEIGHT: 22 kg

- Production capacity: 15kg/24hr - 2 kg ice storage capacity - No plumbing required - Refrigerant R134a - 240V 10A 50Hz



FAIRY FLOSS

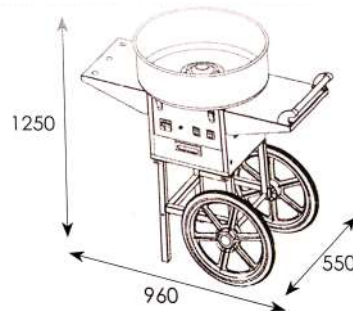

MODEL: CF-520

DIMENSIONS: 960Wx550Dx1250H

OUTPUT: 1.03 Kw

WEIGHT: 21 kg

Candy Floss machine with wheels - cover dome diameter 520mm - Unit includes plastic cover/dome.



MILKSHAKE ACCESSORIES



- Cup to suit MS- Series Milk Shake Makers - High quality polycarbonate construction

MODEL: MS-PCUP

DIMENSIONS: 115Wx115Dx160H



- Cup to suit MS- Series Milk Shake Makers - High quality stainless steel construction

MODEL: MS-SSCUP

DIMENSIONS: 113Wx113Dx162H



**NEW
MODELS**

MITCHEL REFRIGERATION

- Stainless Steel Upright Refrigerators
- Stainless Steel Upright Freezers
- Glass Door Refrigerators & Freezer
- Undercounter Refrigerators
- Glass Door Undercounter Freezers
- Undercounter Freezers
- Pizza & Noodle Bars
- Salad & Sandwich Bars
- Refrigerated Displays - Three Tier
- Refrigerated Displays - Four Tier

ITALFRIDGE

- Pizza Make up
- Stainless Steel Upright Refrigerators
- Stainless Steel Upright Freezers



STAINLESS STEEL SINGLE DOOR REFRIGERATOR

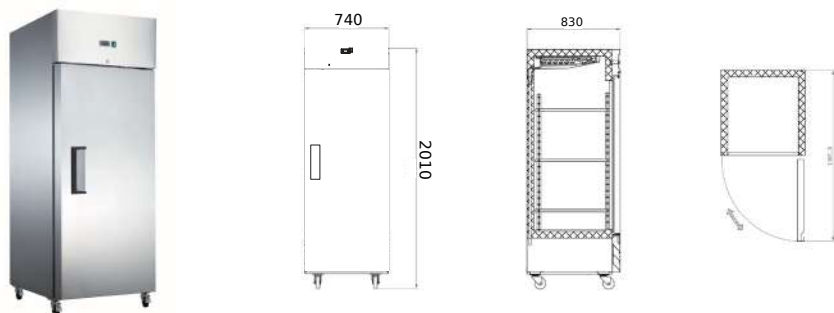

MODEL: R584FDGN-TOP

DIMENSIONS: 740Wx830Dx2010H

OUTPUT: 300W

WEIGHT: 121 kg



- Painted aluminium interior - 650 litre capacity - Fits GN trays - Adjustable shelves for extra container diversity - Frost free design - On castors - Digital temperature control - Fan cooled - Refrigerant R134a - Temperature range: -2°C ~ 8°C - Ambient temperature: 43°C - 240V 10A 50Hz

STAINLESS STEEL SINGLE DOOR REFRIGERATOR

Made in Italy

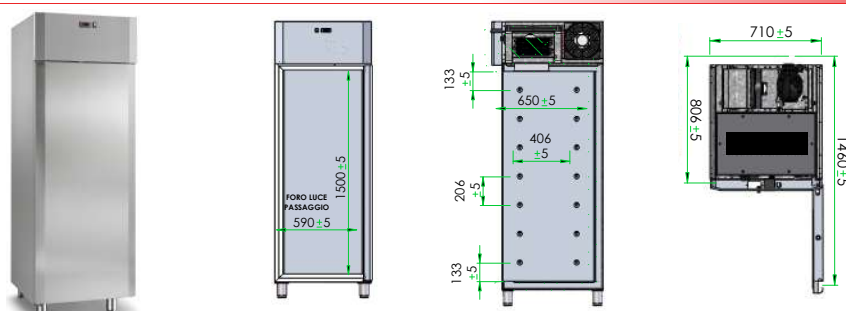

MODEL: IFR700-1D

DIMENSIONS: 710Wx800Dx2100H

OUTPUT: 385W

WEIGHT: 96 kg

2 YEAR WARRANTY
(2 YEAR PARTS & 1 YEAR LABOUR)



Made in Italy

Stainless-steel interior and exterior; - Insulation thickness: 60 mm; - Self-closing doors with magnetic gasket.; - Standard removable monobloc and tropicalised refrigeration unit (+40° room temperature and 60% relative humidity) using R452A gas; Automatic defrosting and condensate evaporation; 0/+10°C upright chiller; On castors.

STAINLESS STEEL SINGLE DOOR FREEZER

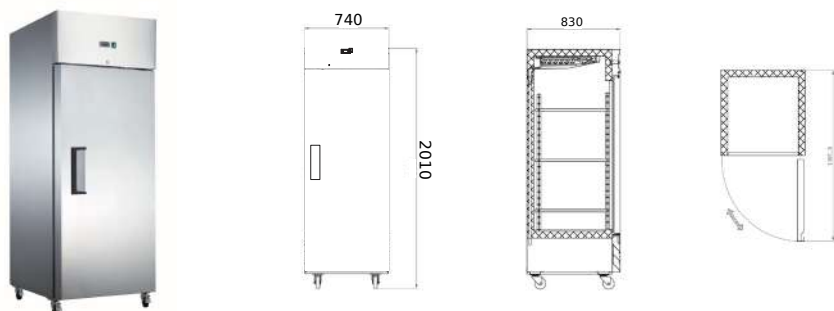

MODEL: F584FDGN- TOP

DIMENSIONS: 740Wx830Dx2010H

OUTPUT: 630W

WEIGHT: 126 kg



- Painted aluminium interior - 650 litre capacity - Fits GN trays - Adjustable shelves for extra container diversity - Frost free design - On castors - Digital temperature control - Fan cooled - Refrigerant R404A - Temperature range: -18C to -22C - Ambient temperature 43C - 240V 10A 50Hz

STAINLESS STEEL SINGLE DOOR FREEZER

Made in Italy

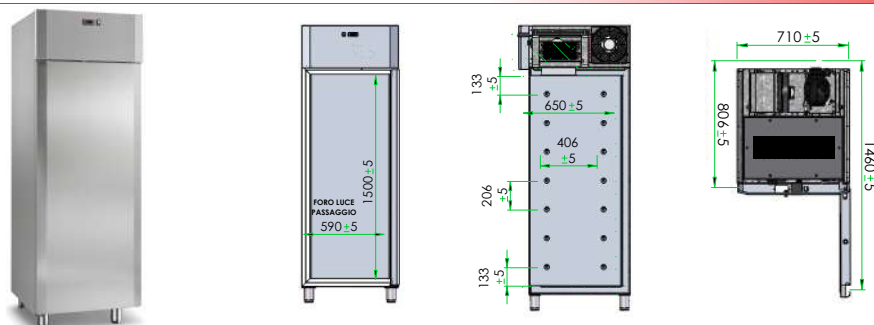

MODEL: IFF700-1D

DIMENSIONS: 710Wx800Dx2100H

OUTPUT: 650W

WEIGHT: 96 kg

2 YEAR WARRANTY
(2 YEAR PARTS & 1 YEAR LABOUR)



Made in Italy

Stainless-steel interior and exterior; - Insulation thickness: 60 mm; - Self-closing doors with magnetic gasket.; - Standard removable monobloc and tropicalised refrigeration unit (+40° room temperature and 60% relative humidity) using R452A gas; Automatic defrosting and condensate evaporation; -18°C / -22°C upright freezer; On castors.

STAINLESS STEEL TWO DOOR REFRIGERATOR

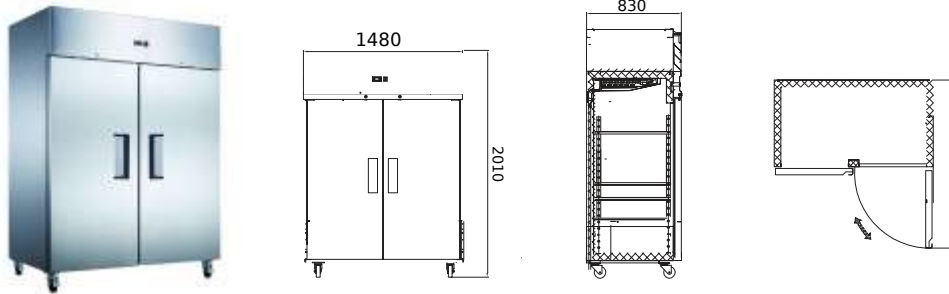

MODEL: R1170FDGN-TOP

DIMENSIONS: 1480Wx830Dx2010H

OUTPUT: 500W

WEIGHT: 188 kg



- Painted aluminium interior - 1300 litre capacity - Fits GN trays - Adjustable split shelves for extra container diversity - Frost free design - On castors - Digital temperature control - Fan cooled - Refrigerant R134a - Temperature range: -2°C ~ 8°C - Ambient temperature: 43°C - 240V 10A 50Hz

STAINLESS STEEL TWO DOOR UPRIGHT REFRIGERATOR

Made in Italy

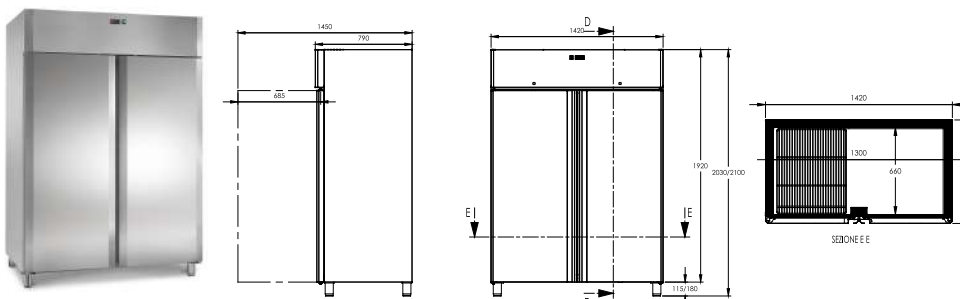

MODEL: IFR1400-2D

DIMENSIONS: 1420Wx800Dx2030H

OUTPUT: 570W

WEIGHT: 150 kg

2 YEAR WARRANTY
(2 YEAR PARTS & 1 YEAR LABOUR)

Made in Italy

Stainless-steel interior and exterior. Galvanised steel external base, top and back; - High-pressure injected polyurethane, without the use of dangerous CFCs; Insulation thickness: 60 mm; - Self-closing doors with magnetic gasket. Thickness: 60 mm; Front electronic control panel with 1 NTC thermistor in TN, and 2 NTC thermistors in BT; - 18°C / -22°C upright freezer; On Castors

STAINLESS STEEL TWO DOOR FREEZER

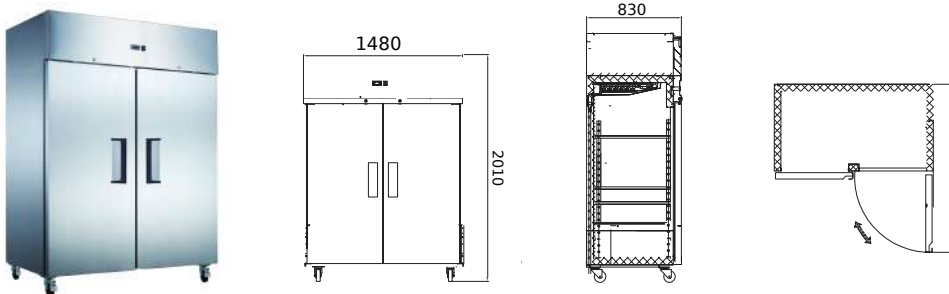

MODEL: F1170FDGN-TOP

DIMENSIONS: 1480Wx830Dx2010H

OUTPUT: 1300W

WEIGHT: 201 kg



- Painted aluminium interior - 1300 litre capacity - Fits GN trays - Adjustable split shelves for extra container diversity - Frost free design - On castors - Digital temperature control - Fan cooled - Refrigerant R404a - Temperature range: 18°C to 22°C - Ambient temperature: 43°C - 240V 10A 50Hz

STAINLESS STEEL TWO DOOR UPRIGHT FREEZER

Made in Italy

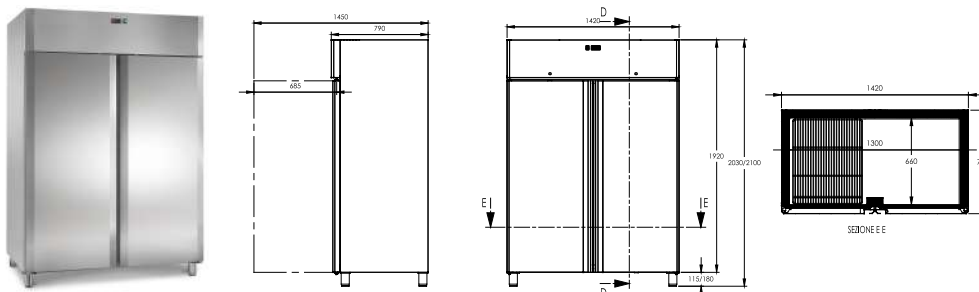

MODEL: IFF1400-2D

DIMENSIONS: 1420Wx835Dx2100H

OUTPUT: 700W

WEIGHT: 165 kg

2 YEAR WARRANTY
(2 YEAR PARTS & 1 YEAR LABOUR)

Made in Italy

Stainless-steel interior and exterior; - Insulation thickness: 60 mm; - Self-closing doors with magnetic gasket; - Standard removable monobloc and tropicalised refrigeration unit (+40° room temperature and 60% relative humidity) using R452A gas; Automatic defrosting and condensate evaporation; 0/+10°C upright chiller; -18°C / -22°C upright freezer; On Castors

STAINLESS STEEL FOUR - HALF DOOR REFRIGERATOR

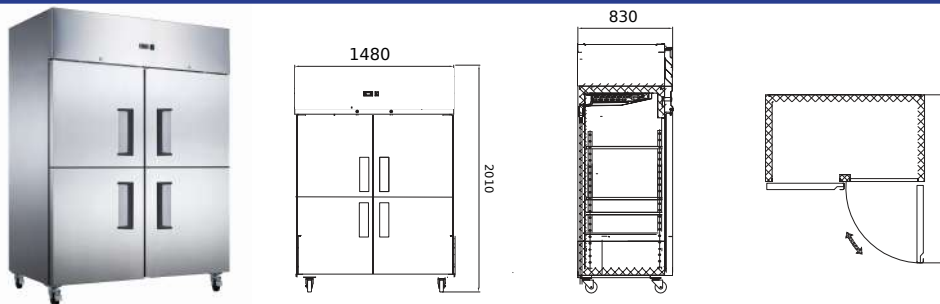

-Painted aluminium interior - 1300 liter capacity - Fits GN Trays - Adjustable split shelves for extra container diversity - frost free design - On castors - digital temperature control - Fan cooled - Refrigerant R134a - Temperature range: -2C ~ 8C - Ambient temperature: 43C - 240V 10A 50 Hz

MODEL: R1170HDGN-TOP

DIMENSIONS: 1480Wx830Dx2010H

OUTPUT: 600W

WEIGHT: 218 kg



STAINLESS STEEL SIX - HALF DOOR REFRIGERATOR

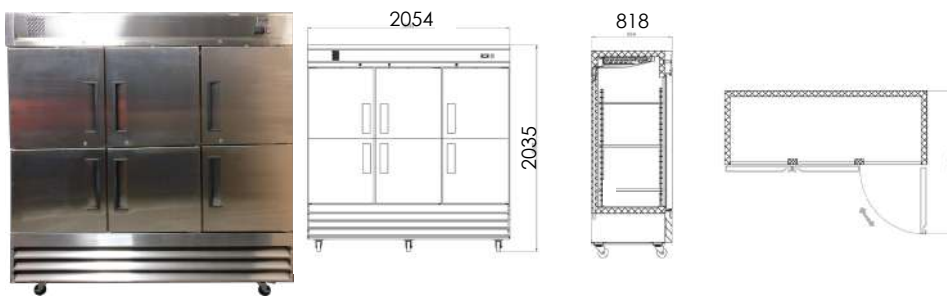

-Painted aluminium interior - 1881 liter capacity - Fits GN Trays - Adjustable split shelves for extra container diversity - frost free design - On castors - digital temperature control - Fan cooled - Refrigerant R134a - Temperature range: 0°C ~ 10°C - Ambient temperature: 40°C - 240V 10A 50 Hz

MODEL: R1880HDGN

DIMENSIONS: 2054Wx818Dx2035H

OUTPUT: 600W

WEIGHT: 218 kg



STAINLESS STEEL FOUR-HALF DOOR FREEZER

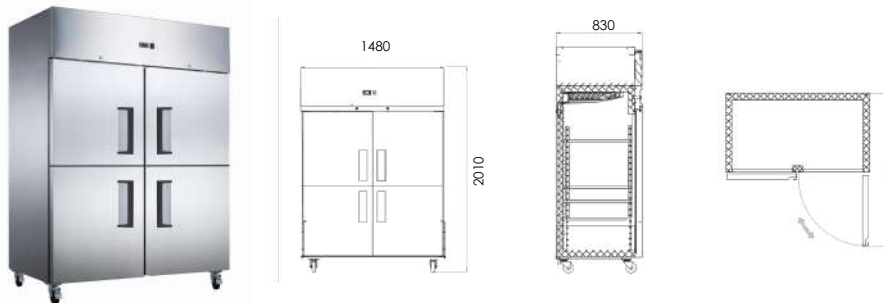

- Painted aluminium interior - 1300 litre capacity -Adjustable split shelves for convenient storage of different size containers - Fits GN trays container diversity - Frost free design - On castors - Digital temperature control - Fan cooled - Refrigerant R404a - Temperature range -18°C to -22°C - Ambient temperature: 43°C - 240V10A 50Hz

MODEL: F1170HDGN-TOP

DIMENSIONS: 1480Wx830Dx2010H

OUTPUT: 1040W

WEIGHT: 218 kg

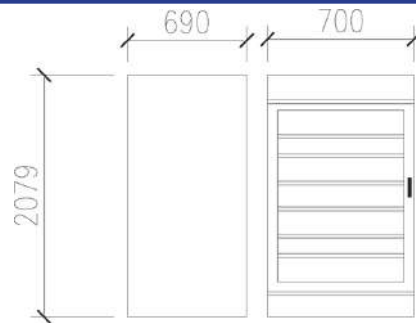

ONE DOOR REFRIGERATOR

**MODEL:** 1DC540**DIMENSIONS:** 700Wx690Dx2079H**OUTPUT:** 522W**WEIGHT:** 83 kg

- Forced air circulation - Adjustable shelves - Interior LED lights - Universal wheels front and back - Interior LED lights - Self closing door - Self evaporating drip tray
-Capacity 540Lt - Temp 1°C to 10°C (Amb +38°C)

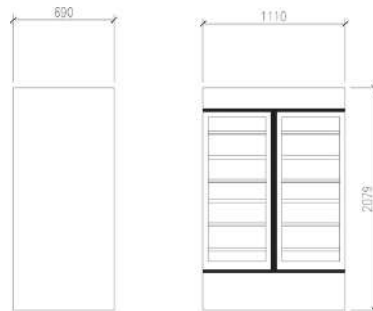

TWO DOOR REFRIGERATOR - SWING DOORS

**MODEL:** PG 1000-R-ENT**DIMENSIONS:** 1110Wx690Dx2079H**OUTPUT:** 768W**WEIGHT:** 123 kg

- 1000 litre capacity - Self closing doors - Digital temperature control - Frost free design - Comes on casters
-Capacity 1000Lt - Temp 1°C to 10°C (Amb +38°C)

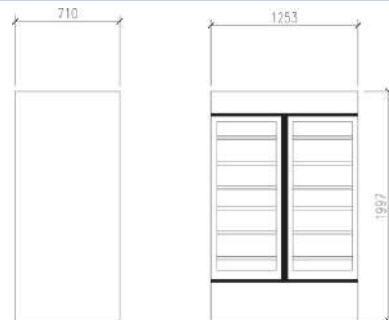

TWO DOOR REFRIGERATOR

**MODEL:** PG 1000-R**DIMENSIONS:** 1253Wx710Dx1997H**OUTPUT:** 672W**WEIGHT:** 179 kg

Forced air circulation - Adjustable shelves - Interior LED lights - Universal wheels, front with brake - Double glazing tempered glass - Self closing door - Self evaporating drip tray
-Capacity 1000Lt - Temp 1°C to 10°C (Amb +38°C)

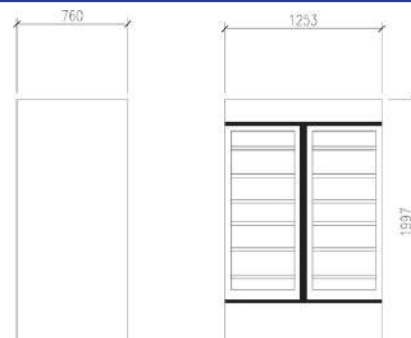

TWO DOOR FREEZER

**MODEL:** PG 960-F**DIMENSIONS:** 1253Wx760Dx1997H**OUTPUT:** 1517W**WEIGHT:** 240 kg

Forced air circulation - Adjustable shelves - Interior LED lights - Universal wheels, front and back - Three pane glass with heated film - Self closing door - Self evaporating drip tray
-Capacity 960Lt - Temp -25°C to -18°C (Amb +32°C)



TWO DOOR UNDERCOUNTER REFRIGERATION

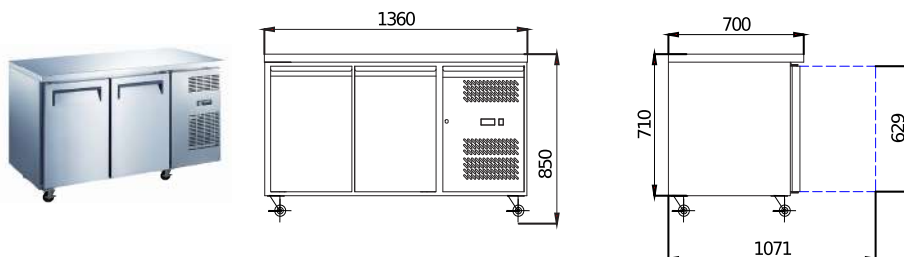

MODEL: UB320-R

DIMENSIONS: 1360Wx700Dx850H

OUTPUT: 385W

WEIGHT: 112 kg



- 318 litre capacity - Electronic thermostat - Fully adjustable shelves - Frost free design - Self closing swing doors - Ventilated cooling system - Stainless steel construction - On castors - R134a refrigerant - Temperature range: 0°C to 10°C - Ambient temperature: 43°C - 240V 10A 50Hz

THREE DOOR UNDERCOUNTER REFRIGERATION

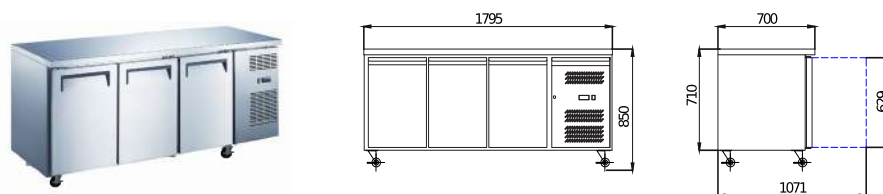

MODEL: UB500-R

DIMENSIONS: 1795Wx700Dx850H

OUTPUT: 410W

WEIGHT: 137 kg



- 497 litre capacity - Electronic thermostat - Fully adjustable shelves - Frost free design - Self closing swing doors - Ventilated cooling system - Stainless steel construction - On castors - R134a refrigerant - Temperature range: 0°C to 10°C - Ambient temperature: 43°C - 240V 10A 50Hz

FOUR DOOR UNDERCOUNTER REFRIGERATION

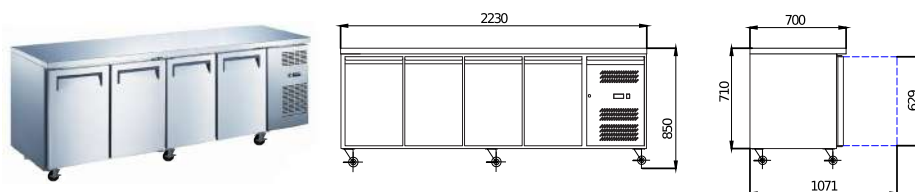

MODEL: UB645-R

DIMENSIONS: 2230Wx700Dx850H

OUTPUT: 385W

WEIGHT: 155 kg



- 645 litre capacity - Electronic thermostat - Fully adjustable shelves - Frost free design - Self closing swing doors - Ventilated cooling system - Stainless steel construction - On castors - R134a refrigerant - Temperature range: 0°C to 10°C - Ambient temperature: 43°C - 240V 10A 50Hz

TWO DOOR UNDERCOUNTER REFRIGERATION WITH GLASS DOORS



MODEL: GUB320-R

DIMENSIONS: 1360Wx700Dx850H

OUTPUT: 385W

WEIGHT: 112 kg



- 318 litre capacity - Electronic thermostat - Fully adjustable shelves - Frost free design - Self closing swing doors - Ventilated cooling system - LED lighting - Stainless steel construction - On castors - R134a refrigerant - Temperature range: 0°C to 10°C - Ambient temperature: 38°C - 240V 10A 50Hz



Please refer to the Spare Parts and Accessories booklet to see all the available optional extras. "Product" dimensions are given in mm and are approximate. Pictures are for illustrative purposes only. Given information may change without notice. For further information on any line drawings or missing product information, please call our head office on 03 9551 3034. All prices exclude GST. Freight charges apply.

THREE DOOR UNDERCOUNTER REFRIGERATION WITH GLASS DOORS



MODEL: GUB500-R

DIMENSIONS: 1795Wx700Dx850H

OUTPUT: 410W

WEIGHT: 137 kg



- 497 litre capacity - Electronic thermostat - Fully adjustable shelves - Frost free design - Self closing swing doors - Ventilated cooling system - LED lighting - Stainless steel construction - On castors - R134a refrigerant - Temperature range: 0°C to 10°C - Ambient temperature: 38°C - 240V 10A 50Hz

ONE DOOR UNDERCOUNTER FREEZERS

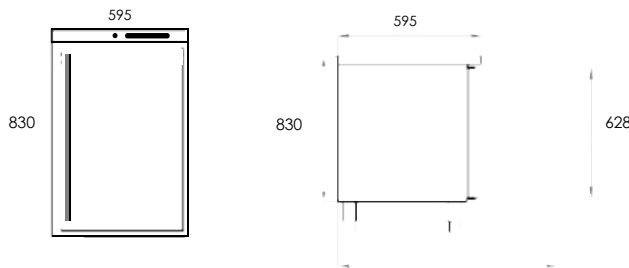

MODEL: UB121-F

DIMENSIONS: 595Wx628Dx830H

OUTPUT: 220-240V/50H

WEIGHT: 137 kg



- 161 litre capacity - Electronic thermostat - Stainless steel construction - On castors - R134a refrigerant - Temperature range: 2°C to 8°C - Ambient temperature: 32°C - 240V 10A 50Hz

TWO DOOR UNDERCOUNTER FREEZERS

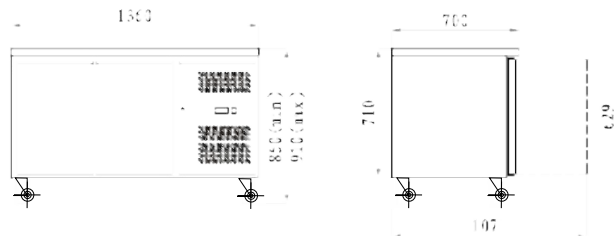

MODEL: UB320-F

DIMENSIONS: 1360Wx700Dx850H

OUTPUT: 350W

WEIGHT: 88 kg



- 318 litre capacity - Electronic thermostat - Fully adjustable shelves - Frost free design - Self closing swing doors - Ventilated cooling system - Stainless steel construction - On castors - R134A refrigerant - Temperature range: -18°C to -20°C - Ambient temperature: 38°C - 240V 10A 50Hz

THREE DOOR UNDERCOUNTER FREEZERS



MODEL: UB500-F

DIMENSIONS: 1800Wx700Dx850H

OUTPUT: 630W

WEIGHT: 100 kg



- 497 litre capacity - Electronic thermostat - Fully adjustable shelves - Frost free design - Self closing swing doors - Ventilated cooling system - Stainless steel construction - On castors - R134A refrigerant - Temperature range: -18°C to -20°C - Ambient temperature: 38°C - 240V 10A 50Hz

THREE DOOR PIZZA BAR

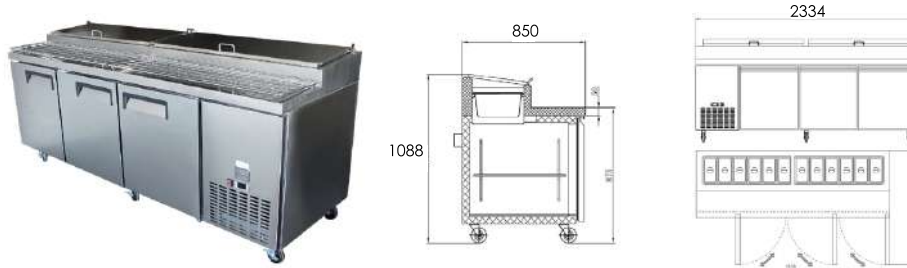

MODEL: PIZZA-3D-E

DIMENSIONS: 2334Wx850Dx1088H

OUTPUT: 760W

WEIGHT: 200 kg

- 878 litre capacity - Self closing swing doors - Frost free - Side mounted motor - Adjustable shelves - Ventilated cooling system - Stainless steel construction - On castors - R134a refrigerant - Temperature range: 0°C to 10°C - Includes wired rack - Can be ordered with canopy (optional: extra charges apply) - Aluminium internal pans not included - Ambient temperature: 32°C - 240V 10A 50Hz.



TWO DOOR PIZZA BAR INCLUDING INGREDIENTS DISPLAY

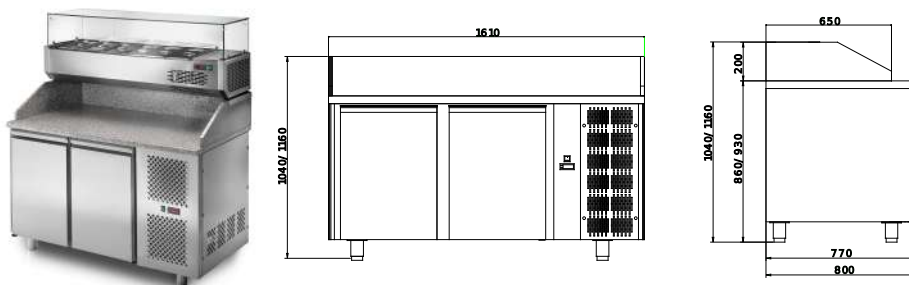

MODEL: 1FPZA-2D & 1FPZA2D-TOP

DIMENSIONS: 1610Wx800Dx1160H

OUTPUT: 380W

WEIGHT: 209 kg

- Refrigerated unit for food-safe polypropylene containers 600 x 400 mm; Net Capacity 288L Depth 800 mm; Temperature 0/+10 C:- The Pizza counter can be paired with chilled display cases with independent unit;- Granite counter top and insulated undercounter. 2 x 10 Amp Plugs

2 YEAR WARRANTY
(2 YEAR PARTS & 1 YEAR LABOUR)

Made in Italy

THREE DOOR PIZZA BAR INCLUDING INGREDIENTS DISPLAY

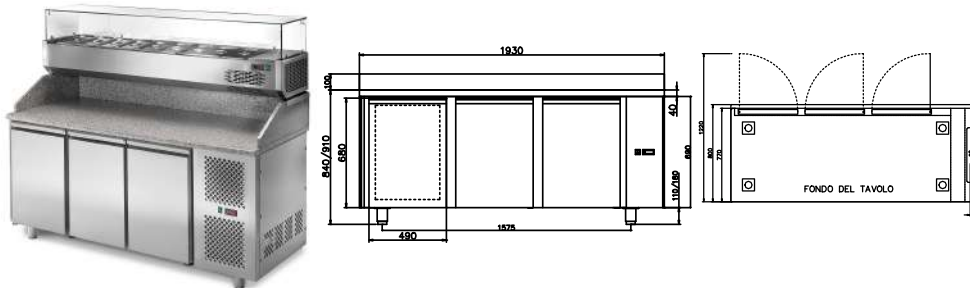

MODEL: 1FPZA-3D & 1FPZA3D-TOP

DIMENSIONS: 2154Wx800Dx1040H

OUTPUT: 380W

WEIGHT: 290 kg

- Refrigerated unit for food-safe polypropylene containers 600 x 400 mm; Net Capacity 432L Depth 800 mm; Temperature 0/+10 C:- The Pizza counter can be paired with chilled display cases with independent unit;- Granite counter top and insulated undercounter. 2 x 10 Amp Plugs

2 YEAR WARRANTY
(2 YEAR PARTS & 1 YEAR LABOUR)

Made in Italy

FOUR DOOR PIZZA BAR INCLUDING INGREDIENTS DISPLAY

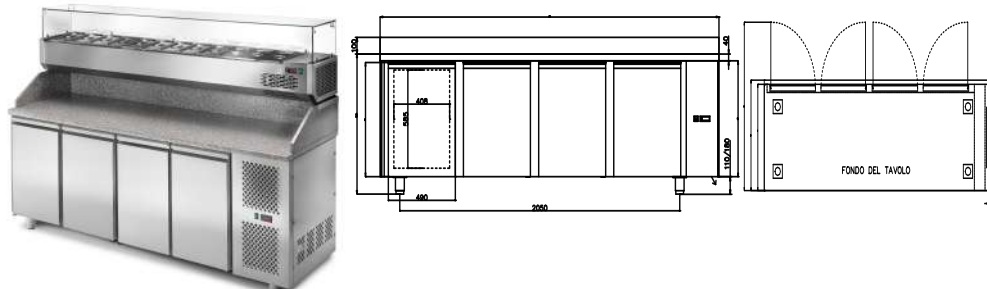

MODEL: 1FPZA-4D & 1FPZA4D-TOP

DIMENSIONS: 2710Wx800Dx1160H

OUTPUT: 380W

WEIGHT: 357 kg

- Refrigerated unit for food-safe polypropylene containers 600 x 400 mm; Net Capacity 576L Depth 800 mm; Temperature 0/+10 C:- The Pizza counter can be paired with chilled display cases with independent unit;- Granite counter top and insulated undercounter. 2 x 10 Amp Plugs

2 YEAR WARRANTY
(2 YEAR PARTS & 1 YEAR LABOUR)

Made in Italy



Please refer to the Spare Parts and Accessories booklet to see all the available optional extras. "Product" dimensions are given in mm and are approximate. Pictures are for illustrative purposes only. Given information may change without notice. For further information on any line drawings or missing product information, please call our head office on 03 9551 3034. All prices exclude GST. Freight charges apply.

SINGLE DOOR NOODLE BAR

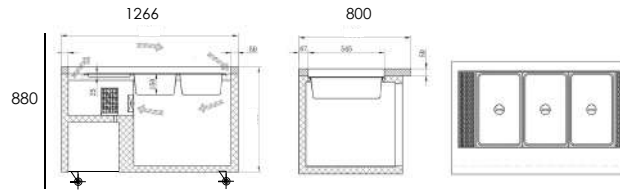
**MODEL:** 270N-B**DIMENSIONS:** 1266Wx800Dx880H**OUTPUT:** 330W**WEIGHT:** 130 kg

- 270 litre capacity - Self closing swing doors - Frost free - Auto defrost - Side mounted motor
 - Adjustable shelves fit GN trays - Ventilated cooling system - Digital temperature control - On castors - R134a refrigerant - Temperature range: 2°C to 8°C - Ambient temperature: 32°C - 240V 10A 50Hz - GN pans not included

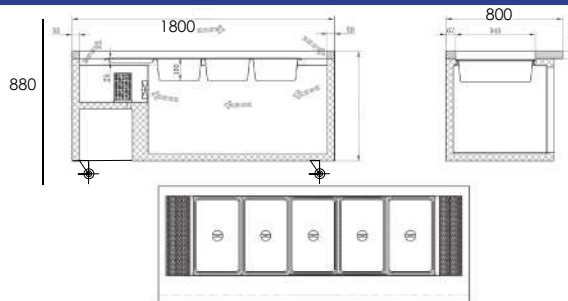

TWO DOOR NOODLE BAR

**MODEL:** 480N-B**DIMENSIONS:** 1800Wx800Dx880H**OUTPUT:** 495W**WEIGHT:** 186 kg

- 477 litre capacity - Self closing swing doors - Frost free - Auto defrost - Side mounted motor -
 Adjustable shelves fit GN trays - Ventilated cooling system - Digital temperature control - On castors - R134a refrigerant - Temperature range: 2°C to 8°C - Ambient temperature: 32°C - 240V 10A 50Hz - GN pans not included

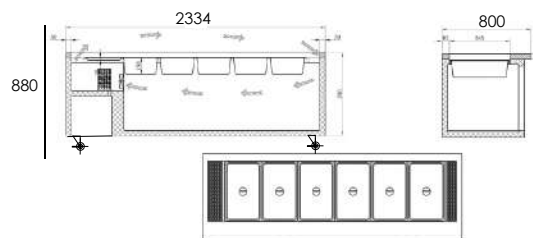

THREE DOOR NOODLE BAR

**MODEL:** 700N-B**DIMENSIONS:** 2334Wx800Dx880H**OUTPUT:** 619W**WEIGHT:** 200 kg

- 684 litre capacity - Self closing swing doors - Frost free - Auto defrost - Side mounted motor
 - Adjustable shelves fit GN trays - Ventilated cooling system - Digital temperature control - On castors - R134a refrigerant - Temperature range: 2°C to 8°C - Ambient temperature: 32°C - 240V 10A 50Hz - GN pans not included



SINGLE DOOR SANDWICH BAR

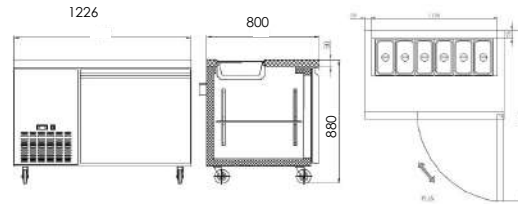

MODEL: 270-S

DIMENSIONS: 1266Wx800Dx880H

OUTPUT: 330W

WEIGHT: 130 kg

- 270 litre capacity - Suits GN food pans - Self closing swing doors - Frost free - Auto defrost - Side mounted motor - Adjustable shelves fit GN trays - Ventilated cooling system - Digital temperature control - On castors - R134a refrigerant - Temperature range: 2°C to 8°C - Ambient temperature: 32°C - 240V 10A 50Hz - GN pans not included



TWO DOOR SANDWICH BAR

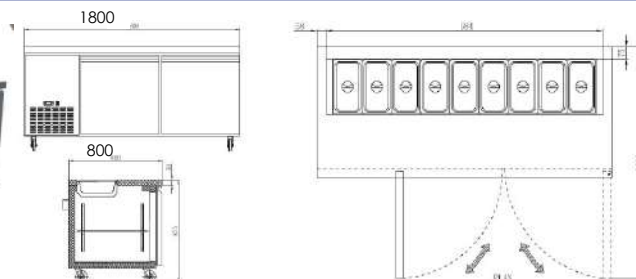

MODEL: 480-S

DIMENSIONS: 1800Wx800Dx880H

OUTPUT: 495W

WEIGHT: 186 kg

- 477 litre capacity - Suits GN food pans - Self closing swing doors - Frost free - Auto defrost - Side mounted motor - Adjustable shelves fit GN trays - Ventilated cooling system - Digital temperature control - On castors - R134a refrigerant - Temperature range: 2°C to 8°C - Ambient temperature: 32°C - 240V 10A 50Hz - GN pans not included



THREE DOOR SANDWICH BAR

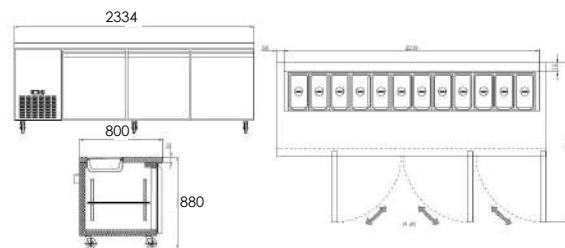

MODEL: 700-S

DIMENSIONS: 2334Wx800Dx880H

OUTPUT: 619W

WEIGHT: 200 kg

- 684 litre capacity - Suits 1/3 GN food pans - Self closing swing doors - Frost free - Auto defrost - Side mounted motor - Adjustable shelves fit GN trays - Ventilated cooling system - Digital temperature control - On castors - R134a refrigerant - Temperature range: 2°C to 8°C - Ambient temperature: 32°C - 240V 10A 50Hz - GN pans not included



HEATED FOOD DISPLAY/ PIE WARMER

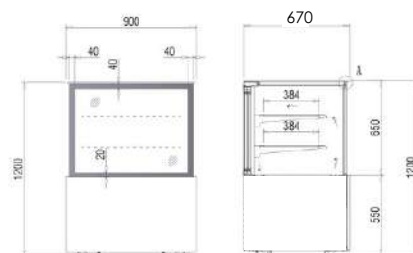

MODEL: PW900

DIMENSIONS: 900Wx670Dx1200H

OUTPUT: 1000W

WEIGHT: 120 kg

900 mm straight glass heated display - 3 shelves + base - Temperature range: 30 C - 80 C - 240V 15A 50HZ - Matches the profile of 3 Tier cake displays.



STRAIGHT GLASS COLD DISPLAY THREE TIER- 900M

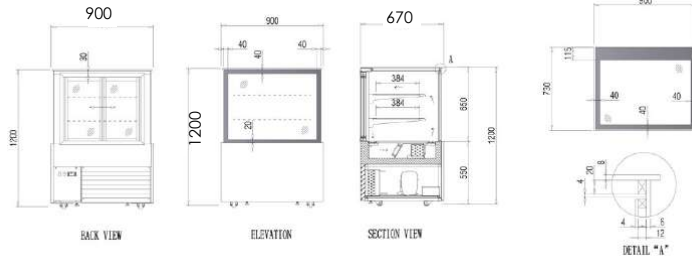

MODEL: SC900B-3S

DIMENSIONS: 900Wx670Dx1200H

OUTPUT: 640W

WEIGHT: 160 kg

- Double glazed and reinforced front glass - Heated front glass - On castors - Digital display with LED lighting - High quality, noiseless centrifugal fan - R134a refrigerant - Temperature range: 2°C - 8°C - Ambient temperature: 35°C - Fully compliant with Australian standards: 240V 10A 50Hz



STRAIGHT GLASS COLD DISPLAY THREE TIER- 1200M

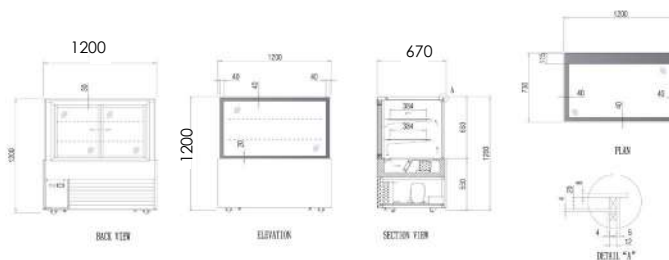

MODEL: SC1200B-3S

DIMENSIONS: 1200Wx670Dx1200H

OUTPUT: 740W

WEIGHT: 200 kg

- Double glazed and reinforced front glass - Heated front glass - On castors - Digital display with LED lighting - High quality, noiseless centrifugal fan - R134a refrigerant - Temperature range: 2°C - 8°C - Ambient temperature: 35°C - Fully compliant with Australian standards: 240V 10A 50Hz



STRAIGHT GLASS COLD DISPLAY THREE TIER- 1500M

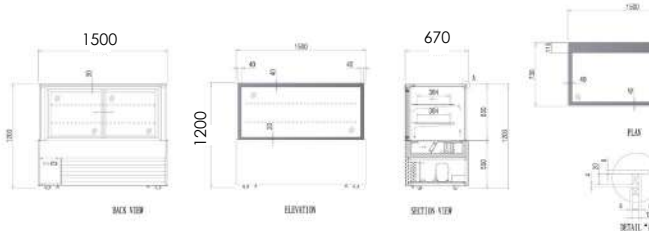

MODEL: SC1500B-3S

DIMENSIONS: 1500Wx670Dx1200H

OUTPUT: 760W

WEIGHT: 250 kg

- Double glazed and reinforced front glass - Heated front glass - On castors - Digital display with LED lighting - High quality, noiseless centrifugal fan - R134a refrigerant - Temperature range: 2°C - 8°C - Ambient temperature: 35°C - Fully compliant with Australian standards: 240V 10A 50Hz



STRAIGHT GLASS COLD DISPLAY THREE TIER- 1800M

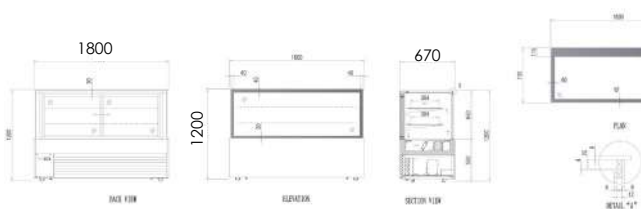

MODEL: SC1800B-3S

DIMENSIONS: 1800Wx670Dx1200H

OUTPUT: 940W

WEIGHT: 300 kg

- Double glazed and reinforced front glass - Heated front glass - On castors - Digital display with LED lighting - High quality, noiseless centrifugal fan - R134a refrigerant - Temperature range: 2°C - 8°C - Ambient temperature: 35°C - Fully compliant with Australian standards: 240V 10A 50Hz



STRAIGHT GLASS COLD DISPLAY FOUR TIER- 900M

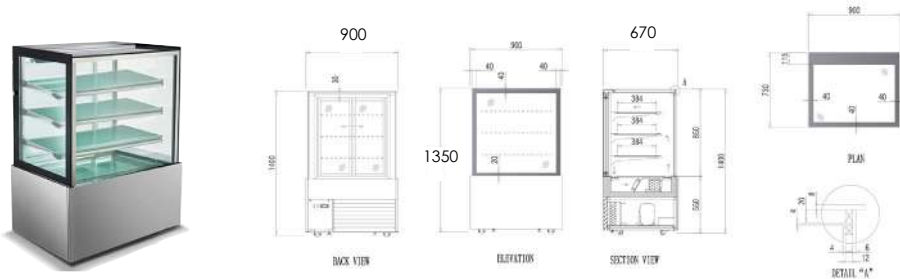

MODEL: SC900B-4S

DIMENSIONS: 900Wx670Dx1350H

OUTPUT: 700W

WEIGHT: 200 kg



- Double glazed and reinforced front glass - Heated front glass - On castors - Digital display with LED lighting - High quality, noiseless centrifugal fan - R134a refrigerant - Temperature range: 2°C - 8°C - Ambient temperature: 35°C - Fully compliant with Australian standards: 240V 10A 50Hz

STRAIGHT GLASS COLD DISPLAY FOUR TIER- 1200M

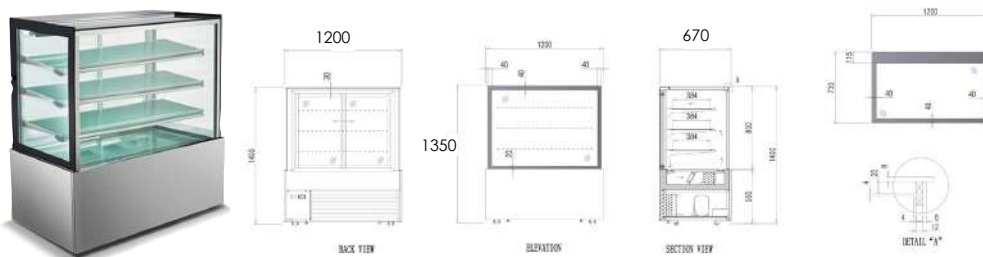

MODEL: SC1200B-4S

DIMENSIONS: 1200Wx670Dx1350H

OUTPUT: 840W

WEIGHT: 240 kg



- Double glazed and reinforced front glass - Heated front glass - On castors - Digital display with LED lighting - High quality, noiseless centrifugal fan - R134a refrigerant - Temperature range: 2°C - 8°C - Ambient temperature: 35°C - Fully compliant with Australian standards: 240V 10A 50Hz

STRAIGHT GLASS COLD DISPLAY FOUR TIER- 1500M

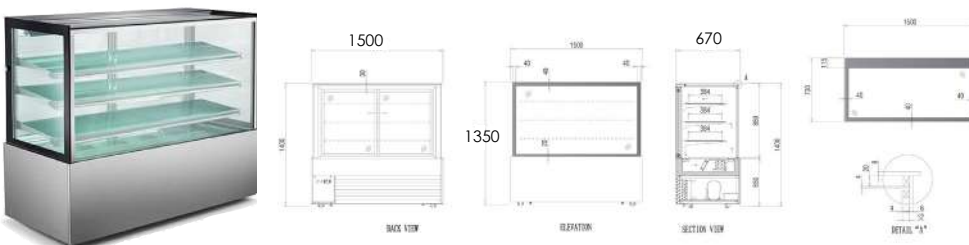

MODEL: SC1500B-4S

DIMENSIONS: 1500Wx670Dx1350H

OUTPUT: 910W

WEIGHT: 300 kg



- Double glazed and reinforced front glass - Heated front glass - On castors - Digital display with LED lighting - High quality, noiseless centrifugal fan - R134a refrigerant - Temperature range: 2°C - 8°C - Ambient temperature: 35°C - Fully compliant with Australian standards: 240V 10A 50Hz

STRAIGHT GLASS COLD DISPLAY FOUR TIER- 1800M

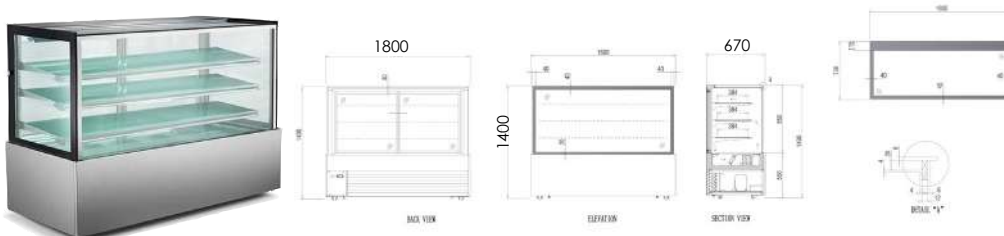

MODEL: SC1800B-4S

DIMENSIONS: 1800Wx670Dx1350H

OUTPUT: 960W

WEIGHT: 350 kg



- Double glazed and reinforced front glass - Heated front glass - On castors - Digital display with LED lighting - High quality, noiseless centrifugal fan - R134a refrigerant - Temperature range: 2°C - 8°C - Ambient temperature: 35°C - Fully compliant with Australian standards: - 240V 10A 50Hz

ONE GLASS SWING DOOR REFRIGERATOR

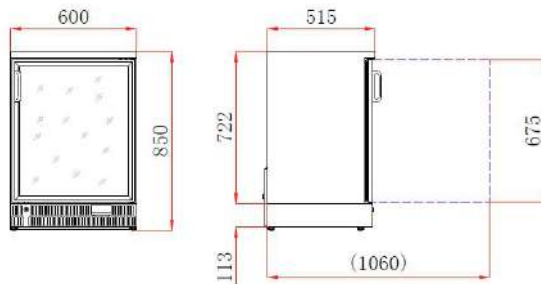

Black painted exterior, compressed aluminium interior -- Toughened glass door -- With light and lock -- Electric Controller With Digital Temperature Display -- Auto Defrosting And Auto Evaporating Of Defrost Water -- Airflow From Down Front Grill In Case The Unit Can Be Used Against Wall -- HC Refrigerant

MODEL: BB1SW

DIMENSIONS: 600Wx515Dx850H

OUTPUT: 0.12 Kw

WEIGHT: 80 Kg



TWO GLASS SWING DOOR REFRIGERATOR

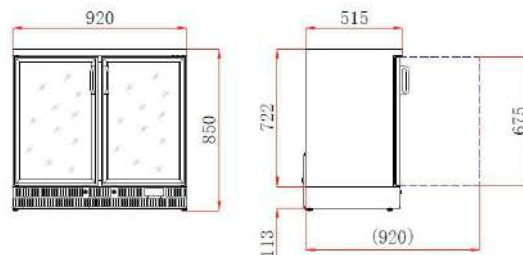

Black painted exterior, compressed aluminium interior -- Sliding door available for 2 door units 2 layers of chromed shelf -- Toughened glass door -- With light and lock -- Electric Controller With Digital Temperature Display -- Auto Defrosting And Auto Evaporating Of Defrost Water -- Airflow From Down Front Grill In Case The Unit Can Be Used Against Wall -- HC Refrigerant

MODEL: BB2SW

DIMENSIONS: 920Wx515Dx850H

OUTPUT: 0.12 Kw

WEIGHT: 92 Kg



TWO GLASS SLIDE DOOR REFRIGERATOR

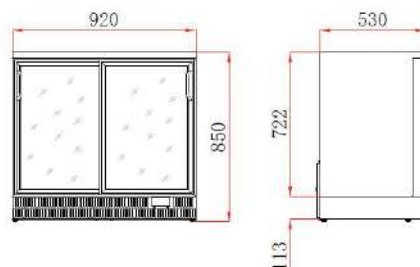

Black painted exterior, compressed aluminium interior -- Sliding door available for 3 door units 2 layers of chromed shelf -- Toughened glass door -- With light and lock -- Electric Controller With Digital Temperature Display -- Auto Defrosting And Auto Evaporating Of Defrost Water -- Airflow From Down Front Grill In Case The Unit Can Be Used Against Wall -- HC Refrigerant

MODEL: BB2SL

DIMENSIONS: 920Wx515Dx850H

OUTPUT: 0.12 Kw

WEIGHT: 92 Kg



THREE GLASS SWING DOOR REFRIGERATOR

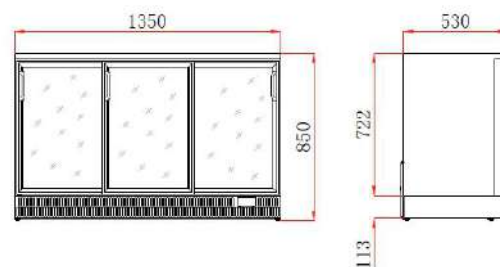

Black painted exterior, compressed aluminium interior -- Sliding door available for 3 door units 2 layers of chromed shelf -- Toughened glass door -- With light and lock -- Electric Controller With Digital Temperature Display -- Auto Defrosting And Auto Evaporating Of Defrost Water -- Airflow From Down Front Grill In Case The Unit Can Be Used Against Wall -- HC Refrigerant

MODEL: BB3SW

DIMENSIONS: 1350Wx530Dx850H

OUTPUT: 0.14Kw

WEIGHT: 123 Kg



THREE GLASS SLIDE DOOR REFRIGERATOR

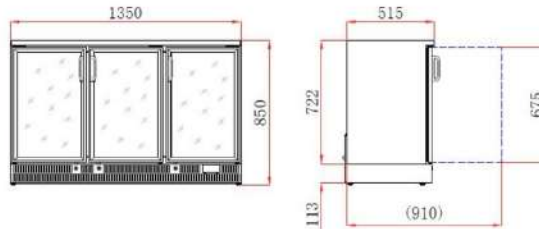

MODEL: BB3SL

DIMENSIONS: 1350Wx530Dx850H

OUTPUT: 0.14Kw

WEIGHT: 123 Kg

Black painted exterior, compressed aluminium interior -- Sliding door - 3 door units
 2 layers of chromed shelf -- Toughened glass door -- With light and lock -- Electric Controller With Digital Temperature Display -- Auto Defrosting And Auto Evaporating Of Defrost Water -- Airflow From Down Front Grill In Case The Unit Can Be Used Against Wall -- HC Refrigerant



MITCHEL ACCESSORIES



-Glass doors to suit UB320R, UB500-R, UB645-R

MODEL: GLASS DOORS

DIMENSIONS: 455Wx50Dx670H



-LED lights to suit UB320-R, UB500-R, UB645-R

MODEL: LED LIGHTS

DIMENSIONS: 750Wx20Dx20H

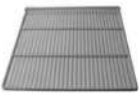

-Shelves to suit gn or GLA series refrigerators and freezers

MODEL: SHELF

DIMENSIONS: NA



-Shelves to suit gn or GLA series refrigerators and freezers

MODEL: SHELF RUNNERS

DIMENSIONS: NA



COMMERCIAL



COMMERCIAL

STAINLESS STEEL PRODUCTS

Stainless Steel Overbench Shelving

Stainless Steel Benching

Stainless Steel Benching with Polyurethane

Chopping Board Top

Stainless Steel Sinks

Dishwasher Inlet & Outlet Benches

Stainless Steel Wall Shelving

Stainless Steel Racks & Drawers

Trolleys

Gastronorm Food Pans



SINGLE TIER OVERBENCH SHELF 1500MM

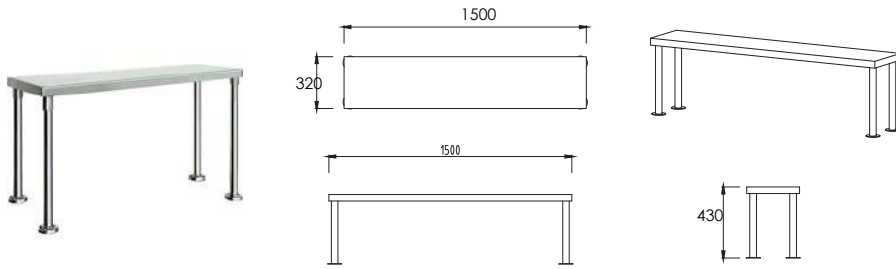

MODEL: 00-1500L

DIMENSIONS: 1500Wx320Dx430H

WEIGHT: 8.5 kg

OUTPUT: N/A

- 1500mm wide - 1.2mm thick stainless steel - 80mm stainless steel feet - 304 grade stainless steel - Easy to assemble

SINGLE TIER OVERBENCH SHELF 1800MM

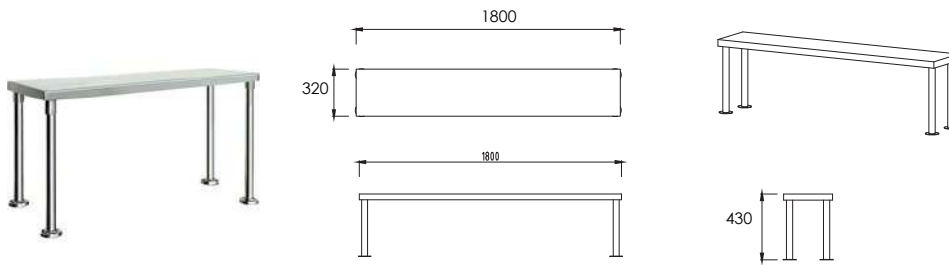

MODEL: 00-1800L

DIMENSIONS: 1800Wx320Dx430H

WEIGHT: 10 kg

OUTPUT: N/A

- 1800mm wide - 1.2mm thick stainless steel - 80mm stainless steel feet - 304 grade stainless steel - Easy to assemble

DOUBLE TIER OVERBENCH SHELF 1500MM

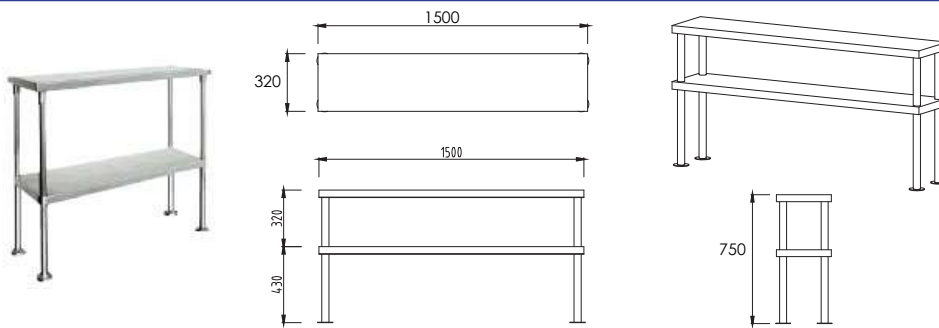

MODEL: 01-1500L

DIMENSIONS: 1500Wx320Dx750H

WEIGHT: 15 kg

OUTPUT: N/A

- 1500mm wide - 1.2mm thick stainless steel - 80mm stainless steel feet - Fully adjustable middle shelf - 304 grade stainless steel - Easy to assemble

DOUBLE TIER OVERBENCH SHELF 1800MM

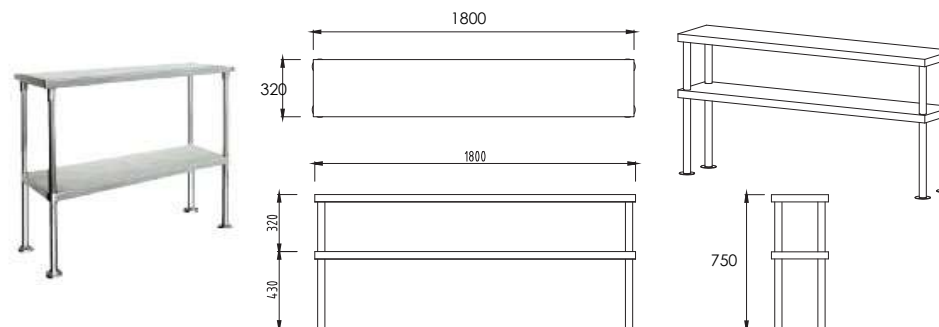

MODEL: 01-1800L

DIMENSIONS: 1800Wx320Dx750H

WEIGHT: 18 kg

OUTPUT: N/A

- 1800mm wide - 1.2mm thick stainless steel - 80mm stainless steel feet - Fully adjustable middle shelf - 304 grade stainless steel - Easy to assemble

BENCH WITH STORAGE SHELF UNDERNEATH 900MM

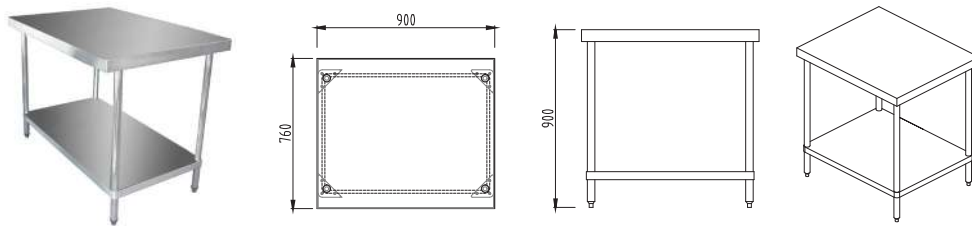

MODEL: 02-900L

DIMENSIONS: 900Wx760Dx900H

WEIGHT: 30 kg

OUTPUT: N/A

- 900mm wide - Ø38mm satin polished stainless steel round legs - 2mm galvanised carbon steel reinforced backing - Adjustable feet and shelves - Easy to assemble - Castors available as an optional extra

BENCH WITH STORAGE SHELF UNDERNEATH 1200MM

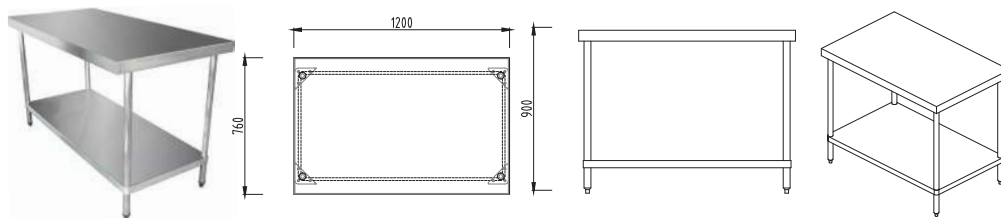

MODEL: 02-1200L

DIMENSIONS: 1200Wx760Dx900H

WEIGHT: 40 kg

OUTPUT: N/A

- 1200mm wide - Ø38mm satin polished stainless steel round legs - 2mm galvanised carbon steel reinforced backing - Adjustable feet and shelves - Easy to assemble - Castors available as an optional extra

BENCH WITH STORAGE SHELF UNDERNEATH 1500MM

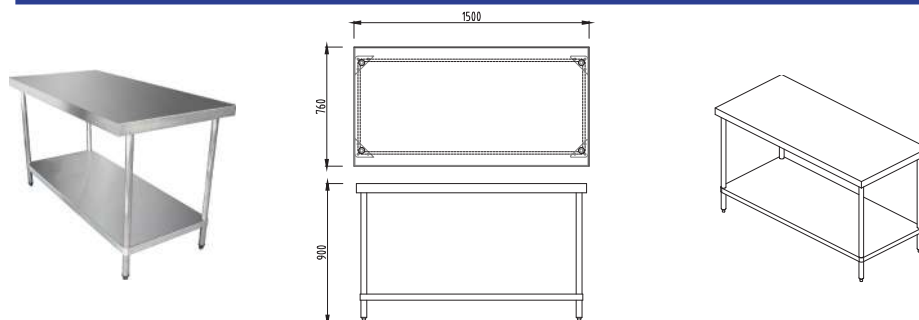

MODEL: 02-1500L

DIMENSIONS: 1500Wx760Dx900H

WEIGHT: 50 kg

OUTPUT: N/A

- 1500mm wide - Ø38mm satin polished stainless steel round legs - 2mm galvanised carbon steel reinforced backing - Adjustable feet and shelves - Easy to assemble - Castors available as an optional extra

BENCH WITH STORAGE SHELF UNDERNEATH 1800MM

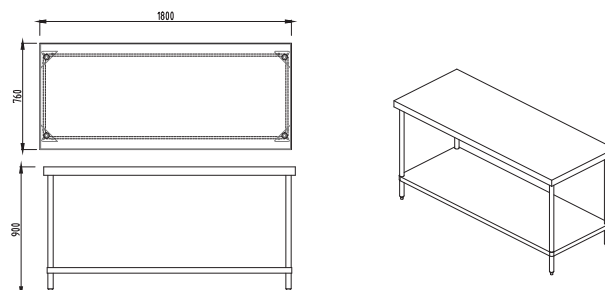

MODEL: 02-1800L

DIMENSIONS: 1800Wx760Dx900H

WEIGHT: 70 kg

OUTPUT: N/A

- 1800mm wide - Ø38mm satin polished stainless steel round legs - 2mm galvanised carbon steel reinforced backing - Adjustable feet and shelves - Easy to assemble - Castors available as an optional extra

BENCH WITH STORAGE SHELF UNDERNEATH 2400MM

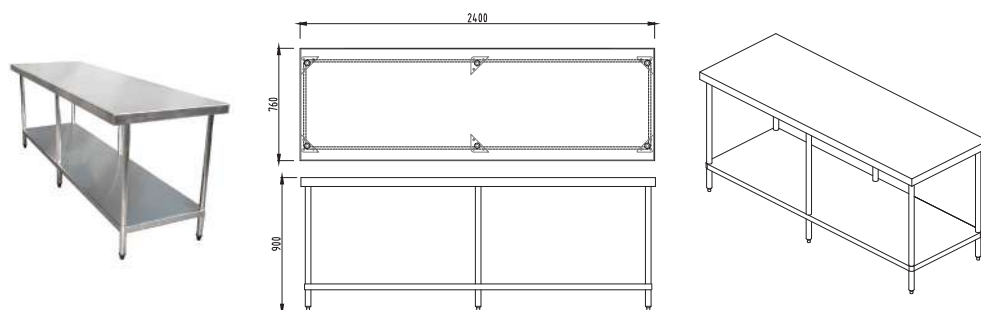

MODEL: 02-2400L

DIMENSIONS: 2400Wx760Dx900H

WEIGHT: 90 kg

OUTPUT: N/A

- 900mm wide - Ø38mm satin polished stainless steel round legs - 2mm galvanised carbon steel reinforced backing - Adjustable feet and shelves - Easy to assemble - Castors available as an optional extra

BENCH WITH STORAGE SHELF UNDERNEATH AND SPLASHBACK 300MM

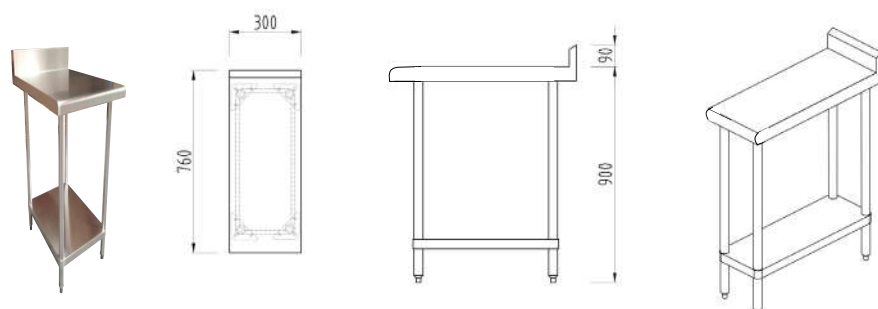

MODEL: 03-300L

DIMENSIONS: 300Wx760Dx900H

WEIGHT: 13 kg

OUTPUT: N/A

- 300mm wide - 90mm angled top splash back - Ø38mm satin polished stainless steel round legs - 2mm galvanised carbon steel reinforced backing - Adjustable feet and shelves - Easy to assemble - Castors available as an optional extra - To match oxford cooking equipment range.

BENCH WITH STORAGE SHELF UNDERNEATH AND SPLASHBACK 450MM

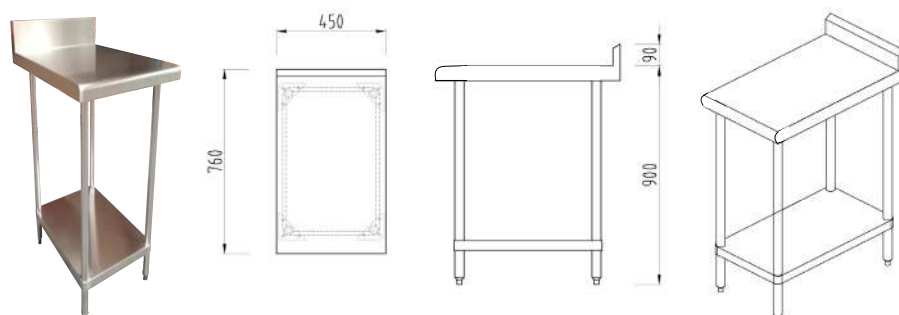

MODEL: 03-450L

DIMENSIONS: 450Wx760Dx900H

WEIGHT: 20 kg

OUTPUT: N/A

- 450mm wide - 90mm angled top splash back - Ø38mm satin polished stainless steel round legs - 2mm galvanised carbon steel reinforced backing - Adjustable feet and shelves - Easy to assemble - Castors available as an optional extra. -To match oxford cooking equipment range.

BENCH WITH STORAGE SHELF UNDERNEATH AND SPLASHBACK 600MM

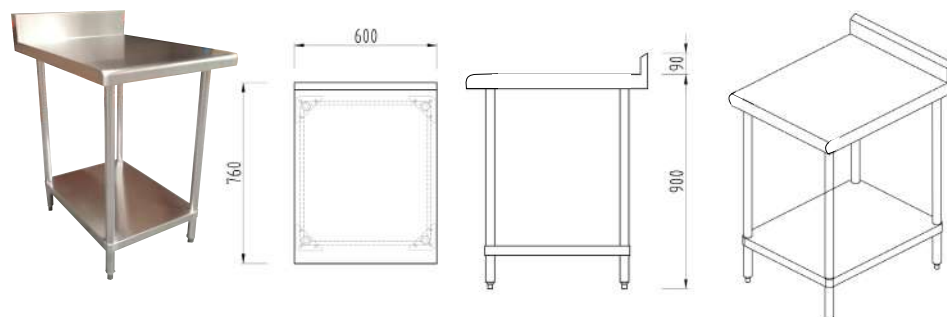

MODEL: 03-600L

DIMENSIONS: 600Wx760Dx900H

WEIGHT: 25 kg

OUTPUT: N/A

- 600mm wide - 90mm angled top splash back - Ø38mm satin polished stainless steel round legs - 2mm galvanised carbon steel reinforced backing - Adjustable feet and shelves - Easy to assemble - Castors available as an optional extra. To match oxford cooking equipment range.

BENCH WITH STORAGE SHELF UNDERNEATH 900MM

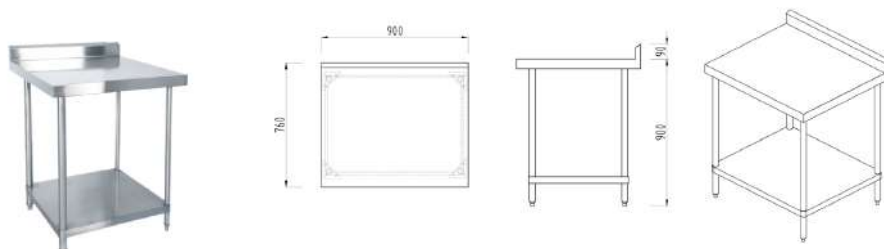

MODEL: 03-900L

DIMENSIONS: 900Wx760Dx900H

WEIGHT: 35 kg

- 900mm wide - 90mm angled top splash back - Ø38mm satin polished stainless steel round legs - 2mm galvanised carbon steel reinforced backing - Adjustable feet and shelves - Easy to assemble - Castors available as an optional extra

BENCH WITH STORAGE SHELF UNDERNEATH 1200MM

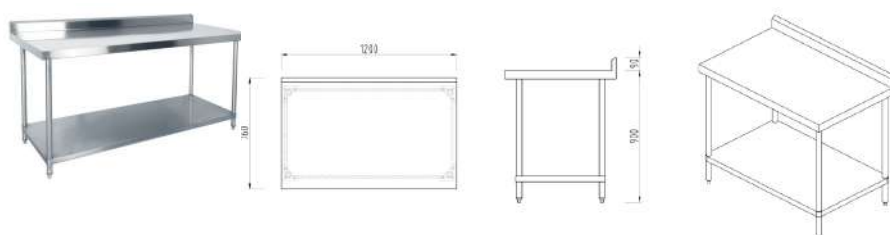

MODEL: 03-1200L

DIMENSIONS: 1200Wx760Dx900H

WEIGHT: 50 kg

- 1200mm wide - 90mm angled top splash back - Ø38mm satin polished stainless steel round legs - 2mm galvanised carbon steel reinforced backing - Adjustable feet and shelves - Easy to assemble - Castors available as an optional extra

BENCH WITH STORAGE SHELF UNDERNEATH 1500MM

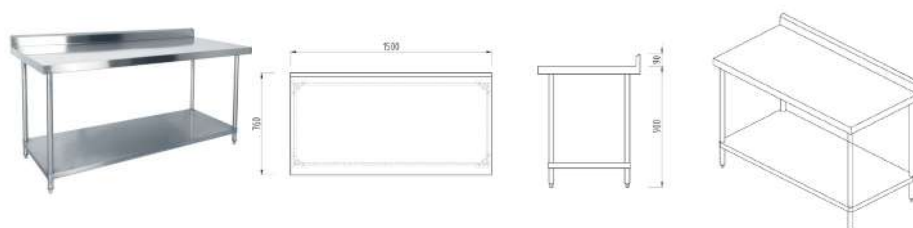

MODEL: 03-1500L

DIMENSIONS: 1500Wx760Dx900H

WEIGHT: 65 kg

- 1500mm wide - 90mm angled top splash back - Ø38mm satin polished stainless steel round legs - 2mm galvanised carbon steel reinforced backing - Adjustable feet and shelves - Easy to assemble - Castors available as an optional extra

BENCH WITH STORAGE SHELF UNDERNEATH 1800MM

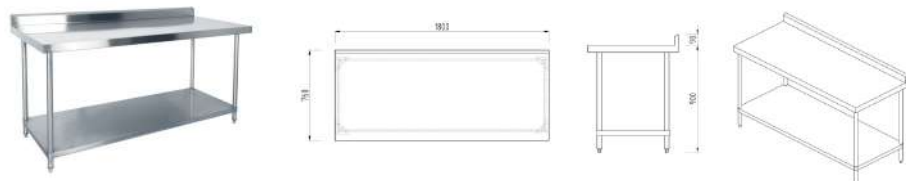

MODEL: 03-1800L

DIMENSIONS: 1800Wx760Dx900H

WEIGHT: 85 kg

- 1800mm wide - 90mm angled top splash back - Ø38mm satin polished stainless steel round legs - 2mm galvanised carbon steel reinforced backing - Adjustable feet and shelves - Easy to assemble - Castors available as an optional extra

BENCH WITH STORAGE SHELF UNDERNEATH AND SPLASHBACK 2400MM

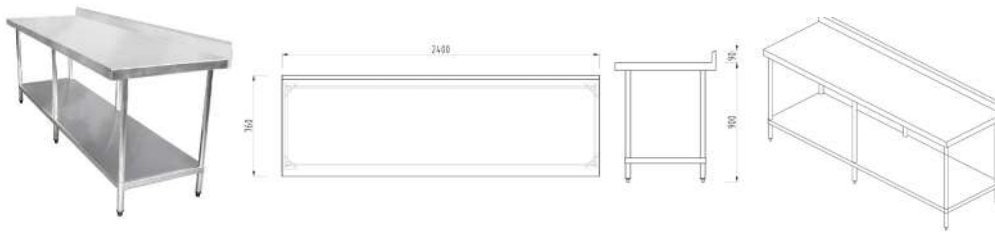

MODEL: 03-2400L

DIMENSIONS: 2400Wx760Dx900H

WEIGHT: 98 kg

- 2400mm wide - 90mm angled top splash back - Ø38mm satin polished stainless steel round legs - 2mm galvanised carbon steel reinforced backing - Adjustable feet and shelves - Easy to assemble - Castors available as an optional extra

KSS

Kitchen Stainless Steel

CORNER BENCH WITH STORAGE SHELF UNDERNEATH AND SPLASHBACK

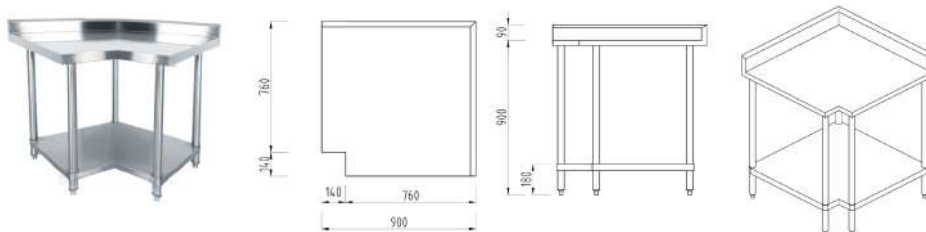

MODEL: 05-900L

DIMENSIONS: 900Wx760Dx900H

WEIGHT: 65 kg

- 900mm wide on each side - 90mm angled top splash back - Ø38mm satin polished stainless steel round legs - 2mm galvanised carbon steel reinforced backing - Adjustable feet and shelves - Easy to assemble

KSS

Kitchen Stainless Steel

SINGLE SINK WITH SPLASHBACK AND ADJUSTABLE POT RACK 600MM

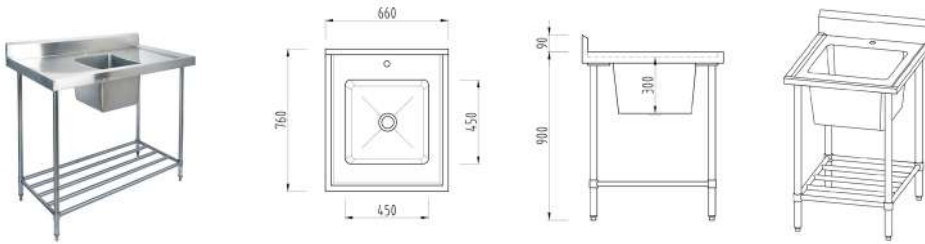

MODEL: 06-600L

DIMENSIONS: 600Wx760Dx900H

WEIGHT: 15 kg

- 600mm wide - 90mm angled top splash back - Sink size: 450Wx450Dx300H - 32mm tap hole - 90mm waste hole - Ø38mm satin polished stainless steel round legs - 2mm galvanised carbon steel reinforced backing - Adjustable feet - Easy to assemble



SINGLE SINK WITH SPLASHBACK AND ADJUSTABLE POT RACK 1200MM

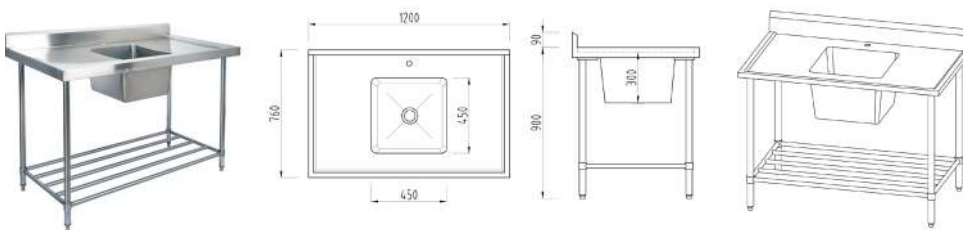

MODEL: 06-1200L

DIMENSIONS: 1200Wx760Dx900H

WEIGHT: 30 kg

- 1200mm wide - 90mm angled top splash back - Sink size: 450Wx450Dx300H - 32mm tap hole - 90mm waste hole - Ø38mm satin polished stainless steel round legs - 2mm galvanised carbon steel reinforced backing - Adjustable feet - Easy to assemble



SINGLE SINK WITH SPLASHBACK AND ADJUSTABLE POT RACK 1500MM

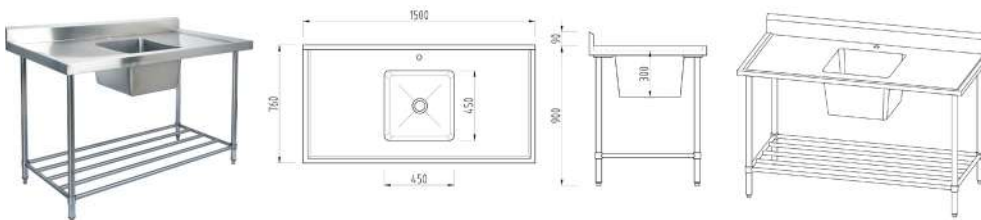

MODEL: 06-1500L

DIMENSIONS: 1500Wx760Dx900H

WEIGHT: 35 kg

- 1500mm wide - 90mm angled top splash back - Sink size: 450Wx450Dx300H - 32mm tap hole - 90mm waste hole - Ø38mm satin polished stainless steel round legs - 2mm galvanised carbon steel reinforced backing - Adjustable feet - Easy to assemble



SINGLE SINK WITH SPLASHBACK AND ADJUSTABLE POT RACK 1800MM

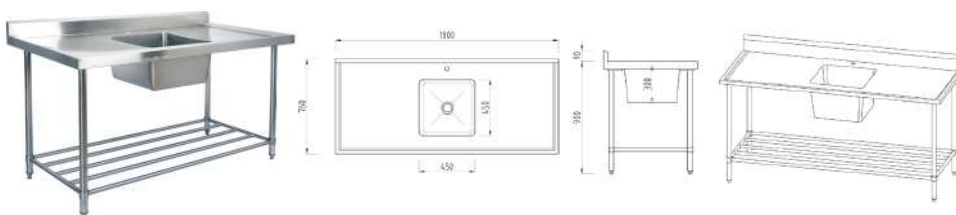

MODEL: 06-1800L

DIMENSIONS: 1800Wx760Dx900H

WEIGHT: 45 kg

- 1800mm wide - 90mm angled top splash back - Sink size: 450Wx450Dx300H - 32mm tap hole - 90mm waste hole - Ø38mm satin polished stainless steel round legs - 2mm galvanised carbon steel reinforced backing - Adjustable feet - Easy to assemble



DOUBLE SINK WITH SPLASHBACK AND ADJUSTABLE POT RACK 1200MM

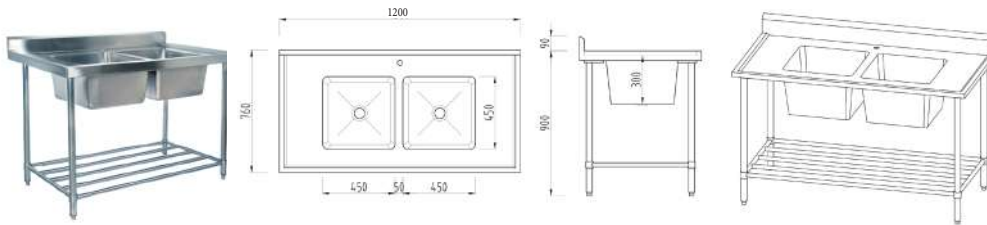

MODEL: 07-1200L

DIMENSIONS: 1200Wx760Dx900H

WEIGHT: 31 kg

- 1200mm wide - 90mm angled top splash back - Sink size: 450Wx450Dx300H - 32mm tap hole - 90mm waste hole - Ø38mm satin polished stainless steel round legs - 2mm galvanised carbon steel reinforced backing - Adjustable feet - Easy to assemble



DOUBLE SINK WITH SPLASHBACK AND ADJUSTABLE POT RACK 1500MM

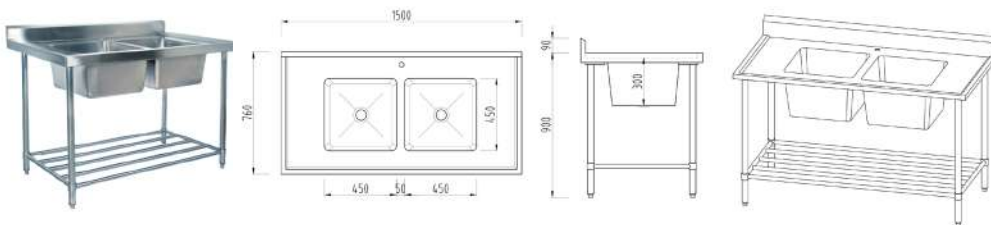

MODEL: 07-1500L

DIMENSIONS: 1500Wx760Dx900H

WEIGHT: 38 kg

- 1500mm wide - 90mm angled top splash back - Sink size: 450Wx450Dx300H - 32mm tap hole - 90mm waste hole - Ø38mm satin polished stainless steel round legs - 2mm galvanised carbon steel reinforced backing - Adjustable feet - Easy to assemble



DOUBLE SINK WITH SPLASHBACK AND ADJUSTABLE POT RACK 1800MM

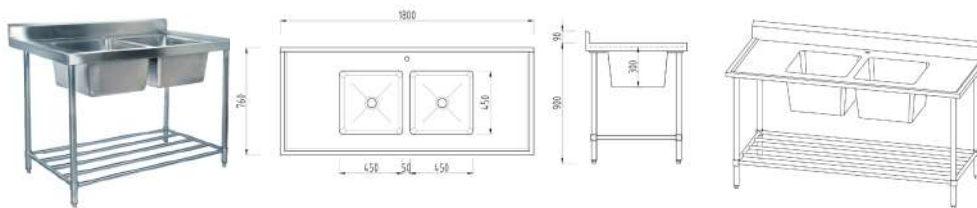

MODEL: 07-1800L

DIMENSIONS: 1800Wx760Dx900H

WEIGHT: 45 kg

- 1800mm wide - 90mm angled top splash back - Sink size: 450Wx450Dx300H - 32mm tap hole - 90mm waste hole - Ø38mm satin polished stainless steel round legs - 2mm galvanised carbon steel reinforced backing - Adjustable feet - Easy to assemble



DOUBLE SINK WITH SPLASHBACK AND ADJUSTABLE POT RACK 2400MM

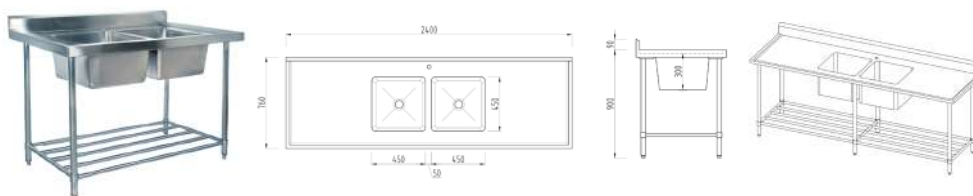

MODEL: 07-2400L

DIMENSIONS: 2400Wx760Dx900H

WEIGHT: 52 kg

- 2400mm wide - 90mm angled top splash back - Sink size: 450Wx450Dx300H - 32mm tap hole - 90mm waste hole - Ø38mm satin polished stainless steel round legs - 2mm galvanised carbon steel reinforced backing - Adjustable feet - Easy to assemble



DISHWASHER OUTLET BENCH LEFT 750MM

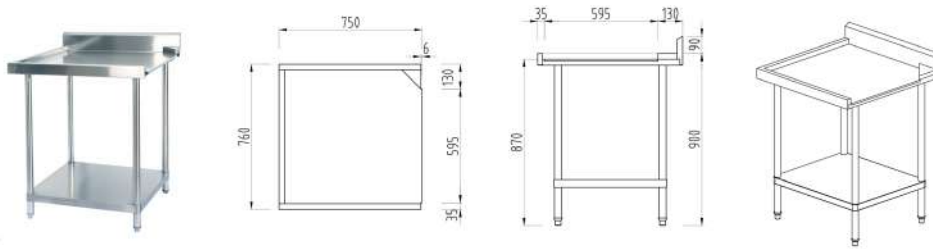

MODEL: 12L D/W

DIMENSIONS: 750Wx760Dx900H

WEIGHT: 40 kg

- 750mm wide - 90mm angled top splash back - Designed to fit in on the left hand side of dishwasher - Ø38mm satin polished stainless steel round legs - Compatible with most commercial dishwashers - 2mm galvanised carbon steel reinforced backing - Adjustable feet - Easy to assemble



DISHWASHER OUTLET BENCH RIGHT 750MM

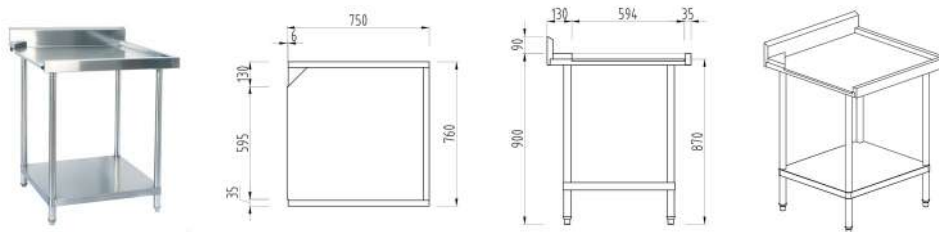

MODEL: 12-R D/W

DIMENSIONS: 750Wx760Dx900H

WEIGHT: 40 kg

- 750mm wide - 90mm angled top splash back - Designed to fit in on the right hand side of dishwasher - Ø38mm satin polished stainless steel round legs - Compatible with most commercial dishwashers - 2mm galvanised carbon steel reinforced backing - Adjustable feet - Easy to assemble



DISHWASHER INLET BENCH LEFT 1500MM

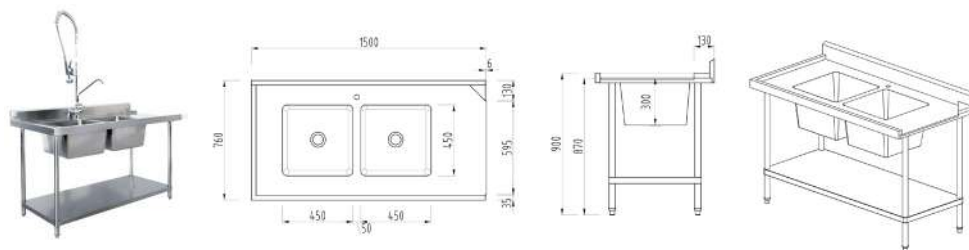

MODEL: 13-L D/W

DIMENSIONS: 1500Wx760Dx900H

WEIGHT: 70 kg

- 1500mm wide - 90mm angled top splash back - Designed to fit in on the left hand side of dishwasher - Ø38mm satin polished stainless steel round legs - 90mm waste hole - Compatible with most commercial dishwashers - 2mm galvanised carbon steel reinforced backing - Adjustable feet - Easy to assemble. Note : Taps shown in Image are charges saperately



DISHWASHER INLET BENCH RIGHT 1500MM

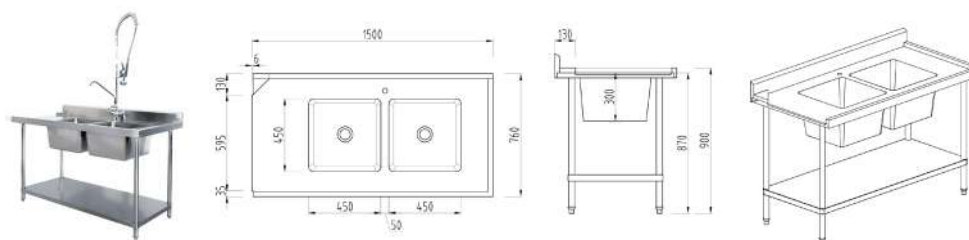

MODEL: 13-R D/W

DIMENSIONS: 1500Wx760Dx900H

WEIGHT: 70 kg

- 1500mm wide - 90mm angled top splash back - Designed to fit in on the left hand side of dishwasher - Ø38mm satin polished stainless steel round legs - 90mm waste hole - Compatible with most commercial dishwashers - 2mm galvanised carbon steel reinforced backing - Adjustable feet - Easy to assemble. Note : Taps shown in Image are charges saperately



BENCH WITH ADJUSTABLE STORAGE SHELF UNDERNEATH 900MM

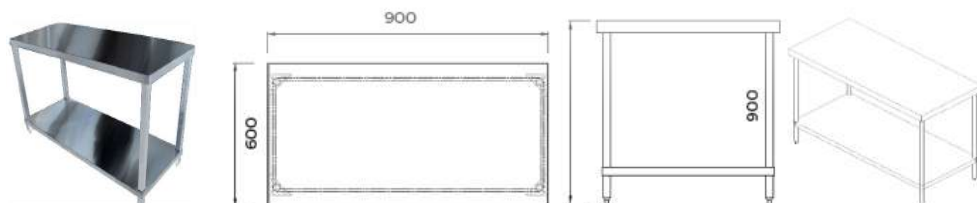

MODEL: 02-6-900L

DIMENSIONS: 900Wx600Dx900H

WEIGHT: 30 kg

- 38mm square tubes - adjustable feet - simple assembly - heavy duty construction
Castors available as an optional extra



BENCH WITH ADJUSTABLE STORAGE SHELF UNDERNEATH 1200MM

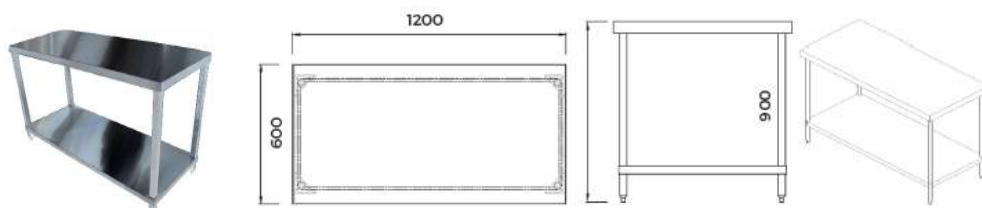

MODEL: 02-6-1200L

DIMENSIONS: 1200Wx600Dx900H

WEIGHT: 40 kg

- 38mm square tubes - adjustable feet - simple assembly - heavy duty construction
Castors available as an optional extra



BENCH WITH ADJUSTABLE STORAGE SHELF UNDERNEATH 1500MM

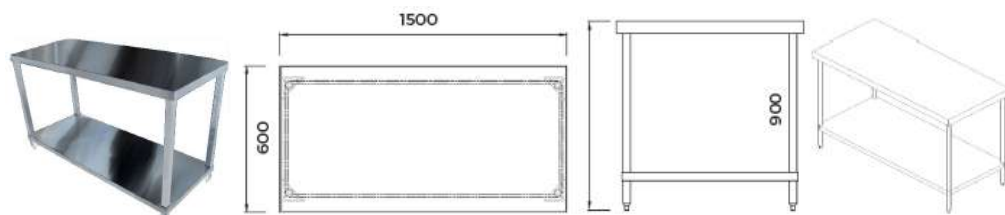

MODEL: 02-6-1500L

DIMENSIONS: 1500Wx600Dx900H

WEIGHT: 50 kg

- 38mm square tubes - adjustable feet - simple assembly - heavy duty construction
Castors available as an optional extra



BENCH WITH ADJUSTABLE STORAGE SHELF UNDERNEATH 1800MM

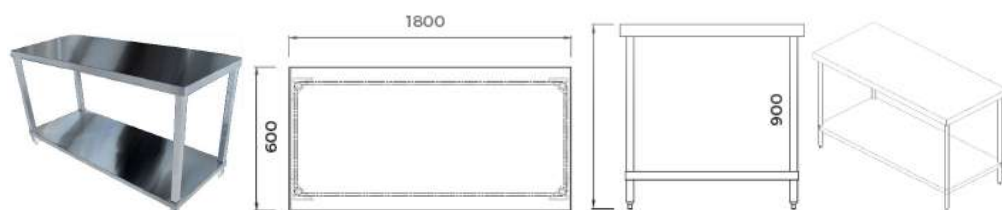

MODEL: 02-6-1800L

DIMENSIONS: 1800Wx600Dx900H

WEIGHT: 70 kg

- 38mm square tubes - adjustable feet - simple assembly - heavy duty construction
Castors available as an optional extra



BENCH WITH ADJUSTABLE STORAGE SHELF UNDERNEATH 2400MM

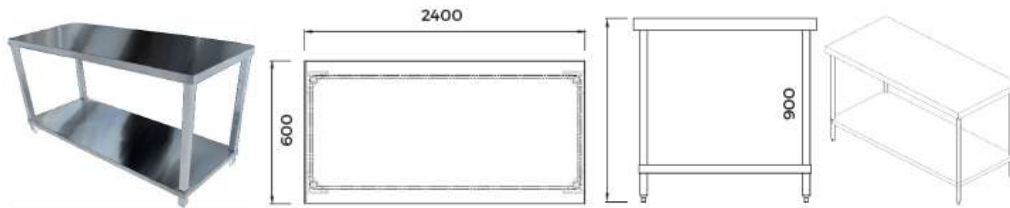

MODEL: 02-6-2400L

DIMENSIONS: 2400Wx600Dx900H

WEIGHT: 90 kg

- 38mm square tubes - adjustable feet - simple assembly - heavy duty construction
 Castors available as an optional extra



BENCH WITH ADJUSTABLE STORAGE SHELF UNDERNEATH AND SPLASH BACK 900MM

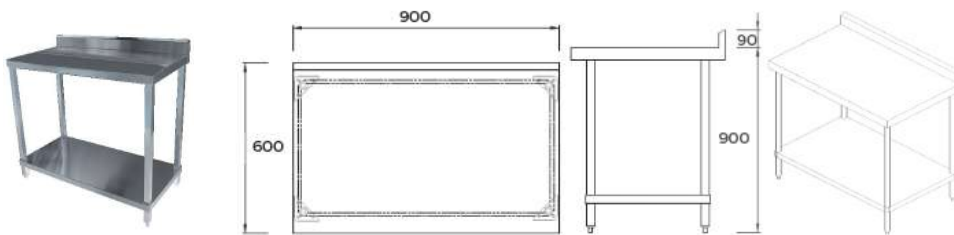

MODEL: 03-6-900L

DIMENSIONS: 900Wx600Dx900H

WEIGHT: 35 kg

90mm angled top splashback, 38mm square tubes, adjustable feet, simple assembly, heavy duty construction.

Castors available as an optional extra



BENCH WITH ADJUSTABLE STORAGE SHELF UNDERNEATH AND SPLASH BACK 1200MM

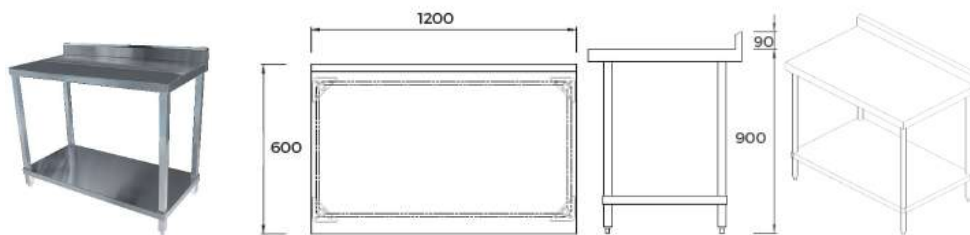

MODEL: 03-6-1200L

DIMENSIONS: 1200Wx600Dx900H

WEIGHT: 50 kg

90mm angled top splashback, 38mm square tubes, adjustable feet, simple assembly, heavy duty construction.

Castors available as an optional extra



BENCH WITH ADJUSTABLE STORAGE SHELF UNDERNEATH AND SPLASH BACK 1500MM

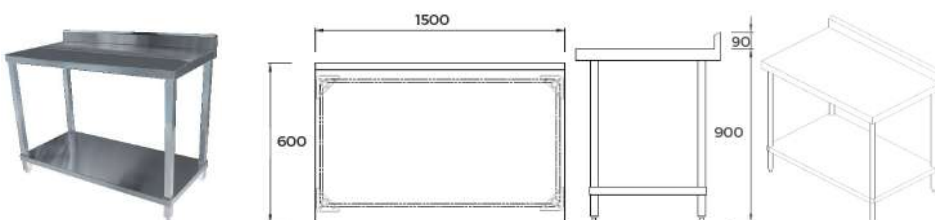

MODEL: 03-6-1500L

DIMENSIONS: 1500Wx600Dx900H

WEIGHT: 65 kg

90mm angled top splashback, 38mm square tubes, adjustable feet, simple assembly, heavy duty construction.

Castors available as an optional extra



Please refer to the Spare Parts and Accessories booklet to see all the available optional extras. "Product" dimensions are given in mm and are approximate. Pictures are for illustrative purposes only. Given information may change without notice. For further information on any line drawings or missing product information, please call our head office on 03 9551 3034. All prices exclude GST. Freight charges apply.

BENCH WITH ADJUSTABLE STORAGE SHELF UNDERNEATH AND SPLASH BACK 1800MM

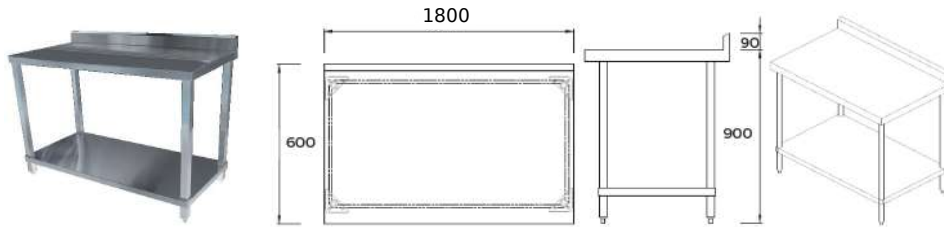

MODEL: 03-6-1800L

DIMENSIONS: 1800Wx600Dx900H

WEIGHT: 85 kg

90mm angled top splashback, 38mm square tubes, adjustable feet, simple assembly, heavy duty construction.

Castors available as an optional extra



BENCH WITH ADJUSTABLE STORAGE SHELF UNDERNEATH AND SPLASH BACK 2400MM

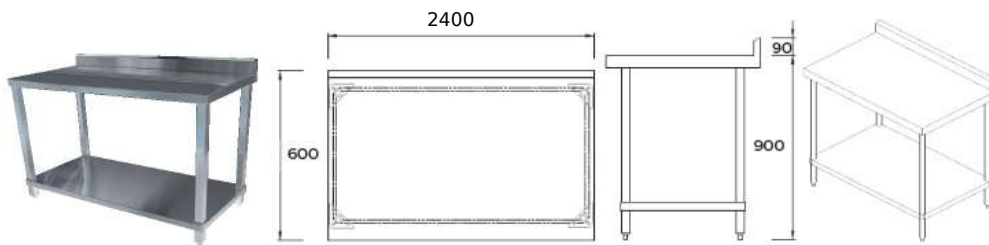

MODEL: 03-6-2400L

DIMENSIONS: 2400Wx600Dx900H

WEIGHT: 98 kg

90mm angled top splashback, 38mm square tubes, adjustable feet, simple assembly, heavy duty construction.

Castors available as an optional extra



SINGLE SINK WITH SPLASHBACK AND ADJUSTABLE POT RACK 900MM

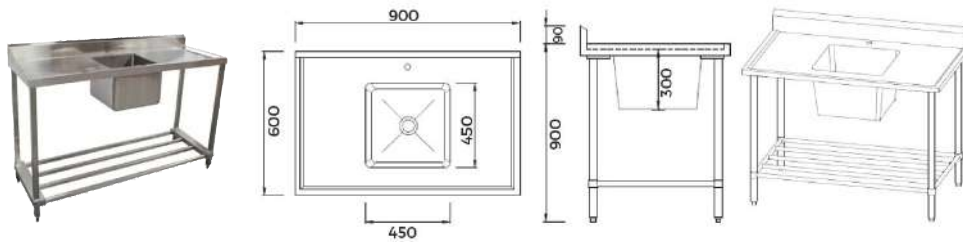

MODEL: 06-6-900L

DIMENSIONS: 900Wx600Dx900H

WEIGHT: 20 kg

- 38mm square tubes - adjustable feet - simple assembly - heavy duty construction - Sink size 450W x 450D x 300H - 32mm tap hole - 90mm waste hole



SINGLE SINK WITH SPLASHBACK AND ADJUSTABLE POT RACK 1200MM

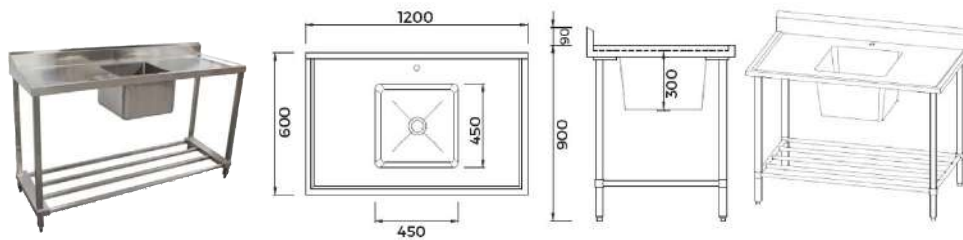

MODEL: 06-6-1200L

DIMENSIONS: 1200Wx600Dx900H

WEIGHT: 30 kg

- 38mm square tubes - adjustable feet - simple assembly - heavy duty construction - Sink size 450W x 450D x 300H - 32mm tap hole - 90mm waste hole



SINGLE SINK WITH SPLASHBACK AND ADJUSTABLE POT RACK 1500MM

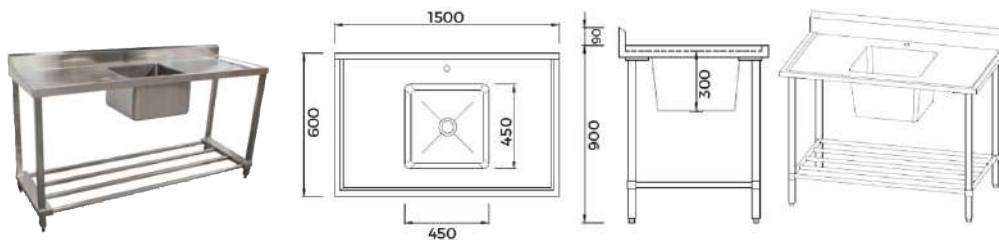

MODEL: 06-6-1500L

DIMENSIONS: 1500Wx600Dx900H

WEIGHT: 35 kg

- 38mm square tubes - adjustable feet - simple assembly - heavy duty construction - Sink size 450W x 450D x 300H - 32mm tap hole - 90mm waste hole



SINGLE SINK WITH SPLASHBACK AND ADJUSTABLE POT RACK 1800MM

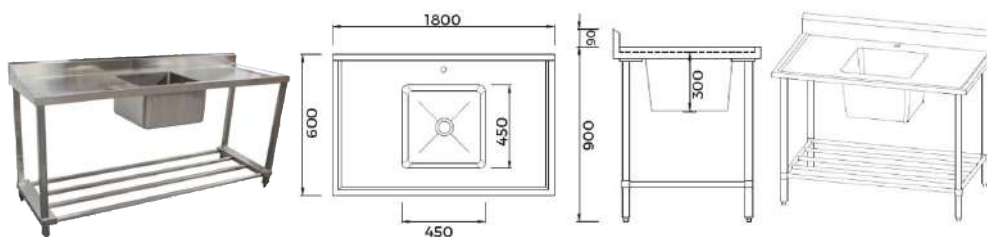

MODEL: 06-6-1800L

DIMENSIONS: 1800Wx600Dx900H

WEIGHT: 45 kg

- 38mm square tubes - adjustable feet - simple assembly - heavy duty construction - Sink size 450W x 450D x 300H - 32mm tap hole - 90mm waste hole



DOUBLE SINK WITH SPLASHBACK AND ADJUSTABLE POT RACK 1200MM

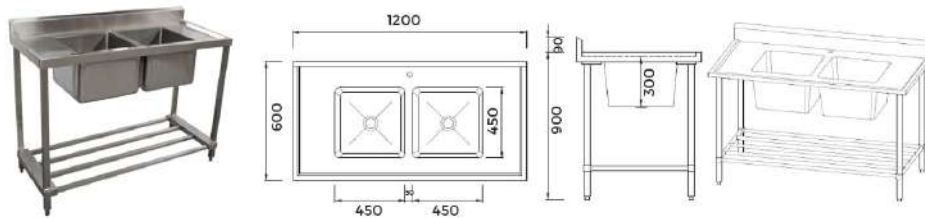

MODEL: 07-6-1200L

DIMENSIONS: 1200Wx600Dx900H

WEIGHT: 31 kg

- 38mm square tubes, adjustable feet - simple assembly - heavy duty construction - Sink size 450W x 450D x 300H - 32mm tap hole - 90mm waste hole



DOUBLE SINK WITH SPLASHBACK AND ADJUSTABLE POT RACK 1500MM

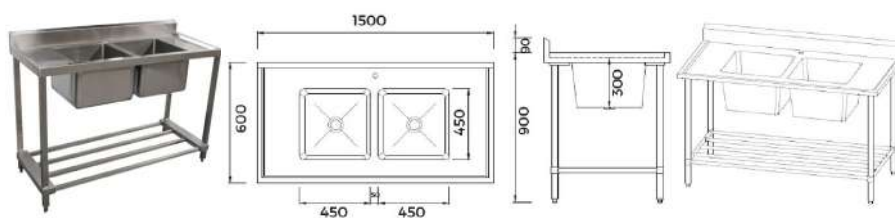

MODEL: 07-6-1500L

DIMENSIONS: 1500Wx600Dx900H

WEIGHT: 38 kg

- 38mm square tubes, adjustable feet - simple assembly - heavy duty construction - Sink size 450W x 450D x 300H - 32mm tap hole - 90mm waste hole



DOUBLE SINK WITH SPLASHBACK AND ADJUSTABLE POT RACK 1800MM

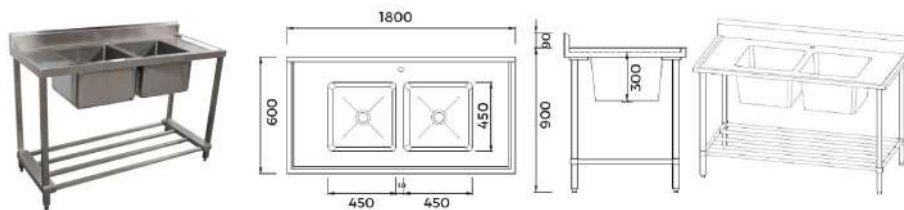

MODEL: 07-6-1800L

DIMENSIONS: 1800Wx600Dx900H

WEIGHT: 45 kg

- 38mm square tubes, adjustable feet - simple assembly - heavy duty construction - Sink size 450W x 450D x 300H - 32mm tap hole - 90mm waste hole



DOUBLE SINK WITH SPLASHBACK AND ADJUSTABLE POT RACK 2000MM

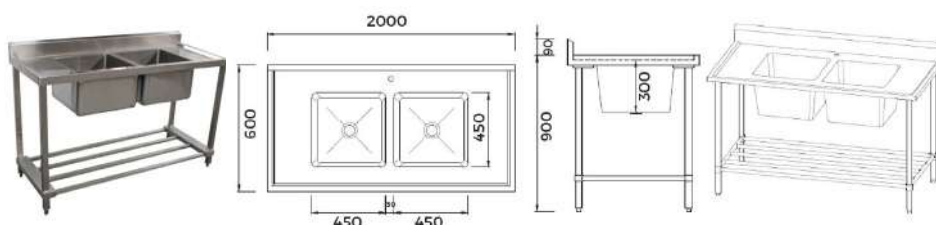

MODEL: 07-6-2000L

DIMENSIONS: 2000Wx600Dx900H

WEIGHT: 49 kg

- 38mm square tubes, adjustable feet - simple assembly - heavy duty construction - Sink size 450W x 450D x 300H - 32mm tap hole - 90mm waste hole



Please refer to the Spare Parts and Accessories booklet to see all the available optional extras. "Product" dimensions are given in mm and are approximate. Pictures are for illustrative purposes only. Given information may change without notice. For further information on any line drawings or missing product information, please call our head office on 03 9551 3034. All prices exclude GST. Freight charges apply.

DOUBLE SINK WITH SPLASHBACK AND ADJUSTABLE POT RACK 2400MM

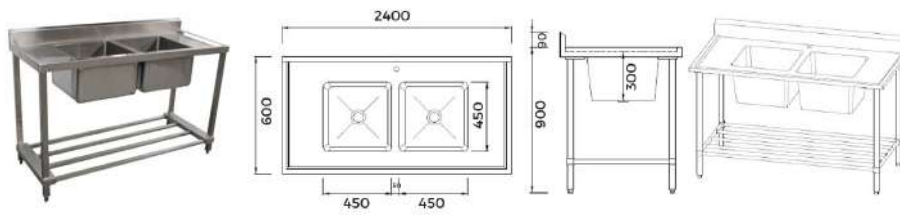
**MODEL:** 07-6-2400L**DIMENSIONS:** 2400Wx600Dx900H**WEIGHT:** 52 kg

- 38mm square tubes, adjustable feet - simple assembly - heavy duty construction - Sink size 450W x 450D x 300H - 32mm tap hole - 90mm waste hole

SOLID WALL SHELF WITH BRACKETS 900MM

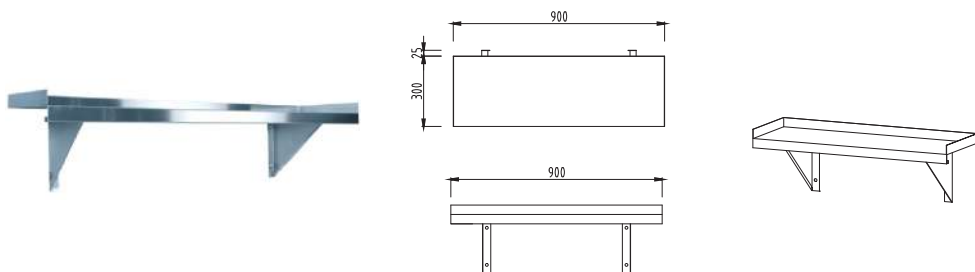

- 900mm wide - 1.2mm thick stainless steel brackets - 304 grade stainless steel - Easy to assemble
 - Screws for wall and shelf not included

MODEL: 08-900L

DIMENSIONS: 900Wx325Dx290H

WEIGHT: 5 kg



SOLID WALL SHELF WITH BRACKETS 1200MM

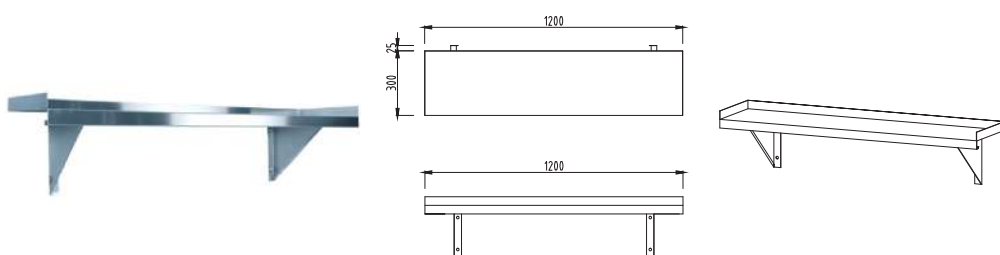

- 1200mm wide - 1.2mm thick stainless steel brackets - 304 grade stainless steel - Easy to assemble
 - Screws for wall and shelf not included

MODEL: 08-1200L

DIMENSIONS: 1200Wx325Dx290H

WEIGHT: 6 kg



SOLID WALL SHELF WITH BRACKETS 1500MM

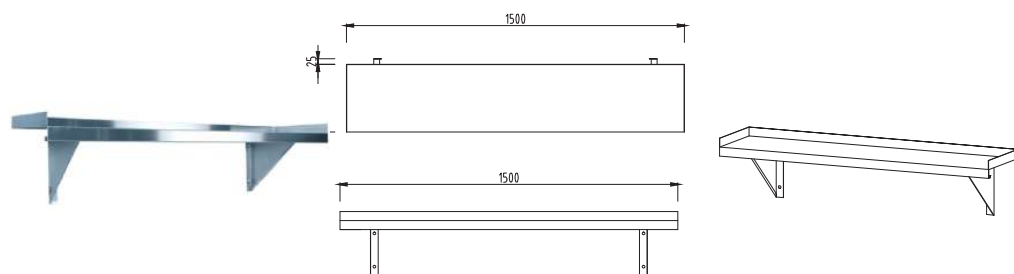

- 1500mm wide - 1.2mm thick stainless steel brackets - 304 grade stainless steel - Easy to assemble
 - Screws for wall and shelf not included

MODEL: 08-1500L

DIMENSIONS: 1500Wx325Dx290H

WEIGHT: 7 kg



SOLID WALL SHELF WITH BRACKETS 1800MM

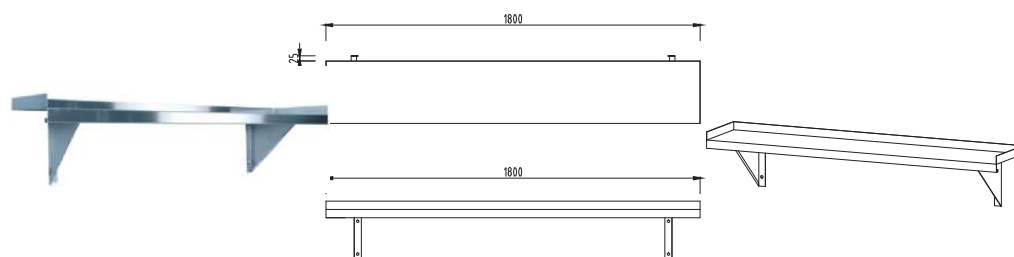

- 1800mm wide - 1.2mm thick stainless steel brackets - 304 grade stainless steel - Easy to assemble
 - Screws for wall and shelf not included

MODEL: 08-1800L

DIMENSIONS: 1800Wx325Dx290H

WEIGHT: 8 kg



SOLID WALL SHELF WITH BRACKETS 2400MM

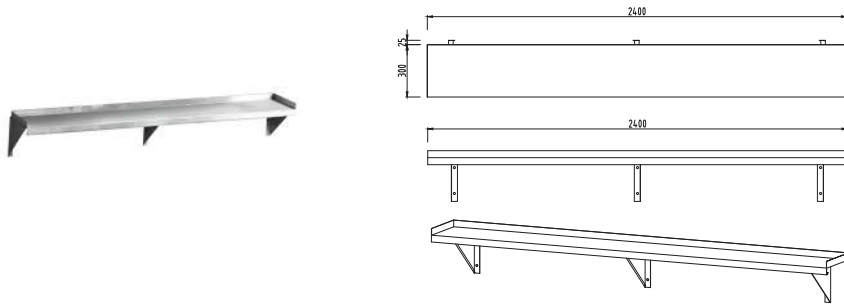

- 2400mm wide - 1.2mm thick stainless steel brackets - 304 grade stainless steel - Easy to assemble - Screws for wall and shelf not included

MODEL: 08-2400L

DIMENSIONS: 2400Wx325Dx290H

WEIGHT: 9 kg



MICROWAVE BENCH

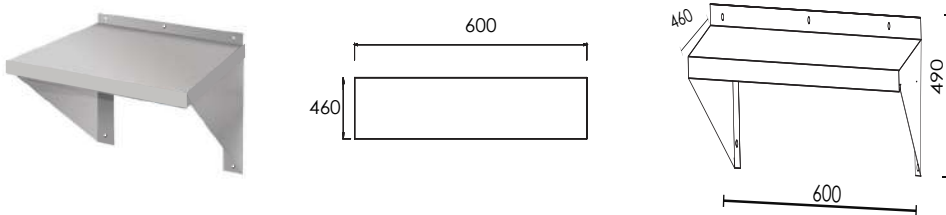

Stainless steel (430) Construction - Safe working load 35 Kg - Easy to clean and maintain - top notch finishing - Wall fixing additional Extra.

MODEL: 11-600L

DIMENSIONS: 600Wx460Dx490H

WEIGHT: 9 kg



PIPE WALL SHELF WITH BRACKETS 900MM

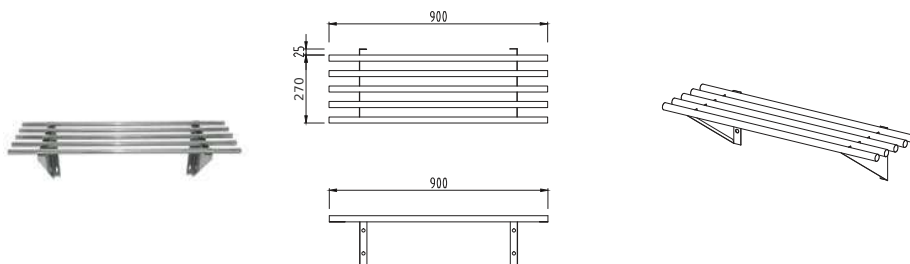

- 900mm wide - 1.2mm thick stainless steel brackets - Ø25mm stainless steel pipes with welded end caps - 304 grade stainless steel - Easy to assemble - Screws for wall and shelf not included

MODEL: 11-900L

DIMENSIONS: 900Wx295Dx210H

WEIGHT: 5 kg



PIPE WALL SHELF WITH BRACKETS 1200MM

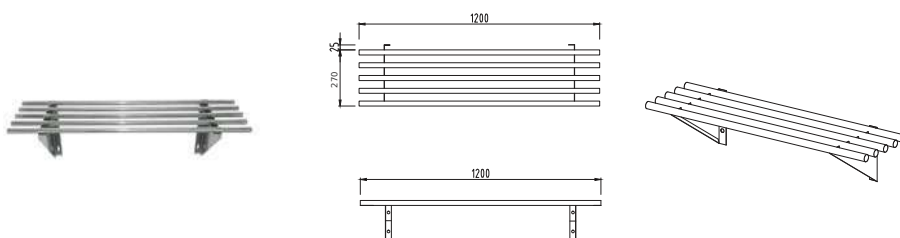

- 1200mm wide - 1.2mm thick stainless steel brackets - Ø25mm stainless steel pipes with welded end caps - 304 grade stainless steel - Easy to assemble - Screws for wall and shelf not included

MODEL: 11-1200L

DIMENSIONS: 1200Wx295Dx210H

WEIGHT: 5 kg



PIPE WALL SHELF WITH BRACKETS 1800MM

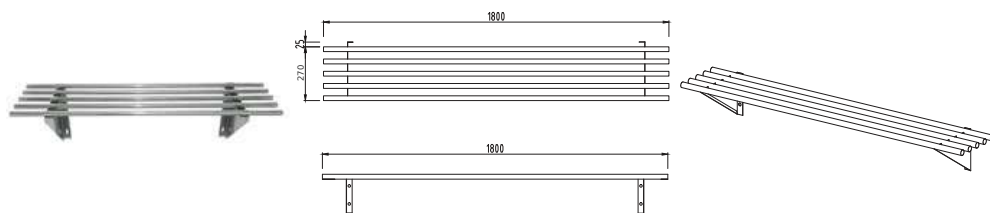

- 1800mm wide - 1.2mm thick stainless steel brackets - Ø25mm stainless steel pipes with welded end caps - 304 grade stainless steel - Easy to assemble - Screws for wall and shelf not included

MODEL: 11-1500L

DIMENSIONS: 1500Wx295Dx210H

WEIGHT: 6 kg



PIPE WALL SHELF WITH BRACKETS 1800MM

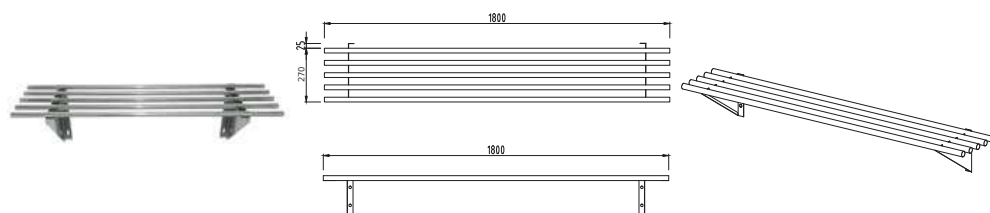

- 1800mm wide - 1.2mm thick stainless steel brackets - Ø25mm stainless steel pipes with welded end caps - 304 grade stainless steel - Easy to assemble - Screws for wall and shelf not included

MODEL: 11-1800L

DIMENSIONS: 1800Wx295Dx210H

WEIGHT: 7 kg



PIPE WALL SHELF WITH BRACKETS 2400MM

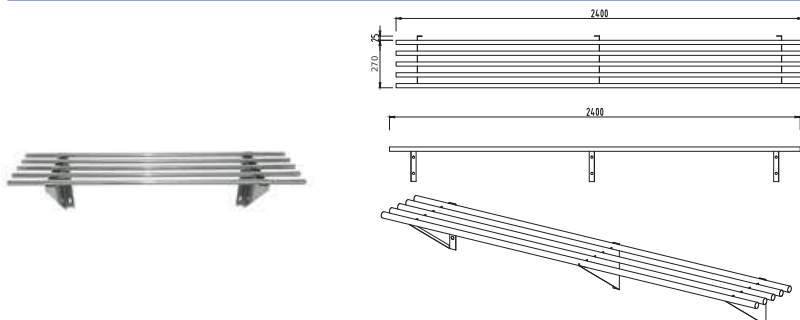

- 2400mm wide - 1.2mm thick stainless steel brackets - Ø25mm stainless steel pipes with welded end caps - 304 grade stainless steel - Easy to assemble - Screws for wall and shelf not included

MODEL: 11-2400L

DIMENSIONS: 2400Wx295Dx210H

WEIGHT: 7 kg



STAINLESS STEEL DRAWER WITH OUTSIDE FLANGE

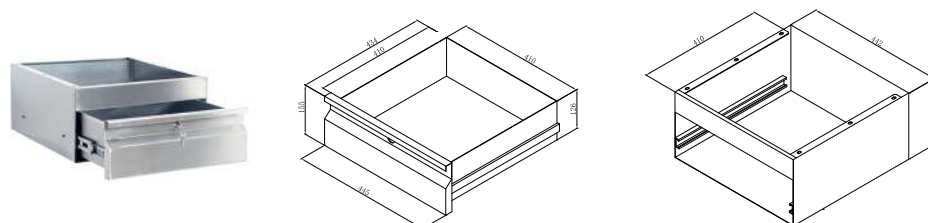

- Drawers to suit KSS Stainless Steel benches - Drawer with lock included - 304 grade stainless steel

MODEL: 10-S/S DRAW ONLY

DIMENSIONS: 450Wx450Dx210H

WEIGHT: 5 kg



2 TIER STAINLESS TROLLEY

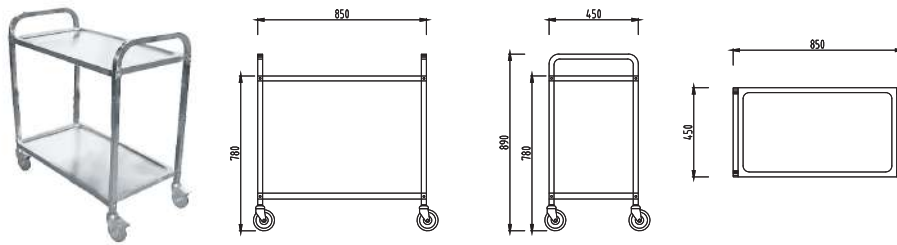

MODEL: 14-2T

DIMENSIONS: 850Wx450Dx890H

WEIGHT: 22 kg

- 100mm lockable castors - Pressed shelves for easy cleaning - Tray size: 450Wx800D - 304 grade stainless steel construction - Easy to assemble



3 TIER STAINLESS TROLLEY

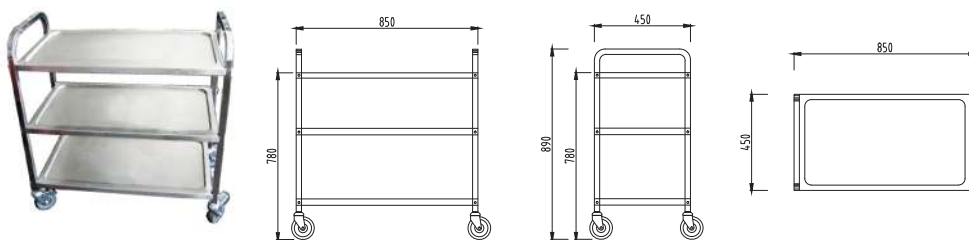

MODEL: 15-3T

DIMENSIONS: 850Wx450Dx890H

WEIGHT: 29 kg

- 100mm lockable castors - Pressed shelves for easy cleaning - Tray size: 450Wx800D - 304 grade stainless steel construction - Easy to assemble



MULTIPURPOSE UTILITY CART WITH BUCKETS SMALL

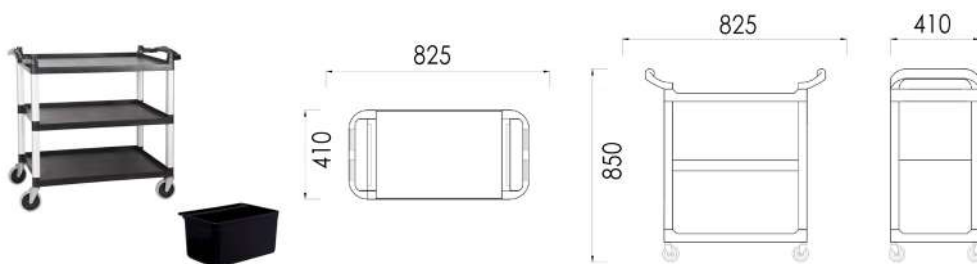

MODEL: PT-SMALL

DIMENSIONS: 825Wx410Dx850H

WEIGHT: 14 kg

- Three tier plastic trolley - Includes small removable holder (335Wx231Dx180H) - Easy to assemble



MULTIPURPOSE UTILITY CART WITH BUCKETS LARGE

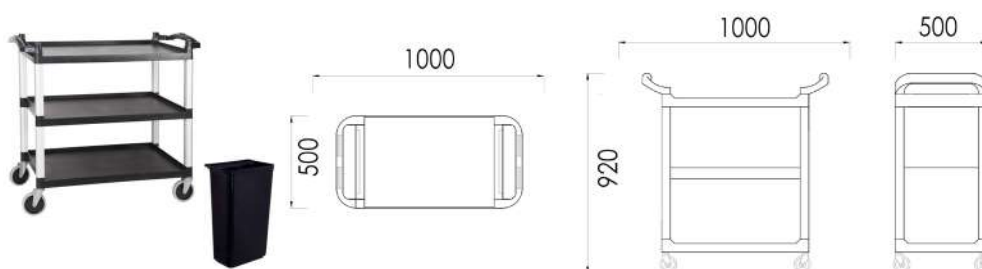

MODEL: PT-LARGE

DIMENSIONS: 1000Wx500Dx920H

WEIGHT: 19 kg

- Three tier plastic trolley - Includes large removable holder (335Wx231Dx445H) - Easy to assemble



MOBILE BAKERY RACK TROLLEY 10 TRAY (16"x29")

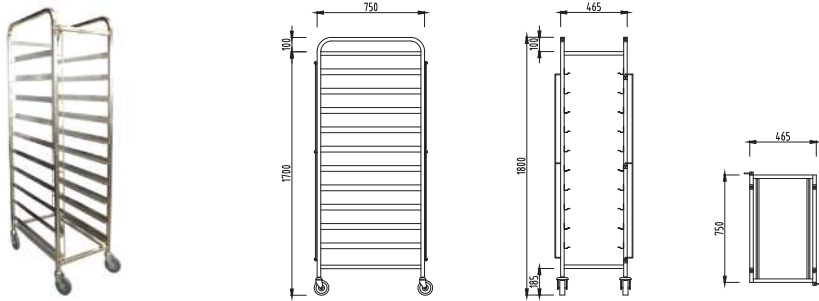

- 10 tray capacity: 16"x29" trays (457mmx737mm each) - 100mm high quality, non-marking, lockable castors - Tray lock on both sides for safe transport - Easy to assemble

MODEL: 1629-BAK-10

DIMENSIONS: 465Wx750Dx1800H

WEIGHT: 27 kg



MOBILE BAKERY RACK TROLLEY 15 TRAY (16"x29")

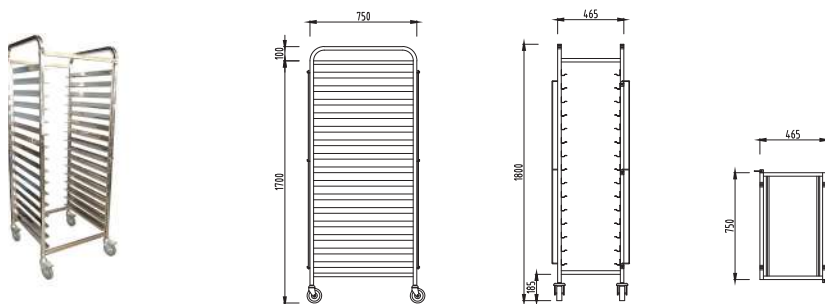

- 15 tray capacity: 16"x29" trays (457mmx737mm each) - 100mm high quality, non-marking, lockable castors - Tray lock on both sides for safe transport - Easy to assemble

MODEL: 1629-BAK-15

DIMENSIONS: 465Wx750Dx1800H

WEIGHT: 30 kg



MOBILE BAKERY RACK TROLLEY 10 TRAY (18"x29")

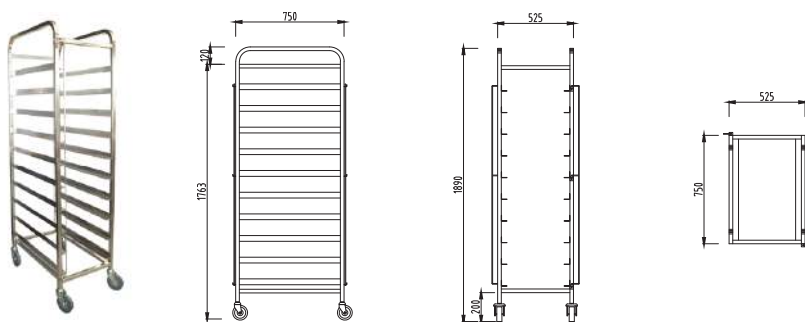

- 10 tray capacity: 18"x29" trays (457mmx737mm each) - 100mm high quality, non-marking, lockable castors - Tray lock on both sides for safe transport - Easy to assemble

MODEL: 1829-BAK-10

DIMENSIONS: 525Wx750Dx1890H

WEIGHT: 27 kg



MOBILE BAKERY RACK TROLLEY 15 TRAY (18"x29")

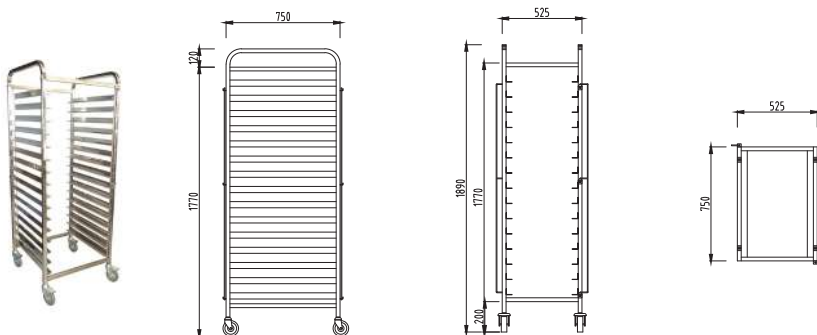

- 15 tray capacity: 18"x29" trays (457mmx737mm each) - 100mm high quality, non-marking, lockable castors - Tray lock on both sides for safe transport - Easy to assemble

MODEL: 1829-BAK-15

DIMENSIONS: 525Wx750Dx1860H

WEIGHT: 30 kg



MOBILE GASTRONORM TROLLEY 16 TRAY

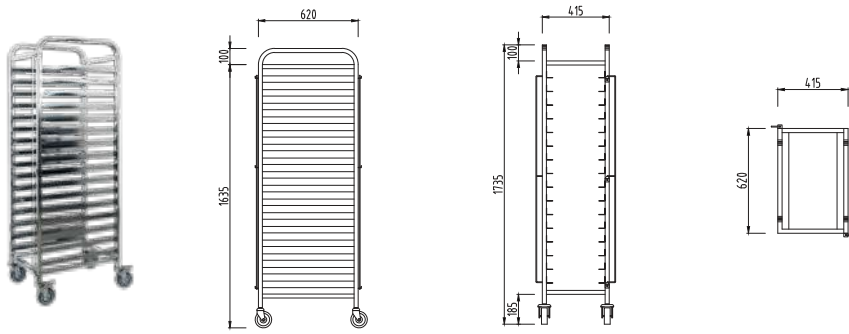

- Holds 16 x 1/1 GN trays - Lockable castors - Tray lock on both sides for safe transport - Easy to assemble

MODEL: GNM-16

DIMENSIONS: 415Wx620Dx1735H

WEIGHT: 30 kg



MOBILE GASTRONORM TROLLEY 32 TRAY

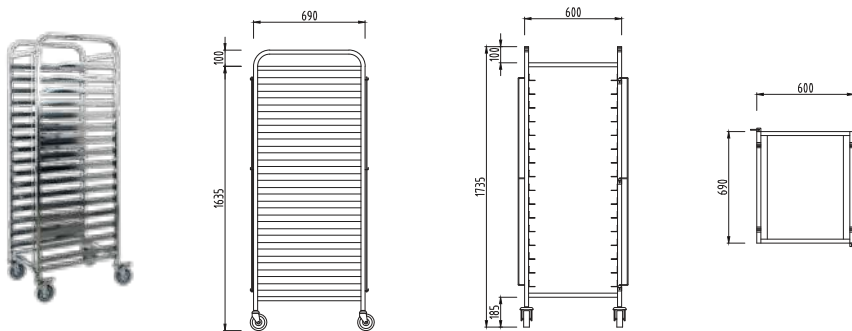

- Holds 32 x 1/1 or 16 x 2/1 GN trays - Lockable castors - Each shelf hold two 1/1 GN trays 65mm deep - Tray lock on both sides for safe transport - Easy to assemble

MODEL: GNM-32

DIMENSIONS: 600Wx690Dx1735H

WEIGHT: 33 kg



5 BASKET ANGLED TROLLEY

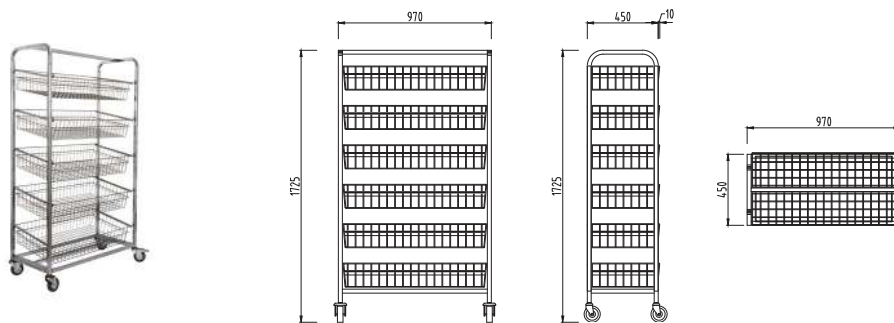

- Basket size: 912Wx460Dx153H - Chrome finish - Mild steel construction - On castors - Easy to assemble

MODEL: 5 BASKET ANGLED

DIMENSIONS: 970Wx460Dx1725H

WEIGHT: 40 kg



6 BASKET HORIZONTAL TROLLEY

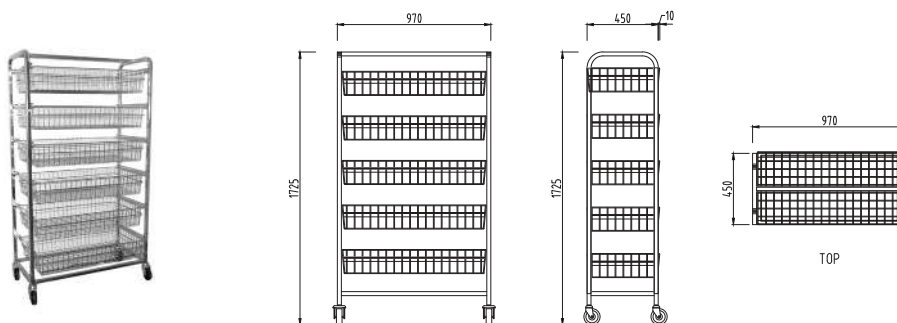

- Basket size: 912Wx460Dx153H - Chrome finish - Mild steel construction - On castors - Easy to assemble

MODEL: 5 BASKET HORIZ

DIMENSIONS: 970Wx500Dx1720H

WEIGHT: 58 kg



DISHWASHER RACK

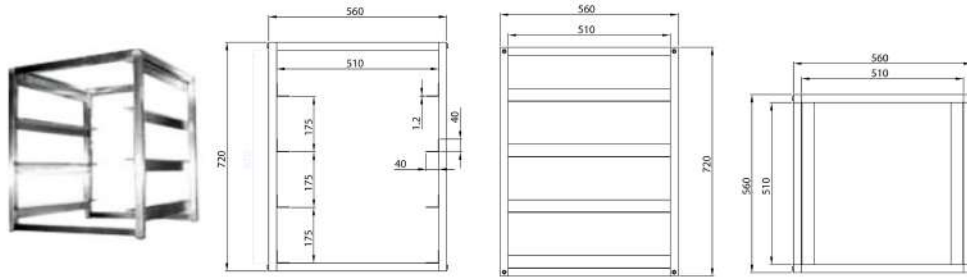

MODEL: 12-D/W BASK
DIMENSIONS: 560Wx560Dx620H
WEIGHT: 10 kg

- Adjustable feet - 304 grade stainless steel - Holds 3 dishwasher racks measuring 500Wx500Dx100H each - Suited to fit under KSS outlet bench - Easy to assemble



KNEE OPERATED/HANDS FREE SINK

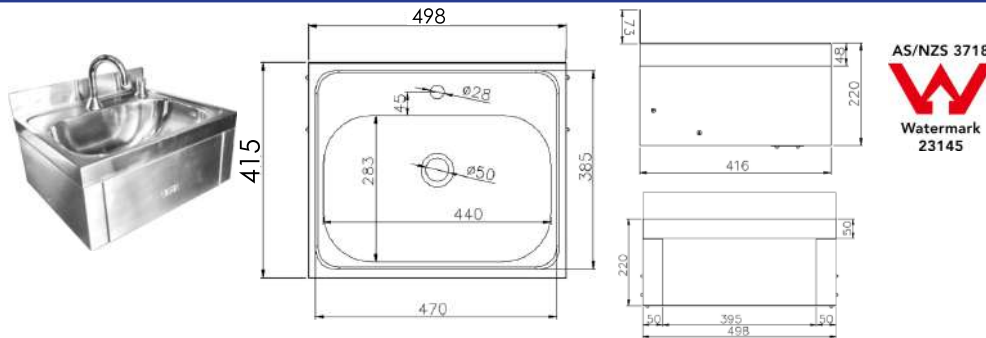

MODEL: MF-KNEE OPERATED SINK
DIMENSIONS: 498Wx415Dx293H
OUTPUT: N/A
WEIGHT: 13 kg

- High quality, full stainless steel construction - Includes soap pump and tap - Australian Watermark approved - No power connection required



MOP SINK WITH LEGS

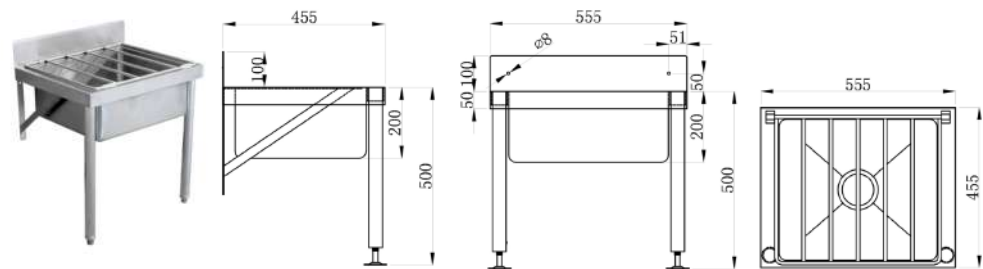

MODEL: MS-540
DIMENSIONS: 555Wx455Dx600H
OUTPUT: N/A
WEIGHT: 11 kg

- 90mm waste hole - High quality, full stainless steel construction - Complies with council regulations - **Tap is additional.**



ACCESSORIES



- Castors with brakes to suit 02- range of stainless steel benches - Heavy duty build - Non-marking

MODEL: BENCH CAS/BRAKE
DIMENSIONS: Ø100x27D

- Black Plastic Bush Insert Stopper to Suit Bench Leg

MODEL: BENCH BLACK INSERT
DIMENSIONS: 32Wx32Dx50H



- Stainless steel wire racks - Suits KSS Gastronorm trolleys - Ideal for use with steamers/combis

MODEL: WIRE RACKS GN 1/1
DIMENSIONS: 325Wx530Dx10D



Please refer to the Spare Parts and Accessories booklet to see all the available optional extras. "Product" dimensions are given in mm and are approximate. Pictures are for illustrative purposes only. Given information may change without notice. For further information on any line drawings or missing product information, please call our head office on 03 9551 3034. All prices exclude GST. Freight charges apply.

TITAN

MULTIPURPOSE SHELVING

Multipurpose Wire Shelving

Multipurpose Plastic Mat Shelving





5 YEAR WARRANTY

TITAN

- Multipurpose wire shelving systems and individual shelves - Suitable for cool rooms and freezer rooms - Galvanised and grey powder coated - Shelving systems include 4 shelves and shelf clips - Adjustable shelves - 250 kg/shelf load limit (without castors) - Flat packed for convenience - Easy to assemble - Available in various sizes and depths (355mm,455mm,610mm deep)

Shelving System

Model	Product Dimensions(mm)			Weight (kg)
	Width	Depth	Height	
CRSET 610x355	610	355	1825	12
CRSET 760x355	760	355	1825	13
CRSET 910x355	910	355	1825	14
CRSET 1060x355	1060	355	1825	15
CRSET 1220x355	1220	355	1825	17
CRSET 1370x355	1370	355	1825	22
CRSET 1525x355	1525	355	1825	24
CRSET 1825x355	1825	355	1825	29

Model	Product Dimensions(mm)			Weight (kg)
	Width	Depth	Height	
CRSET 610x455	610	455	1825	12
CRSET 760x455	760	455	1825	13
CRSET 910x455	910	455	1825	16
CRSET 1060x455	1060	455	1825	19
CRSET 1220x455	1220	455	1825	22
CRSET 1370x455	1370	455	1825	23
CRSET 1525x455	1525	455	1825	29
CRSET 1825x455	1825	455	1825	33

Model	Product Dimensions(mm)			Weight (kg)
	Width	Depth	Height	
CRSET 610x610	610	610	1825	14
CRSET 760x610	760	610	1825	16
CRSET 910x610	910	610	1825	21
CRSET 1060x610	1060	610	1825	25
CRSET 1220x610	1220	610	1825	29
CRSET 1370x610	1370	610	1825	33
CRSET 1525x610	1525	610	1825	36
CRSET 1825x610	1825	610	1825	44



5 YEAR WARRANTY

TITAN

- Multipurpose plastic mat shelving systems and individual shelves - Suitable for cool rooms and freezer rooms - Galvanised and grey powder coated - Shelving systems include 4 shelves and shelf clips - Adjustable shelves - Dishwasher safe mats - Fungi proofed - Easy to wash - Can withstand temperatures: -50°C to 200°C - Flat packed for convenience - Easy to assemble - Available in various sizes and depths (355mm,455mm,610mm deep)

Shelving System

Model	Product Dimensions(mm)			Weight (kg)
	Width	Depth	Height	
PMSET 610x355	610	355	1800	12
PMSET 910x355	910	355	1800	13
PMSET 1220x355	1220	355	1800	16
PMSET 1525x355	1525	355	1800	21
Model	Product Dimensions(mm)			Weight (kg)
	Width	Depth	Height	
PMSET 610x455	610	455	1800	10
PMSET 910x455	910	455	1800	14
PMSET 1220x455	1220	455	1800	18
PMSET 1525x455	1525	455	1800	22
Model	Product Dimensions(mm)			Weight (kg)
	Width	Depth	Height	
PMSET 610x610	610	610	1800	12
PMSET 910x610	910	610	1800	16
PMSET 1220x610	1220	610	1800	20
PMSET 1525x610	1525	610	1800	25

ACCESSORIES



- Castors with brakes to suit Titan plastic mat and wire shelving units

MODEL: TITAN CASTORS

DIMENSIONS: 100Wx50Dx180H



- Hook suited for Titan shelves for corner postless assembly

MODEL: TITAN HOOK

DIMENSIONS: 15Wx25Dx25H



-Post with bolt floor: for standard installation

MODEL: TITAN POST

DIMENSIONS: 30Wx30Dx1825H



- Black shelf clips (pair) to suit Titan shelving units

MODEL: TITAN CLIPS

DIMENSIONS: 31 Wx31 Dx45H



AMALFI COMMERCIAL

Electric Deck Ovens

Artisan Bakery Ovens

Wood Fired Ovens

Italian Convection Ovens

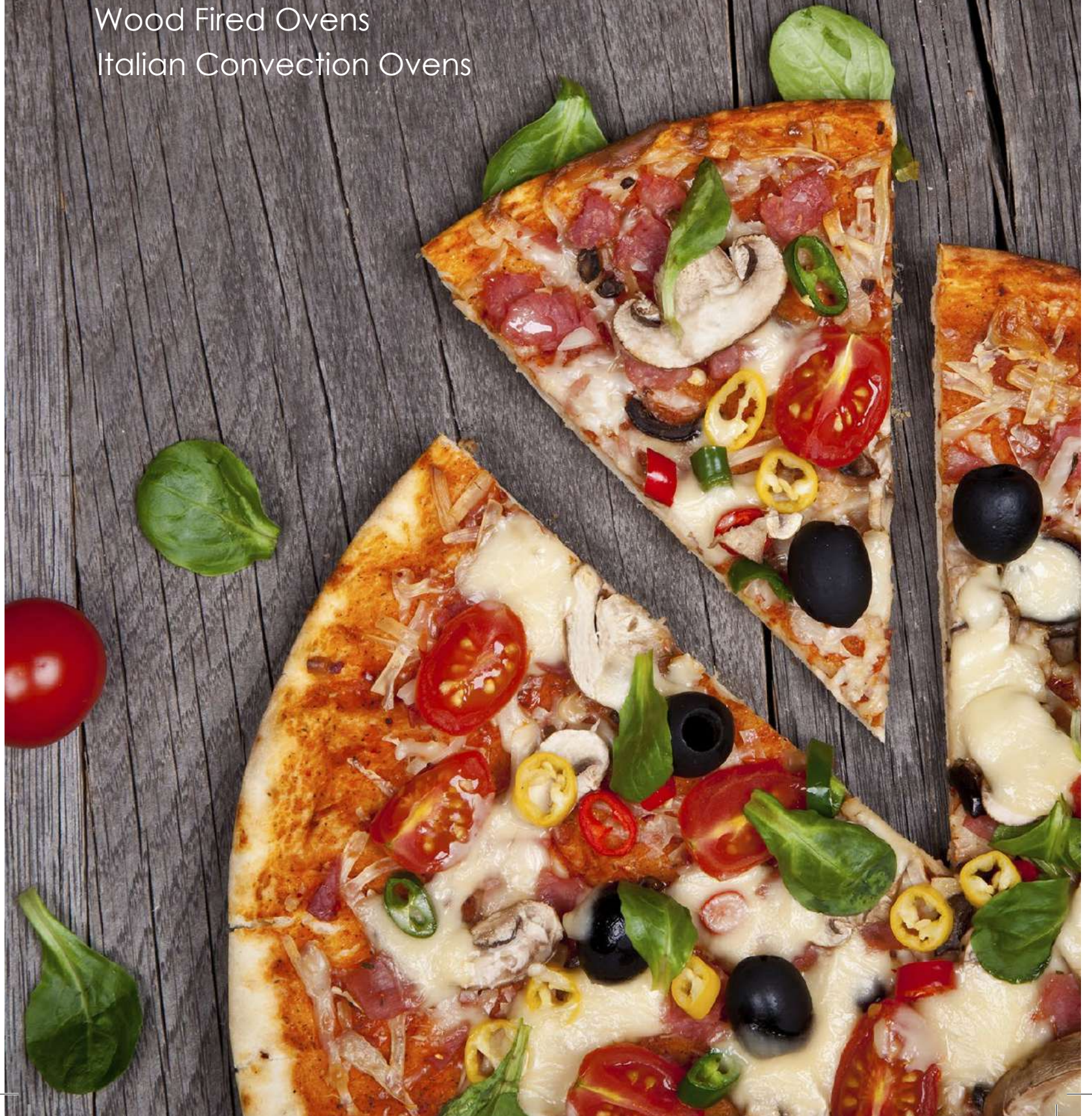

SINGLE LEVEL BENCHTOP ELECTRIC PIZZA OVEN

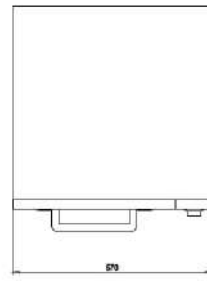
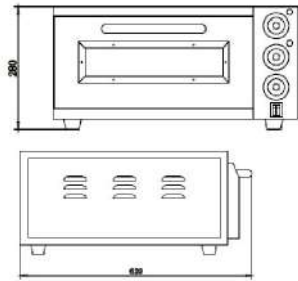

MODEL: PIZZA-1L

DIMENSIONS: 560Wx570Dx280H

OUTPUT: 1.6 kW

WEIGHT: 24 kg

- Chamber size: 400Wx400Dx115H - Pizza stone (395Wx395Dx13H) - One pizza stone included - Suitable for a single pizza up to 16" - Timer function - Temperature range: 50°C to 350°C - 240V 10A 50Hz



DOUBLE LEVEL BENCHTOP ELECTRIC PIZZA OVEN

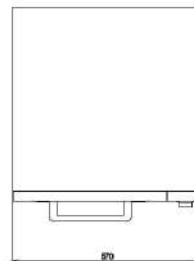
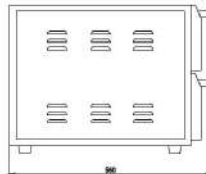
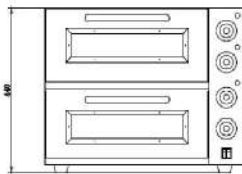

MODEL: PIZZA-2L

DIMENSIONS: 560Wx570Dx560H

OUTPUT: 2.4 kW

WEIGHT: 33 kg

- Chamber size: 400Wx400Dx115H - Pizza stone (395Wx395Dx13H) - Two pizza stones included - Suitable for two pizzas up to 16" - Timer function - Temperature range: 50°C to 350°C - 240V 15A 50Hz



10 AMP CONVECTION OVEN

Made in Italy

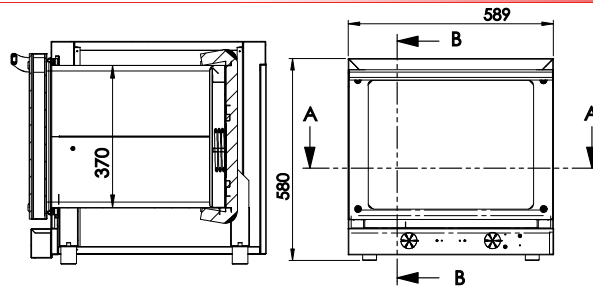

MODEL: A410A

DIMENSIONS: 589Wx660Dx580H

OUTPUT: 2.3 kw

WEIGHT: 33 kg

- Chamber size: 464Wx420Dx370H - Fits 1/1 GN Trays - Side opening door - Double glazed glass doors - Trays included - Temperature range: 50°C to 300°C - 240V 10A 50Hz



15 AMP CONVECTION OVEN

Made in Italy

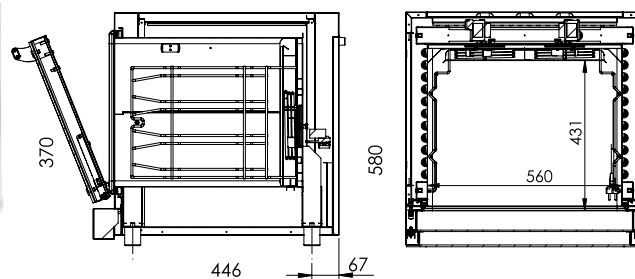

MODEL: A4GN15A

DIMENSIONS: 589Wx660Dx580H

OUTPUT: 3.2 kw

WEIGHT: 35 kg

- Chamber size: 650Hx460Dx350H - Fits 1/1 GN Trays - Side opening door - Double glazed glass doors - Trays included - Temperature range: 50°C to 300°C - 240V 15A 50Hz



ELECTRIC ONE DECK OVEN

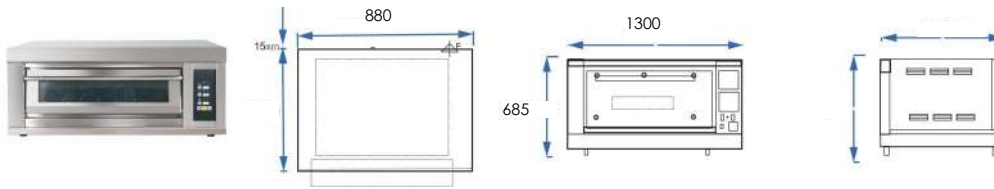

MODEL: 1D2T

DIMENSIONS: 1300Wx880Dx685H

OUTPUT: 6.6 kW

WEIGHT: 100 Kg

Outside material: 0.8 s/s 430, -Inside: 0.8 Alum coated steel, -Front: 0.8 s/s 430, -Front Door with Seal (with angle), -Wheel Front Brakes Back(black),- Door with Chain and Spring,- Power: 19.8 kw Digital display Control Panel, With Timer, Optional extra Stone base.



ELECTRIC TWO DECK OVEN

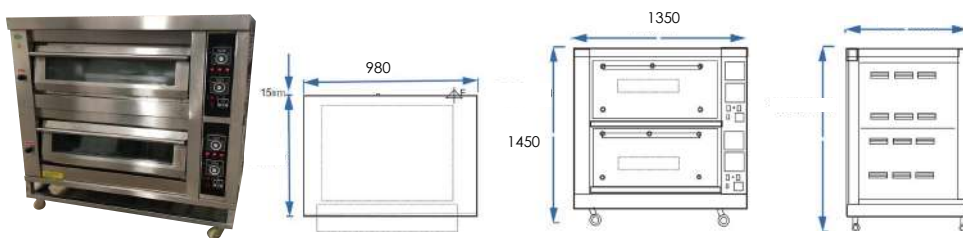

MODEL: 2D4T

DIMENSIONS: 1350Wx980Dx1450H

OUTPUT: 13.2 kW

WEIGHT: 170 kg

- Unit includes stand with castors - Each deck fits two Euronorm trays (600x400mm) - Four trays included - Chamber size: 830W x 625D x 190H- 415V 3Phase+Neutral+Earth 20A 50Hz Optional extra Stone base



ELECTRIC THREE DECK OVEN - 6 TRAY

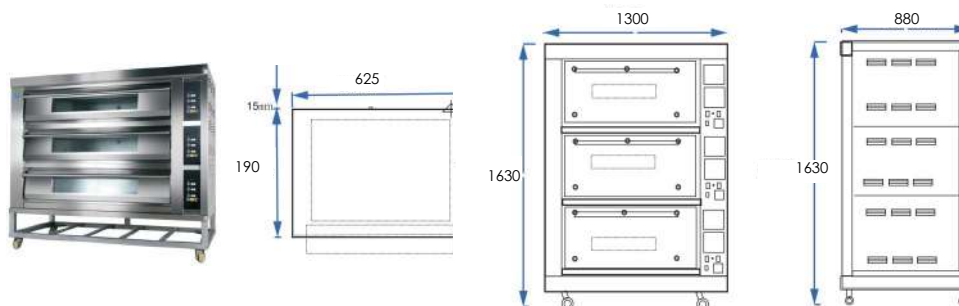

MODEL: 3D6T

DIMENSIONS: 1300Wx880Dx1630H

OUTPUT: 19.8 kW

WEIGHT: 255 kg

- Each deck fits two Euronorm trays (600x400mm) - Six trays included - Chamber size: 830W x 625D x 190H - On Castors - 415V 3Phase+Neutral+Earth 30A 50Hz,Optional extra Stone base



ELECTRIC THREE DECK OVEN - 9 TRAY

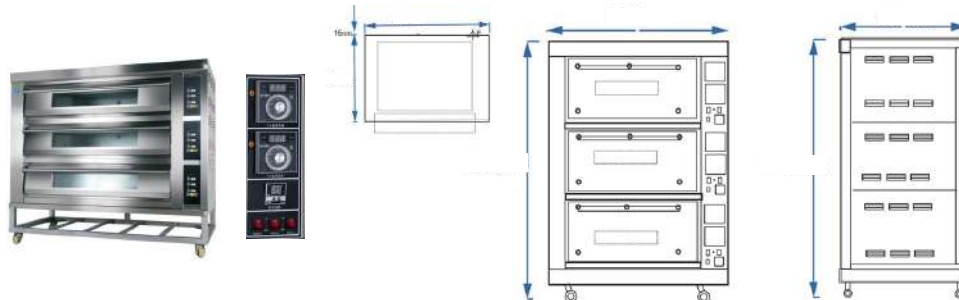

MODEL: 3D9T

DIMENSIONS: 1800Wx800Dx1630H

OUTPUT: 24 kW

WEIGHT: 320 kg

- Each deck fits three Euronorm trays (600x400mm) - Nine trays included - Chamber size: 1240W x 625D x 190H - On Castors - 415V 3Phase+Neutral+Earth 45A 50Hz,Optional extra Stone base



ELECTRIC ONE DECK BAKERY OVEN WITH STONE BASE

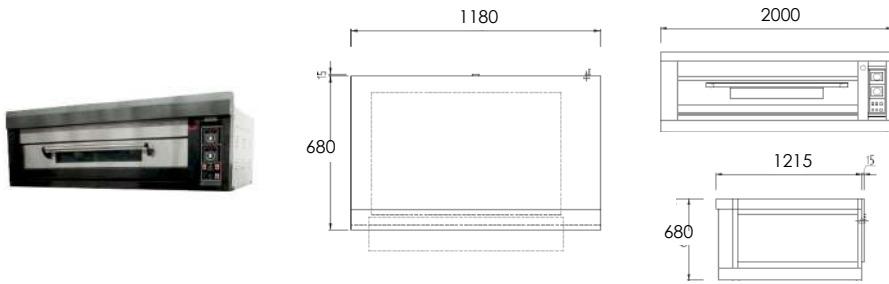

MODEL: 1DBAK
DIMENSIONS: 2000Wx1180Dx680H
OUTPUT: 19.2 kW
WEIGHT: 150 kg

- Steam Generator on deck- Stone base - Stand available as optional accessory: POA - Deck accommodates 3 trays + bread tins - Chamber size: 1500W x 1215D x 200H - 415V 3Phase+Neutral+Earth 15A 50Hz - **Stone base included.**



ELECTRIC TWO DECK BAKERY OVEN WITH STONE BASE

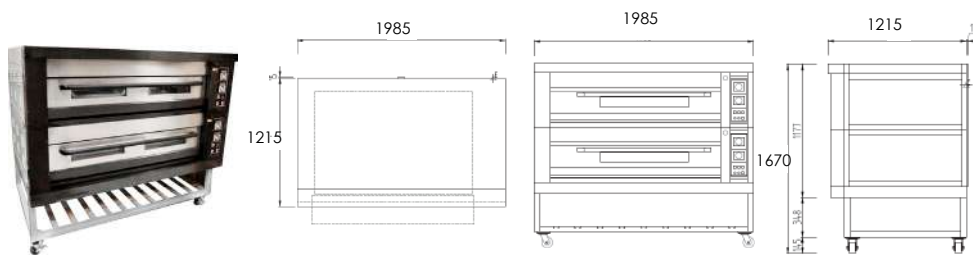

MODEL: 2DBAK
DIMENSIONS: 1985Wx1215Dx1670H
OUTPUT: 38.4 kW
WEIGHT: 300 kg

- Steam Generator on deck - Stand available as optional accessory: POA - Each deck accommodates 3 trays + bread tins - Chamber size: 1500W x 1215D x 200H - 415V 3Phase+Neutral+Earth 25A 50Hz



ELECTRIC THREE DECK BAKERY OVEN WITH

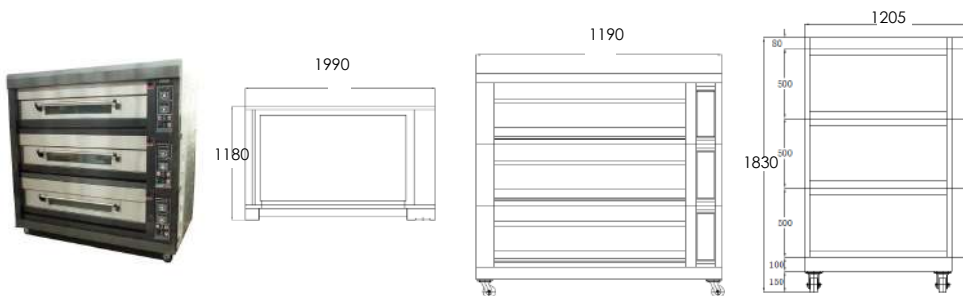

MODEL: 3DBAK
DIMENSIONS: 1995Wx1215Dx1830H
OUTPUT: 57.5 kW
WEIGHT: 425 kg

- Steam Generator on deck - Castors included - Each deck accommodates 3 trays + bread tins - Chamber size: 1500W x 1215D x 200H - 415V 3Phase+Neutral+Earth 45A 50Hz - **Stone base included.**



WOODFIRED OVEN - SMALL

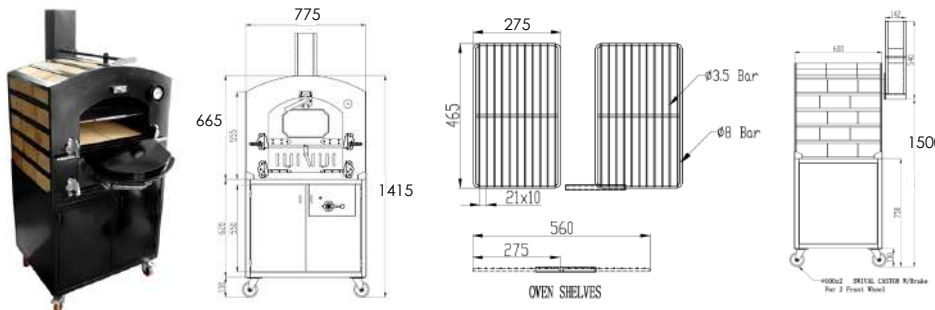

MODEL: Woodfired Oven - Small
DIMENSIONS: 755Wx740Dx1500H
OUTPUT: N/A
WEIGHT: 320 kg

- Brick floor size: 500Wx470D - Suitable for producing four 9" pizzas at once - Efficient heat retention - Removable bricks and grates for easy cleaning - On castors for increased mobility.



WOODFIRED OVEN - LARGE

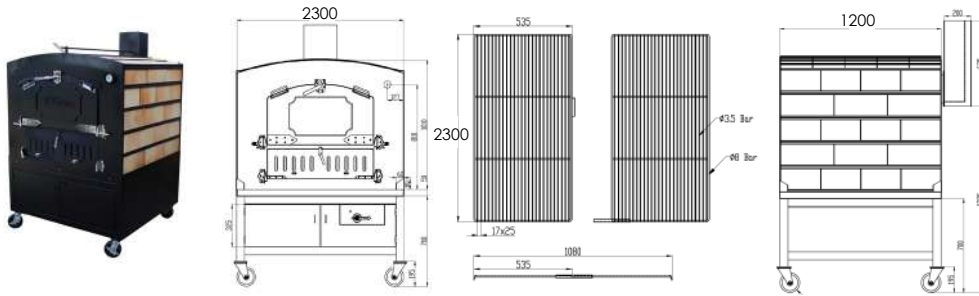

MODEL: Woodfired Oven - Large

DIMENSIONS: 1300Wx1400Dx1760H

OUTPUT: 100Mj/hr(NG)/90Mj/hr(LPG)

WEIGHT: 1120 kg

- Brick floor size: 1080Wx1050D - Suitable for producing eight 10" pizzas at once - Efficient heat retention - Separated fire box for clean cooking - Removable bricks and grates for easy cleaning - On castors for increased mobility



PORTABLE PIZZA OVEN

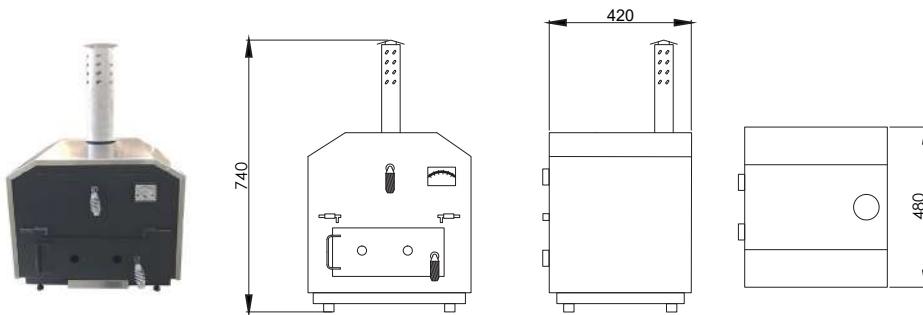

MODEL: PPO-420

DIMENSIONS: 480Wx420Dx740H

OUTPUT: N/A

WEIGHT: 37 kg

- Food cooking chamber size: 380Wx370Dx180H - External thermometer, Charcoal/Wood burning chamber (380Wx370Dx130H) - Steel construction with heat resistant paint, stainless steel cover





tandoor

TANDOORI OVENS
Tandoor Clay Ovens

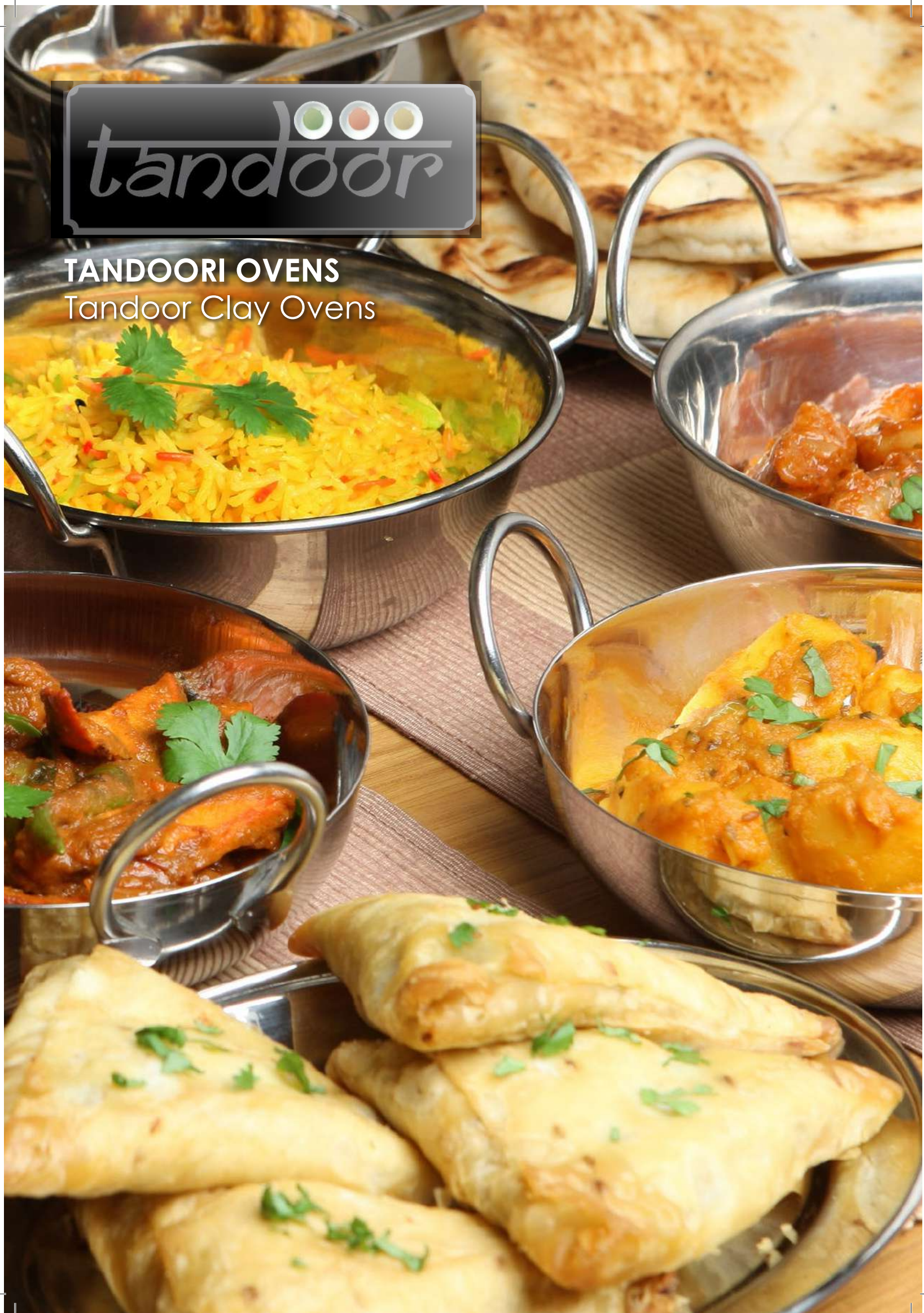

SQUARE TANDOOR OVEN - SMALL

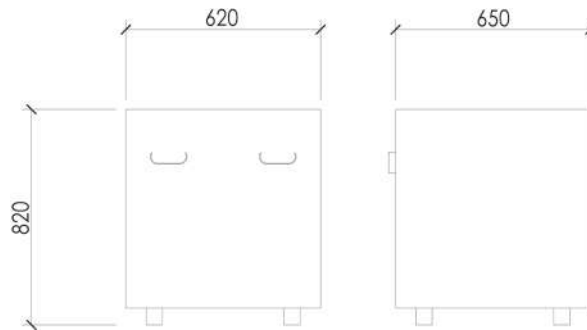

MODEL: TAN600

DIMENSIONS: 650Wx620Dx820H

OUTPUT: 82 Mj/hr (NG)/60 Mj/hr (LPG)

WEIGHT: 200 kg

-Stainless steel construction - Fired clay (to 1300°C) interior surface improves heat retention and distribution - Six skewers included - On castors - Available in Natural Gas or LPG Gas parts made in Australia.

SQUARE TANDOOR OVEN - SMALL

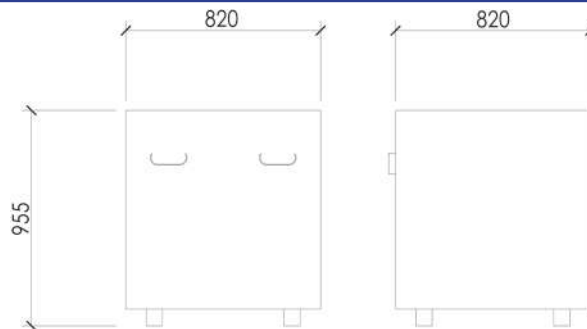

MODEL: TAN820IND

DIMENSIONS: 820Wx820Dx955H

OUTPUT: 85Mj/hr(NG)/80Mj/hr(LPG)

WEIGHT: 225 kg

-Stainless steel construction - Fired clay interior surface in forces heat retention -Comes on castors - Made in India - Available in Natural Gas or LPG or charcoal - Gas parts made in Australia.

SQUARE TANDOOR OVEN - LARGE

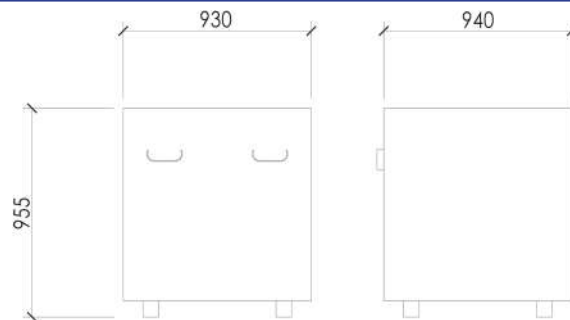

MODEL: TAN920IND

DIMENSIONS: 940Wx930Dx955H

OUTPUT: 85Mj/hr(NG)/80Mj/hr(LPG)

WEIGHT: 380 kg

-Stainless steel construction - Fired clay interior surface in forces heat retention -Comes on castors - Made in India - Available in Natural Gas, LPG or charcoal - Gas parts made in Australia.



INSTALLATION KIT

Kit Includes: Restraining cable, flexible hose & gas ball valve.



MAESTRO MIX

MIXERS, PIZZA & BAKERY EQUIPMENT

Planetary Mixers

Spiral Mixers

Pastry & Dough Sheeters

Bun Dividers & Roll Moulders

Fermenting Provers

Bread Slicers

HEAVY DUTY 10 LITRE PLANETARY MIXER

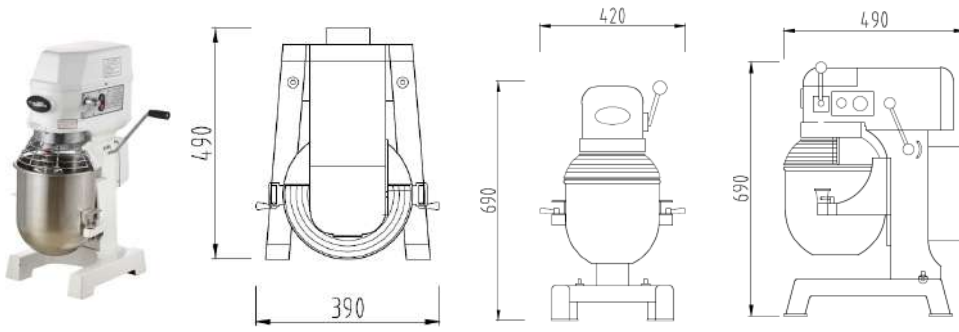

MODEL: P10MAE
DIMENSIONS: 420Wx490Dx690H
OUTPUT: 0.37 Kw
WEIGHT: 65 kg

- Capacity: 10 litres - Includes 3 attachments: hook, beater & whisk - 3 speed gearbox - Safety guard with lowering arm - "Missing bowl" safety switch - CE approved - 240V 10A 50Hz

MAESTRO MIX

HEAVY DUTY 20 LITRE PLANETARY MIXER

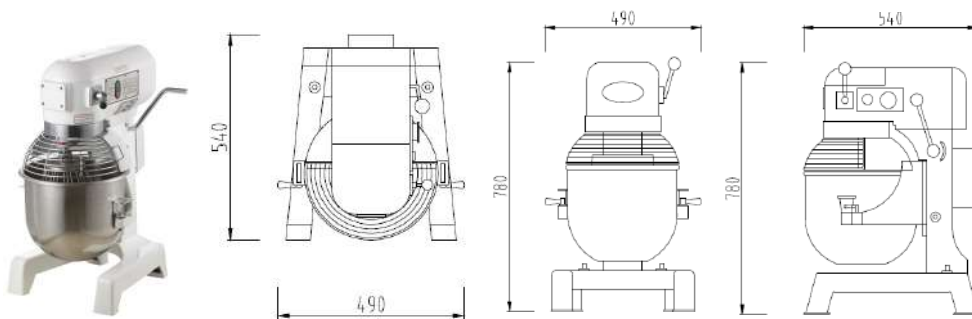

MODEL: P20MAE
DIMENSIONS: 490Wx540Dx780H
OUTPUT: 1.1Kw
WEIGHT: 86 kg

- Capacity: 20 litres - Includes 3 attachments: hook, beater & whisk - 3 speed gearbox - Safety guard with lowering arm - "Missing bowl" safety switch - CE approved - 240V 10A 50Hz

MAESTRO MIX

HEAVY DUTY 40 LITRE PLANETARY MIXER

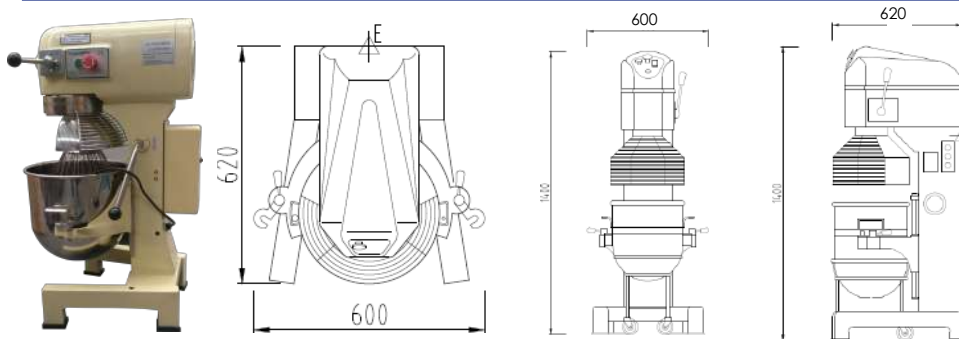

MODEL: P40MAE
DIMENSIONS: 620Wx600Dx1400H
OUTPUT: 2 Kw
WEIGHT: 248 kg

- Capacity: 40 litres - Includes 3 attachments: hook, beater & whisk - 3 speed gearbox - Safety guard with lowering arm - "Missing bowl" safety switch - CE approved - 240V 15A 50Hz

MAESTRO MIX

HEAVY DUTY 60 LITRE PLANETARY MIXER

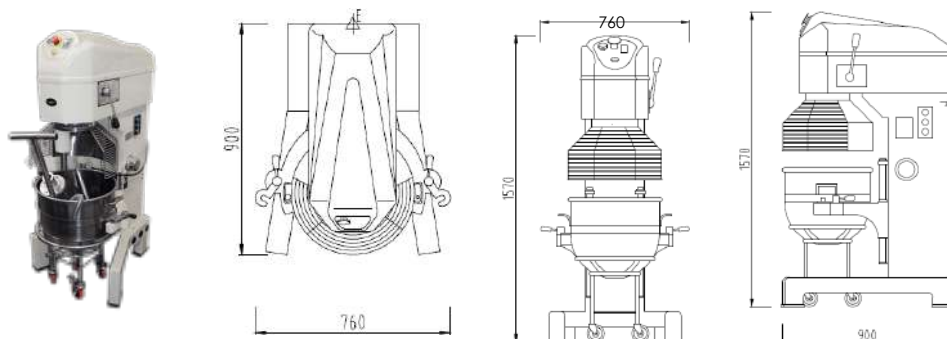

MODEL: P60MAE
DIMENSIONS: 760Wx900Dx1570H
OUTPUT: 6 Kw
WEIGHT: 460 kg

- Capacity: 60 litres - Includes 4 attachments: hook, beater, whisk & bowl trolley - 3 speed gearbox - Safety guard with lowering arm - "Missing bowl" safety switch - CE approved - 415V 15A 50Hz 3 Phase

MAESTRO MIX

HEAVY DUTY 80 LITRE PLANETARY MIXER

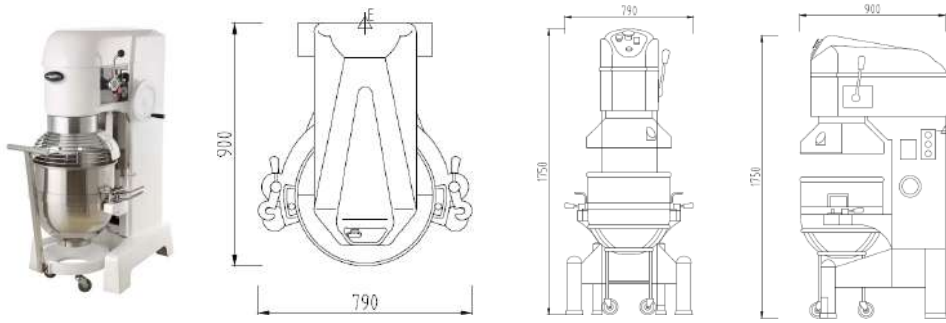

MODEL: P80MAE
DIMENSIONS: 790Wx900Dx1750H
OUTPUT: 10.4 Kw
WEIGHT: 720 kg

- Capacity: 80 litres - Includes 4 attachments: hook, beater, whisk & bowl trolley - Integrated electric bowl lifting mechanism - 3 speed gearbox - Safety guard with lowering arm - "Missing bowl" safety switch - Includes bowl trolley - CE approved - 415V 15A 50Hz 3 Phase



HEAVY DUTY 5 KG SPIRAL MIXER - SINGLE SPEED

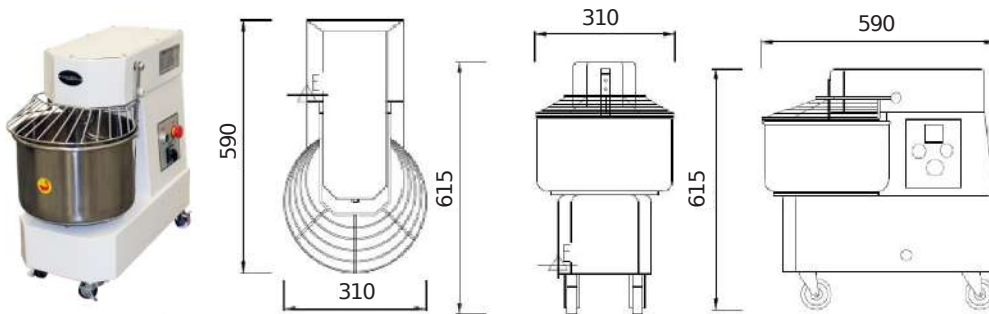

MODEL: S10MAE1S
DIMENSIONS: 310Wx590Dx615H
OUTPUT: 0.55 Kw
WEIGHT: 42 kg

- Capacity: maximum 5 kg dry bread flour with 55% water - Gear chain driven, single speed motor - Safety guard - 240V 10A 50Hz



HEAVY DUTY 8 KG SPIRAL MIXER - SINGLE SPEED

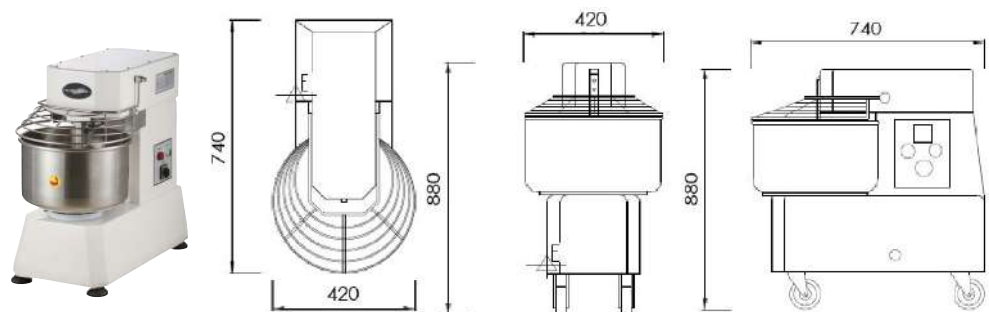

MODEL: S20MAE1S
DIMENSIONS: 420Wx740Dx880H
OUTPUT: 0.75 Kw
WEIGHT: 88 kg

- Capacity: maximum 8 kg dry bread flour with 55% water - Gear chain driven, single speed motor - Safety guard - 240V 10A 50Hz



HEAVY DUTY 12.5 KG SPIRAL MIXER - SINGLE SPEED

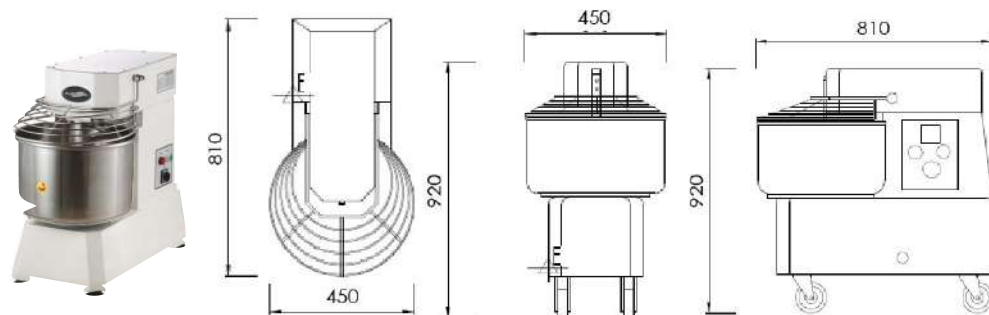

MODEL: S30MAE1S
DIMENSIONS: 450Wx810Dx920H
OUTPUT: 1.1 Kw
WEIGHT: 100 kg

Capacity: maximum 12.5 kg dry bread flour with 55% water - Chain driven, single speed motor - Safety guard - 240V 10A 50Hz



HEAVY DUTY 18 KG SPIRAL MIXER - SINGLE SPEED

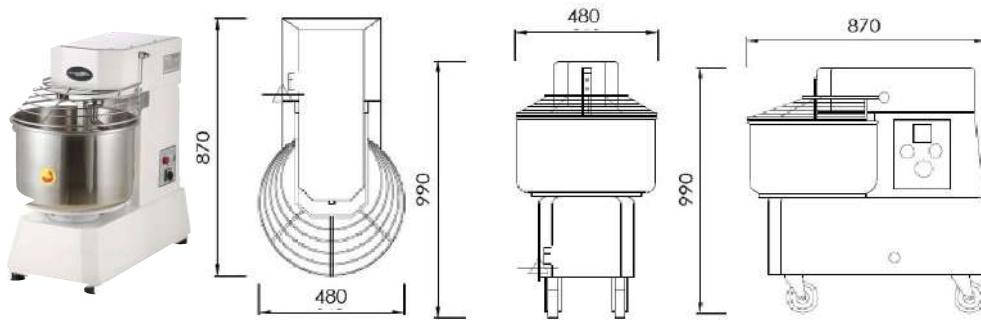

MODEL: S40MAE1S
DIMENSIONS: 480Wx870Dx990H
OUTPUT: 2.2 Kw
WEIGHT: 136 kg

Capacity: maximum 18 kg dry bread flour with 55% water - Chain driven, single speed motor - 240V 15A 50Hz

MAESTRO MIX

HEAVY DUTY 25 KG SPIRAL MIXER - SINGLE SPEED

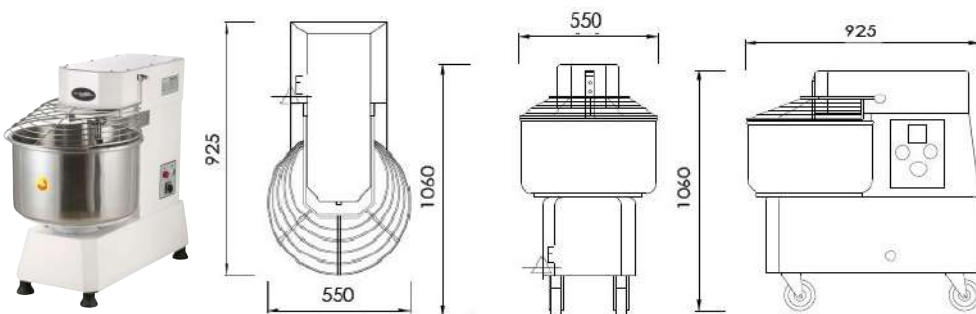

MODEL: S50MAE1S
DIMENSIONS: 550Wx925Dx1060H
OUTPUT: 2.2Kw
WEIGHT: 125 kg

- Capacity: maximum 25 kg dry bread flour with 55% water - Chain driven, single speed motor - 240V 15A 50Hz

MAESTRO MIX

HEAVY DUTY 25 KG SPIRAL MIXER - TWO SPEED

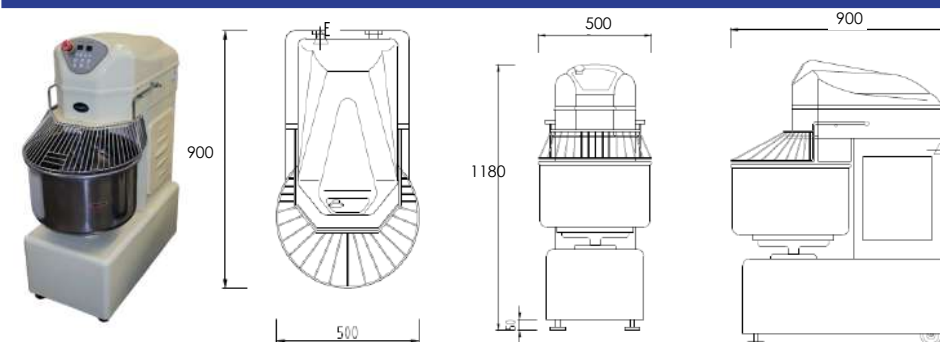

MODEL: S40MAE2S
DIMENSIONS: 500Wx900Dx1180H
OUTPUT: 1.8 Kw
WEIGHT: 256 kg

- Capacity: maximum 20 kg dry bread flour with 55% water - Computerised touchpad - 2 speed with timer - Safety guard and safety switches - 415V 10A - 3 phase

MAESTRO MIX

HEAVY DUTY 25 KG SPIRAL MIXER - TWO SPEED - REVERSE

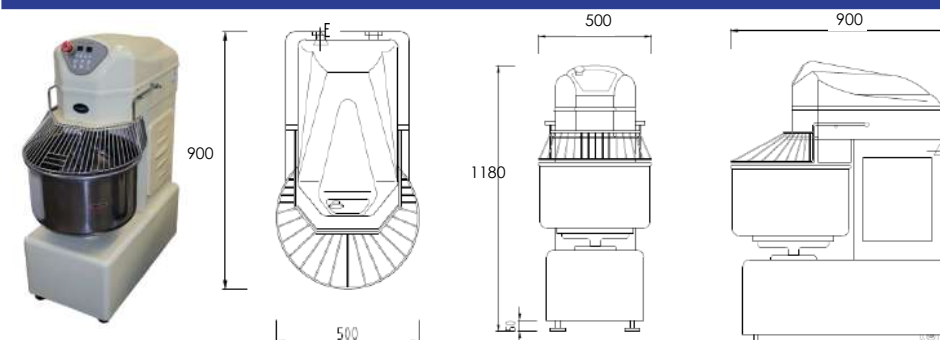

MODEL: S40MAE2S - R
DIMENSIONS: 500Wx900Dx1180H
OUTPUT: 1.8 Kw
WEIGHT: 256 kg

- Capacity: maximum 20 kg dry bread flour with 55% water - Computerised touchpad - Reverse Function - 2 speed with timer - Safety guard and safety switches - 415V 10A - 3 phase

MAESTRO MIX

HEAVY DUTY 50 KG SPIRAL MIXER - TWO SPEED

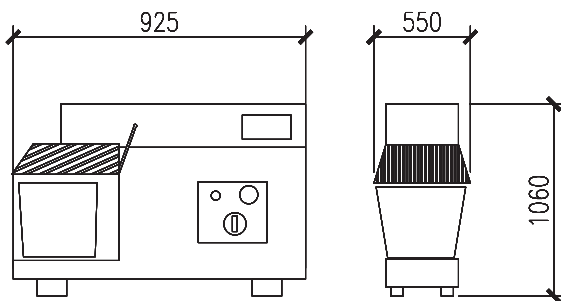

MODEL: S50MAE2S
DIMENSIONS: 550Wx925Dx1060H
OUTPUT: 2.9 Kw
WEIGHT: 150 kg

- Heavy duty spiral mixer - 2 speeds - 17 Amps, 415 v - 50 kg dry bread flour with 55% water
- Safety guard and safety switch - Reverse bowl operation - Suitable for bread



HEAVY DUTY 50 kg SPIRAL MIXER - TWO SPEED

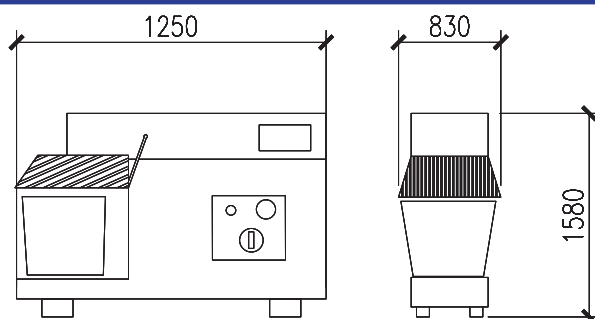

MODEL: S130MAE2S
DIMENSIONS: 830Wx1250Dx1580H
OUTPUT: 5.6 Kw
WEIGHT: 567 kg

- Heavy duty spiral mixer - 2 speeds - 17 Amps, 415 v - 50 kg dry bread flour with 55% water
- Safety guard and safety switch - Reverse bowl operation



HEAVY DUTY 75 kg SPIRAL MIXER - TWO SPEED

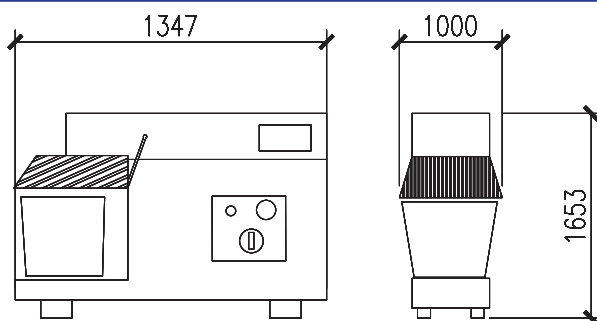

MODEL: S200MAE2S
DIMENSIONS: 1000Wx1347Dx1653H
OUTPUT: 7.5 Kw
WEIGHT: 735 kg

- Heavy duty spiral mixer - 2 speeds - 21 Amps, 415 v - 75 kg dry bread flour with 55% water
- Safety guard and safety switch - Reverse bowl operation



HEAVY DUTY 3 PHASE SPIRAL MIXER - 50kg

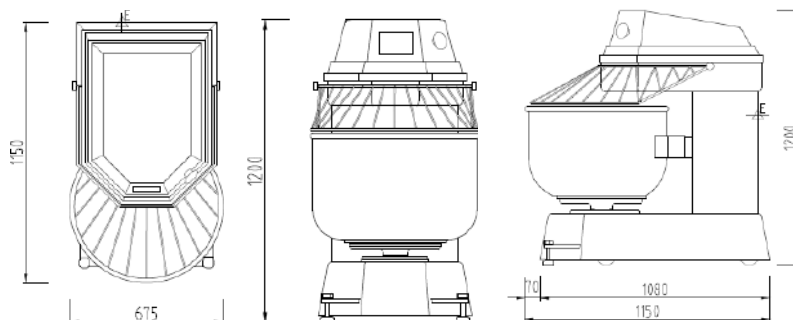

MODEL: 2BAGS50MAE
DIMENSIONS: 675Wx1150Dx1200H
OUTPUT: 5.4 Kw
WEIGHT: 400 kg

- Capacity: maximum 50 kg dry bread flour with 55% water - Computerised touchpad - Variable speed with timer - Safety guard and safety switches - 415V 15A 50Hz 3 Phase



Please refer to the Spare Parts and Accessories booklet to see all the available optional extras. "Product" dimensions are given in mm and are approximate. Pictures are for illustrative purposes only. Given information may change without notice. For further information on any line drawings or missing product information, please call our head office on 03 9551 3034. All prices exclude GST. Freight charges apply.

HEAVY DUTY 75 KG SPIRAL MIXER

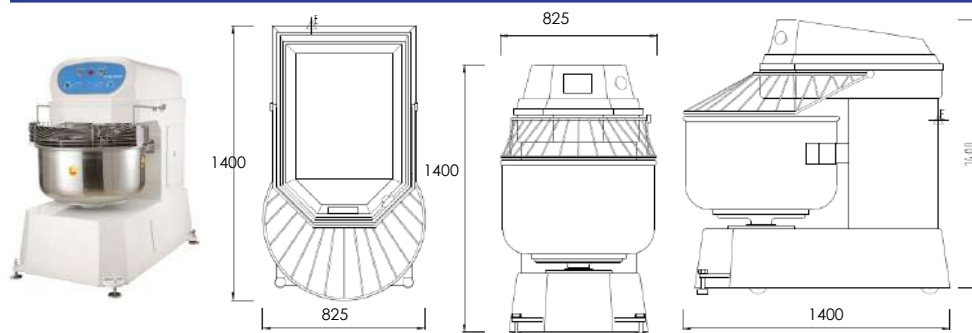

MODEL: 3BAGS75MAE

DIMENSIONS: 825Wx1400Dx1400H

OUTPUT: 8.4 Kw

WEIGHT: 600 kg

- Capacity: maximum 75 kg dry bread flour with 55% water - Computerised touchpad - Variable speed with timer - Safety guard and safety switches - 415V 50Hz 20A 3 Phase



SPIRAL MIXER ACCESSORIES



- Beater attachment to suit Maestro Mix® P10MAE Planetary Mixers
- Beater attachment to suit Maestro Mix® P20MAE Planetary Mixers
- Beater attachment to suit Maestro Mix® P40MAE Planetary Mixers
- Beater attachment to suit Maestro Mix® P60MAE Planetary Mixers
- Beater attachment to suit Maestro Mix® P80MAE Planetary Mixers



- Whisk attachment to suit Maestro Mix® P10MAE Planetary Mixers
- Whisk attachment to suit Maestro Mix® P20MAE Planetary Mixers
- Whisk attachment to suit Maestro Mix® P40MAE Planetary Mixers
- Whisk attachment to suit Maestro Mix® P60MAE Planetary Mixers
- Whisk attachment to suit Maestro Mix® P80MAE Planetary Mixers



- Hook attachment to suit Maestro Mix® P10MAE Planetary Mixers
- Hook attachment to suit Maestro Mix® P20MAE Planetary Mixers
- Hook attachment to suit Maestro Mix® P40MAE Planetary Mixers
- Hook attachment to suit Maestro Mix® P60MAE Planetary Mixers
- Hook attachment to suit Maestro Mix® P80MAE Planetary Mixers



- Bowl attachment to suit Maestro Mix® P10MAE Planetary Mixers
- Bowl attachment to suit Maestro Mix® P20MAE Planetary Mixers
- Bowl attachment to suit Maestro Mix® P40MAE Planetary Mixers
- Bowl attachment to suit Maestro Mix® P60MAE Planetary Mixers
- Bowl attachment to suit Maestro Mix® P80MAE Planetary Mixers

12 LITER HORIZONTAL MIXER

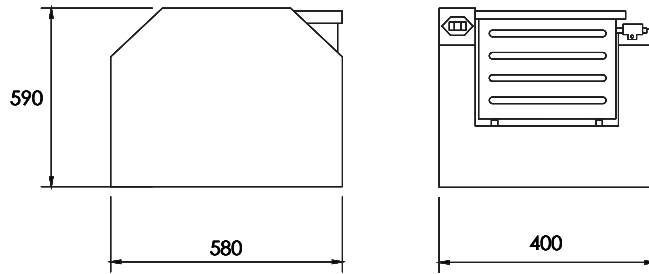

MODEL: HM12
DIMENSIONS: 580Wx400Dx590H
OUTPUT: 1.1 Kw
WEIGHT: 67 kg

- Single phase - 40 – 45 rounds per minute - Stainless steel body - Steel frame with adjustable feet - Forward or reverse operation - Product view window - Safety Switch included



12 LITER HORIZONTAL MIXER WITH HEATING SYSTEM

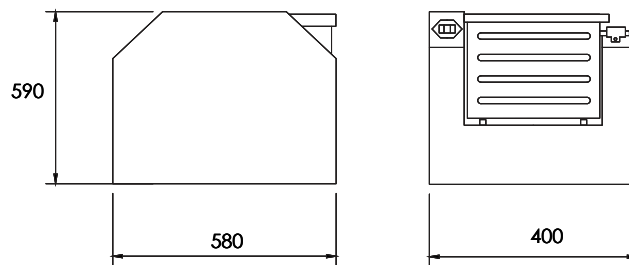

MODEL: HM12-HEAT
DIMENSIONS: 580Wx400Dx590H
OUTPUT: 2.0 Kw
WEIGHT: 67 kg

- Single phase - Time to boil 11 litres approx. 30 minutes - 40 – 45 rounds per minute - Even heat distribution over the bowl, no cold spots - Can individually turn on spinning or heat mode or both - Stainless steel body - Steel frame with adjustable feet - Forward or reverse operation - Product view window - Safety Switch included - 7.5Kg flour capacity.



35 LITER HORIZONTAL MIXER

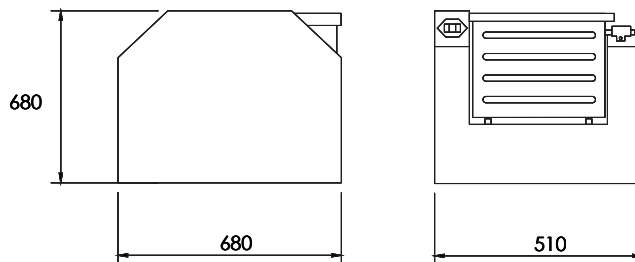

MODEL: HM35
DIMENSIONS: 680Wx510Dx680H
OUTPUT: 1.5Kw
WEIGHT: 80 kg

- Stainless steel body - Steel frame with adjustable feet - Forward or reverse operation - Product view window - Safety Switch included - 240V 10amp 50HZ - 10Kg flour capacity.



50 LITER HORIZONTAL MIXER

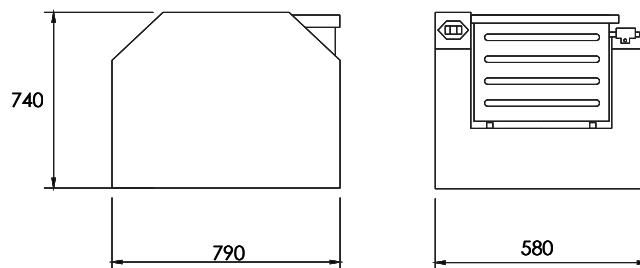

MODEL: HM50
DIMENSIONS: 790Wx580Dx740H
OUTPUT: 2.2 Kw
WEIGHT: 118 kg

- Stainless steel body - Steel frame with adjustable feet - Forward or reverse operation - Product view window - Safety Switch included - 15Kg flour capacity.



Please refer to the Spare Parts and Accessories booklet to see all the available optional extras. "Product" dimensions are given in mm and are approximate. Pictures are for illustrative purposes only. Given information may change without notice. For further information on any line drawings or missing product information, please call our head office on 03 9551 3034. All prices exclude GST. Freight charges apply.

450MM BENCHTOP PASTRY SHEETER

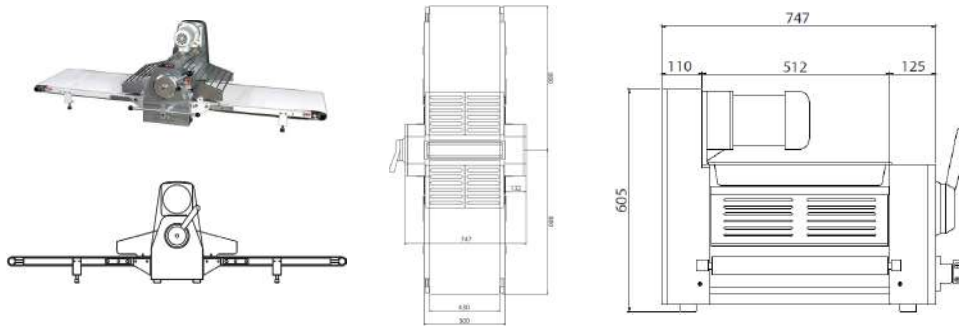

MODEL: PS450BT
DIMENSIONS: 2600Wx750Dx700H
OUTPUT: 2100 W
WEIGHT: 190 kg

- 450mm wide belt - Forward/reverse function - Easy storage - Easy to clean - Includes rolling pin - Safety switches - Emergency stop button - 240V 10A 50Hz-



520MM BENCHTOP PASTRY SHEETER

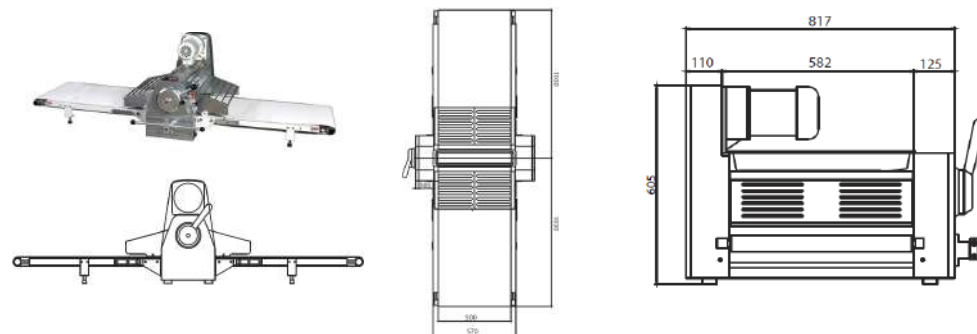

MODEL: PS520BT
DIMENSIONS: 2600Wx900Dx640H
OUTPUT: 0.4 Kw
WEIGHT: 225 kg

- 520mm wide belt - Forward/reverse function - Easy storage - Easy to clean - Includes rolling pin - Safety switches - Emergency stop button - 240V 10A 50Hz



520MM FREESTANDING PASTRY SHEETER

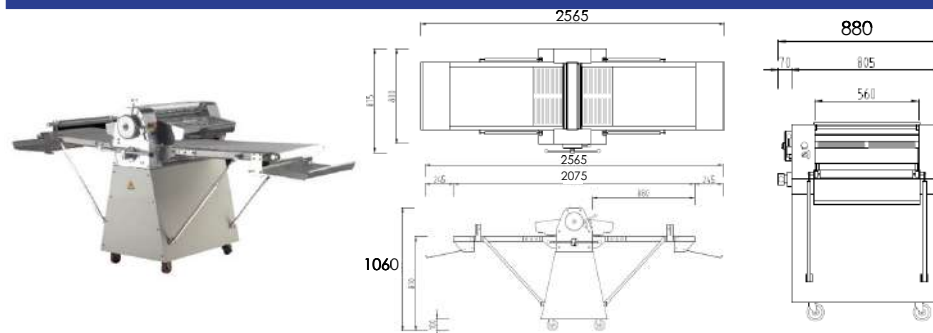

MODEL: PS520FS
DIMENSIONS: 2070Wx880Dx1060H
OUTPUT: 0.55 Kw
WEIGHT: 150 kg

- 520mm wide belt - Stainless steel caps at ends - Foldable bench - Guarded rollers - Folded dimensions: 675Wx880Dx1490H - Forward/reverse function - Easy to clean - Includes rolling pin - Safety switches - Emergency stop button - 240V 10A 50Hz



620MM FREESTANDING PASTRY SHEETER

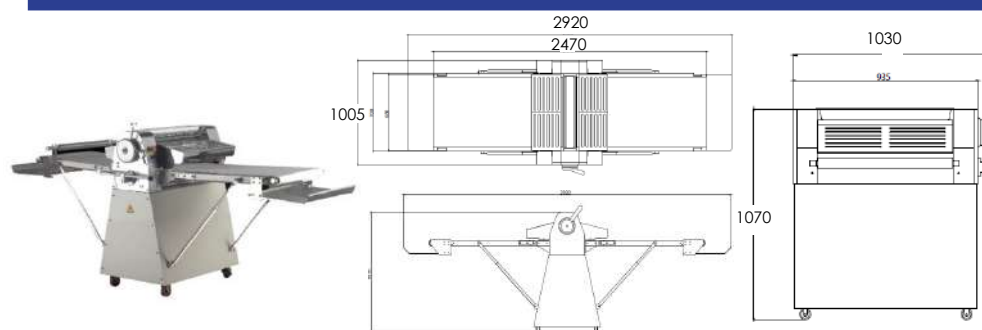

MODEL: PS620FS
DIMENSIONS: 2475Wx1040Dx1170H
OUTPUT: 0.75W
WEIGHT: 150 kg

- 520mm wide belt - Stainless steel caps at ends - Foldable bench - Guarded rollers - Folded dimensions: 675Wx1005Dx1686H - Forward/reverse function - Easy to clean - Includes rolling pin - Safety switches - Emergency stop button - 240V 10A 50Hz



30 PIECE BUN DIVIDER/ROUNDER

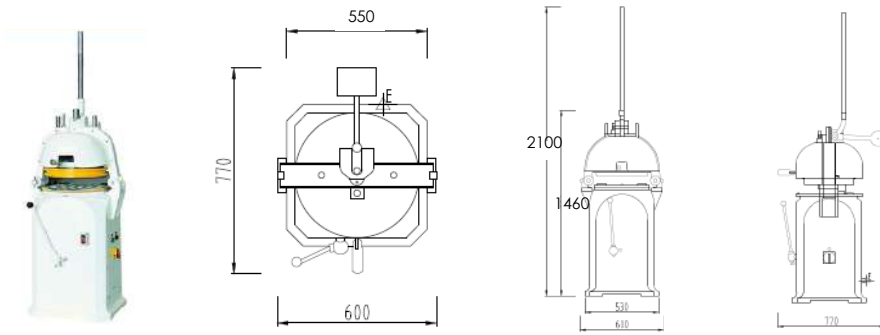

- Capacity: 30 pieces - Includes 3 Tef on plates - Dough weight: 30-100 grams each - 415V 3 Phase + Earth + Neutral 10A 50Hz - Height does not include handle.

MODEL: BD30

DIMENSIONS: 550Wx550Dx1460H

OUTPUT: 0.75 Kw

WEIGHT: 310 kg

MAESTRO MIX

20 PIECE HYDRAULIC DOUGH DIVIDER

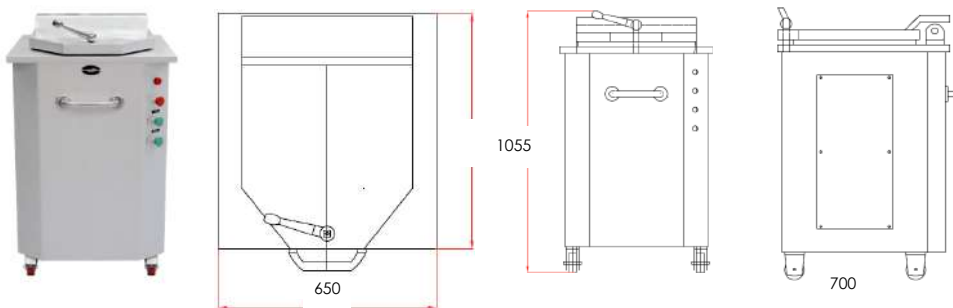

- Capacity: 20 pieces - Max dough weight: 16 kg - Product size: 20 pieces x up to 800g per piece - 415V 3 Phase 10A 50Hz

MODEL: HDD-20

DIMENSIONS: 650Wx700Dx1055H

OUTPUT: 1.1W

WEIGHT: 310 kg

MAESTRO MIX

FREE STANDING ROLL/LOAF MOULDER

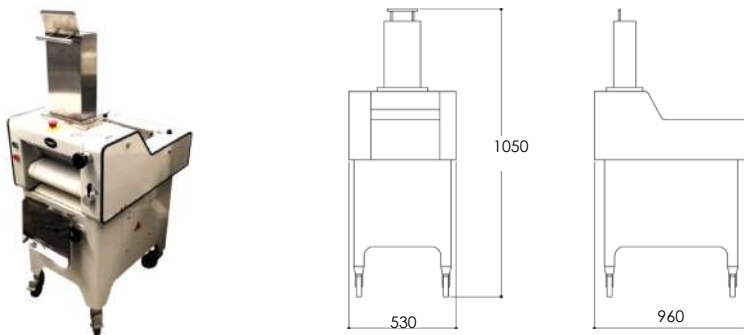

- Adjustable dough hopper - Easy to extract air inside dough - One or two sided operation - Reverse operating device - OH&S compliant safety chute - 240V 10A 50Hz

MODEL: ROL-MOL 280

DIMENSIONS: 530Wx960Dx1050H

OUTPUT: 0.4W

WEIGHT: 145 kg

MAESTRO MIX

UNIVERSAL/FRENCH ROLL MOULDER

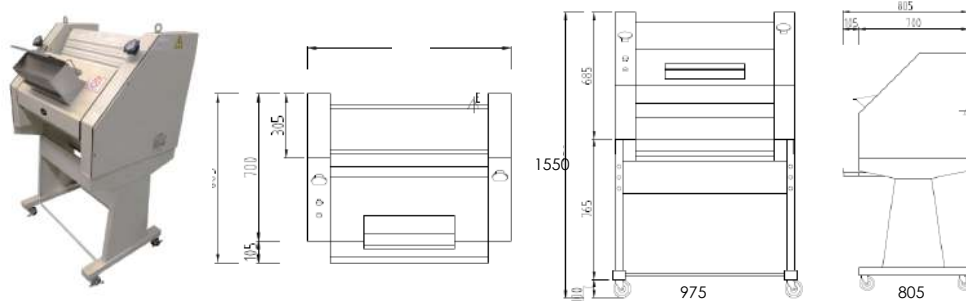

- Felt belt - Dough weight: 50 grams to 1.25 kg each - Safety switch - OH&S compliant safety chute - 415V 3 Phase 10A 50Hz

MODEL: ROL-MOL 750

DIMENSIONS: 975Wx805Dx1550H

OUTPUT: 1 Kw

WEIGHT: 284 kg

MAESTRO MIX

FERMENTING ROOM STEAM GENERATOR

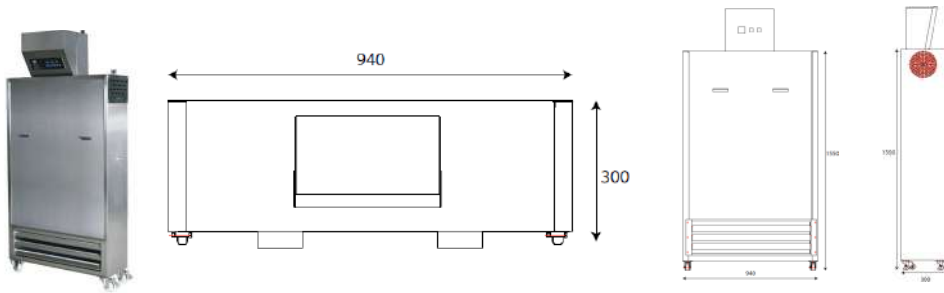

MODEL: FR.SG
DIMENSIONS: 940Wx300Dx1550H
OUTPUT: 9.9 Kw
WEIGHT: 90 kg

- Suited to a variety of rooms - 415V 3 Phase 20A 50Hz



PROVER - 18 TRAY

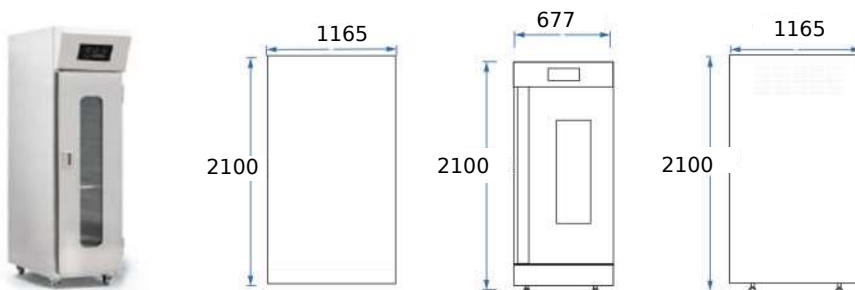

MODEL: RP-18
DIMENSIONS: 677Wx1165Dx2100H
OUTPUT: 1.8 Kw
WEIGHT: 150 kg

- Capacity: 600L - Fit 18 trays (457Wx737D) - Temperature range: -3 °C ~ 40 °C



FERMENTING PROVER - 16 TRAY

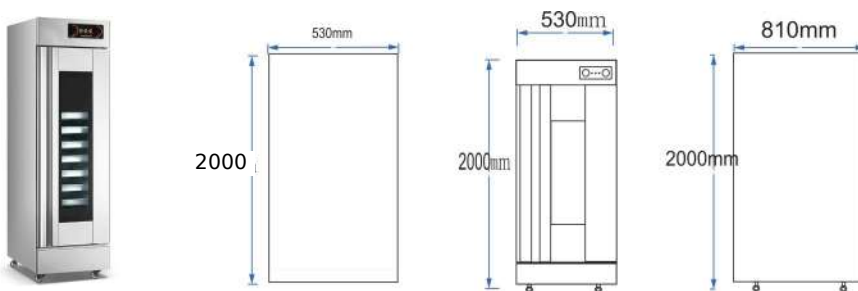

MODEL: FP2-16
DIMENSIONS: 530Wx810Dx2000H
OUTPUT: 2.6 Kw
WEIGHT: 50 kg

- One door - Fits 16 trays (457Wx737D) - Inner dimension for tray (510Wx750D) - Stainless steel shelf, clean and durable, 15 Amp single Phase



FERMENTING PROVER - 32 TRAY

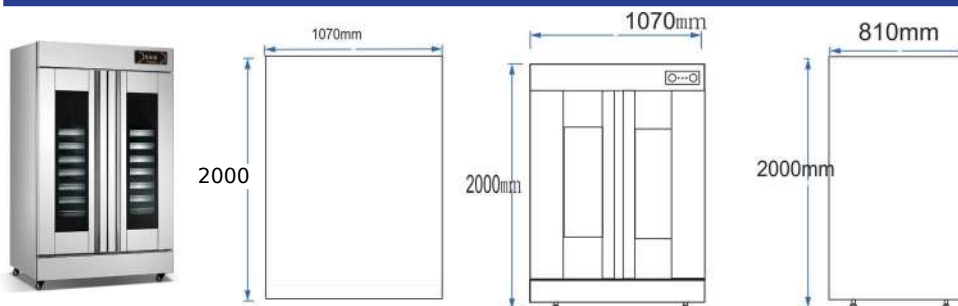

MODEL: FP2-32
DIMENSIONS: 1070Wx810Dx2000H
OUTPUT: 2.8 Kw
WEIGHT: 70 kg

- Two door - Fits 32 trays (457Wx737D) - Inner dimension for tray (510Wx750D) - Stainless steel shelf, clean and durable, 15 Amp single Phase



BENCH MOUNTED BREAD SLICER - 12MM

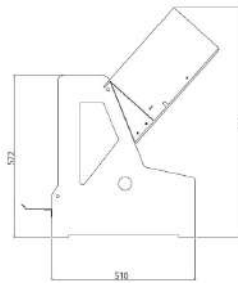
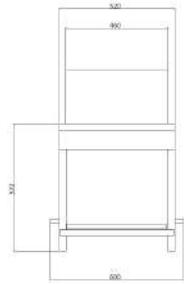

MODEL: BS12

DIMENSIONS: 600Wx780Dx800H

OUTPUT: 0.25 Kw

WEIGHT: 70 kg

- Blade distance/bread slice thickness: 12mm - Includes crumb tray - Durable plastic safety chute - 240V 10A 50Hz-

MAESTRO MIX

BENCH MOUNTED BREAD SLICER - 15MM

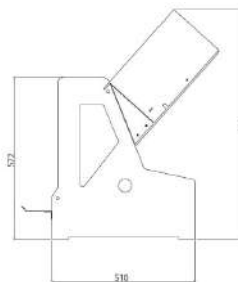
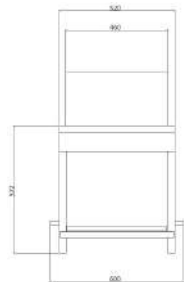

MODEL: BS15

DIMENSIONS: 610Wx780Dx810H

OUTPUT: 0.25 Kw

WEIGHT: 80 kg

Blade distance/bread slice thickness: 15mm - Includes crumb tray - Durable plastic safety chute - 240V 10A 50Hz

MAESTRO MIX



Glass Washers
Under Counter Dishwashers
Pass-through Dishwashers



GLASS WASHER WITH ELECTROMECHANICAL CONTROL PANEL

MADE IN EU

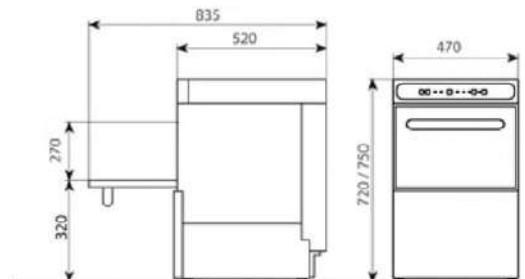

MODEL: EMECH-GW

DIMENSIONS: 470Wx520Dx720H

OUTPUT: 3.06 kW

WEIGHT: 41 kg

- Capacity: 30 baskets/hour - 1 washing cycle: 120 seconds - Tank capacity: 15 litres/2 kW heating power - Boiler capacity: 5 litres/2.8 kW heating power - Wash pump power: 250W - Rinse water consumption : 2.5 litres/rinse - Built in rinse aid dispenser - Anti-backflow valve fitted - Thermostatically adjusted: wash 60°C, and rinse 90°C - Safety thermostat - Supplied with 2 baskets (400mmx400mm), 1 dish bracket and 1 cutlery container - 240V 15A 50Hz.



GLASS WASHER WITH ELECTRONIC CONTROL PANEL

MADE IN EU

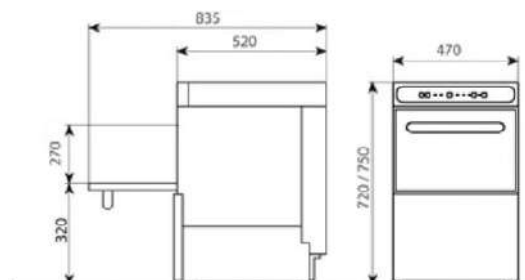

MODEL: HITECH-GW

DIMENSIONS: 470Wx520Dx720H

OUTPUT: 3.06 kW

WEIGHT: 41 kg

- Capacity: 40 baskets/hour - 3 washing cycles: 90/120/180 seconds - Tank capacity: 15 litres/2 kW heating power - Boiler capacity: 5 litres/2.8 kW heating power - Wash pump power: 250W - Rinsing consumption : 2.5 litres/rinse - Built in rinse aid dispenser - Anti-backflow valve fitted - Thermostatically adjusted: wash 60°C, and rinse 90°C - Safety thermostat and thermostop device - Supplied with 2 baskets (400mmx400mm), 1 dish bracket and 1 cutlery container - 240V 15A 50Hz



UNDERCOUNTER DISHWASHER WITH ELECTROMECHANICAL CONTROL PANEL

MADE IN EU

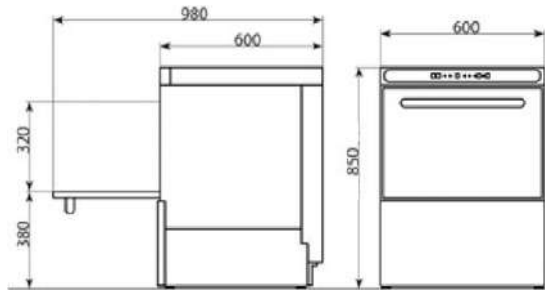
**MODEL:** EMECH-UC500**DIMENSIONS:** 600Wx600Dx820H**OUTPUT:** 3.4 kW**WEIGHT:** 54 kg

- Capacity: 30 baskets/hour - 1 washing cycle of 120 seconds - Tank capacity: 25 litres/2.8 kW heating power
 - Boiler capacity: 7 litres/2.8 kW heating power - Wash pump power: 600W - Rinse water consumption: 2.7 litres/rinse - Built-in rinse aid dispenser and detergent dispenser - Anti-backflow valve fitted - Safety thermostat - Temperatures adjusted: 60°C (Wash)/90°C (Rinse) - Supplied with 2 baskets (500mmx500mm) and 4 cutlery baskets - 240V 15A 50Hz



UNDERCOUNTER DISHWASHER WITH ELECTRONIC CONTROL PANEL

MADE IN EU

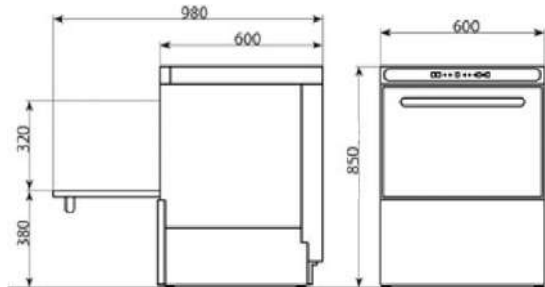
**MODEL:** HITECH-UC500**DIMENSIONS:** 600Wx600Dx820H**OUTPUT:** 3.4 kW**WEIGHT:** 54 kg

- Capacity: 40 baskets/hour - 3 washing cycles of 60/90/180 seconds - Tank capacity: 25 litres/2.8 kW heating power - Boiler capacity: 7 litres/2.8 kW heating power - Wash pump power: 600W - Rinse water consumption: 2.7 litres/rinse - Built-in rinse aid dispenser and detergent dispenser - Anti-backflow valve fitted - Safety thermostat - Temperatures adjusted: 60°C (Wash)/90°C (Rinse) - Supplied with 2 baskets (500mmx500mm) and 4 cutlery baskets - 240V 15A 50Hz



PASSTHROUGH DISHWASHER WITH ELECTROMECHANICAL CONTROL PANEL

MADE IN EU

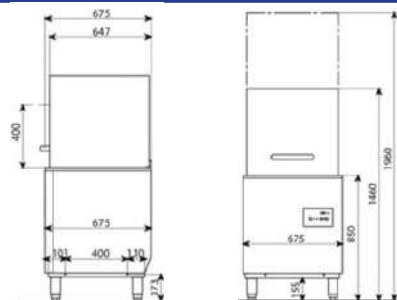

MODEL: EMECH-PT500

DIMENSIONS: 675Wx675Dx1440/1960H

OUTPUT: 11.1 kW

WEIGHT: 108 kg

- Capacity: 40 baskets/hour - 2 washing cycles: 90/180 seconds - Tank capacity: 45 litres/4.5 kW heating power - Boiler capacity: 7 litres/6 kW heating power - Wash pump power: 600W - Rinse water consumption: 3 litres/rinse - Built in rinse-aid dispenser, detergent dispenser and drain pump - Anti-backflow valve fitted - Safety thermostat - Temperatures adjusted: wash 60°C/rinse 90°C - Supplied with 2 baskets (500mmx500mm) and 2 cutlery baskets - 415V 25A 50Hz

PASSTHROUGH DISHWASHER WITH ELECTRONIC CONTROL PANEL

MADE IN EU

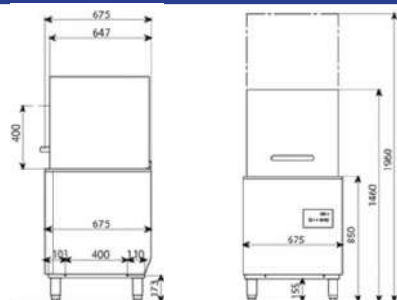

MODEL: HITECH-PT500

DIMENSIONS: 675Wx675Dx1440/1960H

OUTPUT: 11.1 kW

WEIGHT: 108 kg

- Capacity: 40 baskets/hour - 2 washing cycles: 90/180 seconds - Continuous cycle up to the manual stop - Tank capacity: 45 litres/4.5 kW heating power - Boiler capacity: 7 litres/6 kW heating power - Wash pump power: 600W - Rinse water consumption: 3 litres/rinse - Built in rinse-aid dispenser, detergent dispenser and drain pump - Anti-backflow valve fitted - Safety thermostat - Temperatures adjusted: wash 60°C/rinse 90°C - Supplied with 2 baskets (500mmx500mm) and 2 cutlery baskets - 415V 25A 50Hz



CHARCOAL ROTISSERIES

12 Rod Charcoal Chicken Rotisserie

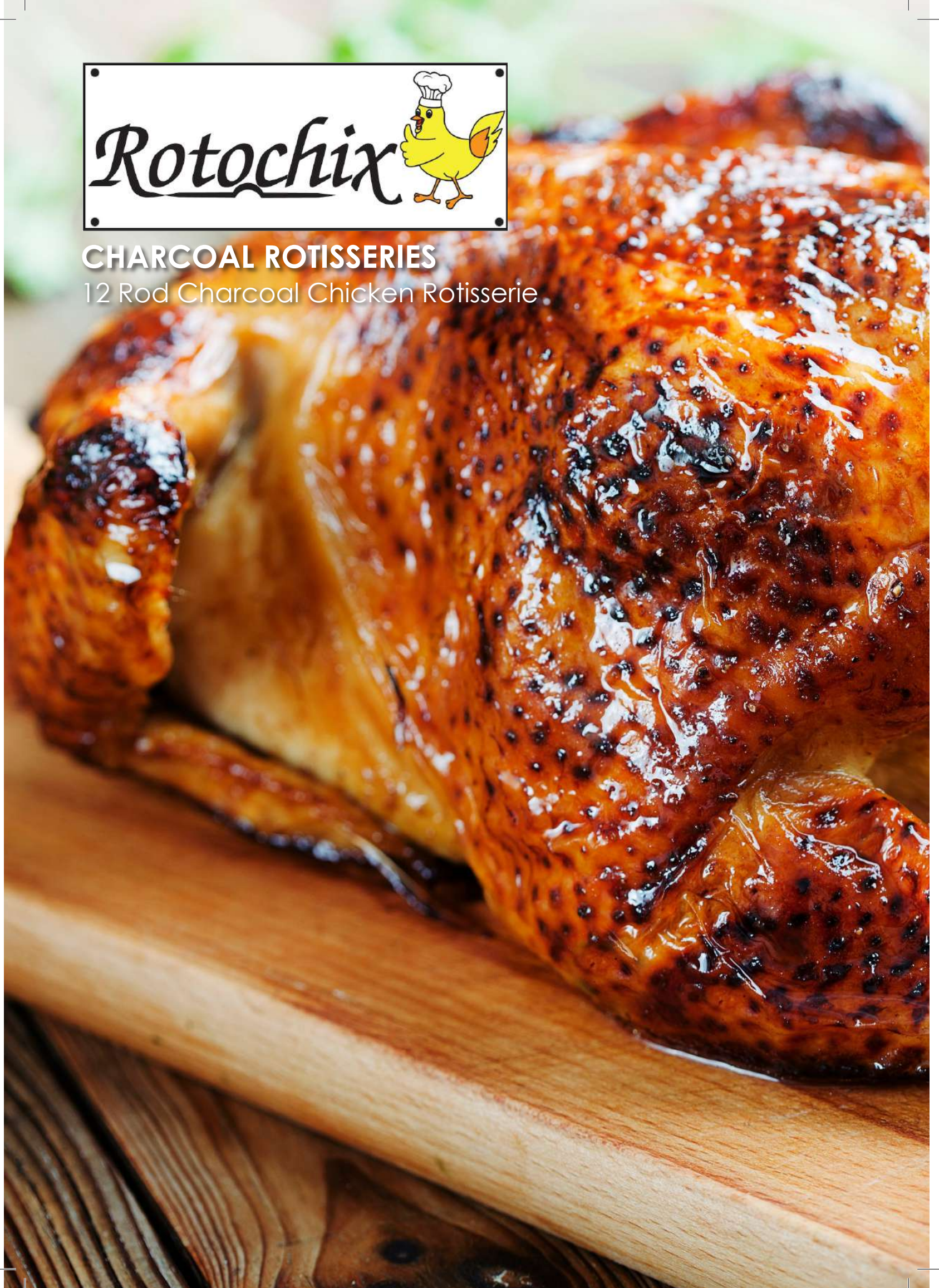

9 ROD CHARCOAL CHICKEN ROTISSERIE

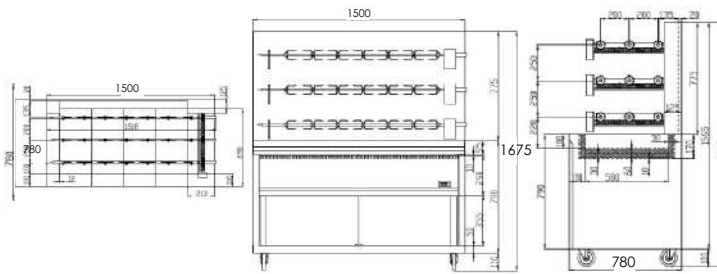

MODEL: 9RODS

DIMENSIONS: 1500Wx780Dx1675H

OUTPUT: N/A

WEIGHT: 350 kg

- Storage cabinet underneath - 3 tiers/3 rods per tier - Refractory stone base - 3 independent chains - 9 rods included - Capacity: 54 chickens - 240V 10A 50Hz



12 ROD CHARCOAL CHICKEN ROTISSERIE

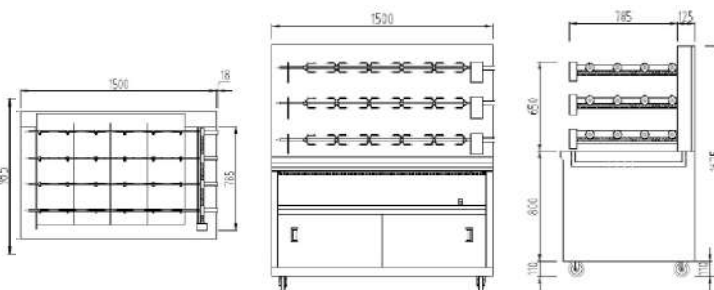

MODEL: 12RODS

DIMENSIONS: 1500Wx980Dx1675H

OUTPUT: N/A

WEIGHT: 450 kg

- Storage cabinet underneath - 3 tiers/4 rods per tier - Refractory stone base - 3 independent chains - 12 rods included - Capacity: 72 chickens - 240V 10A 50Hz



GAS CHICKEN/GIROS ROTISSERIE SMALL

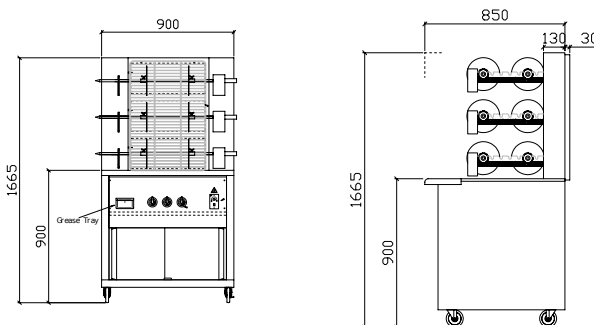

MODEL: GR-900

DIMENSIONS: 900Wx850Dx1665H

OUTPUT: 125 MJ/h (NG)

WEIGHT: 180 kg

- Best of both worlds! Charcoal tray in a Gas Rotisseries cooks upto six rods of chicken or giros at anytime with added charcoal flavour, Storage cabinet underneath.



GAS CHICKEN/GIROS ROTISSERIE LARGE

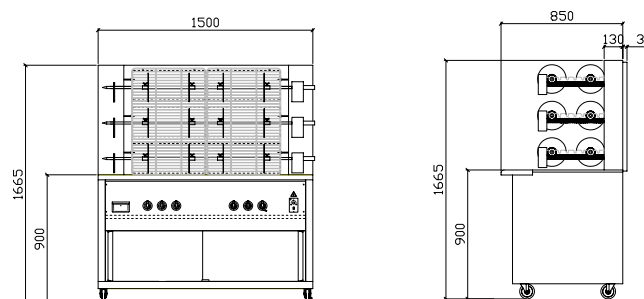

MODEL: GR-1500

DIMENSIONS: 1500Wx850Dx1665H

OUTPUT: 250 MJ/h (NG)

WEIGHT: 250 kg

- Best of both worlds! Charcoal tray in a Gas Rotisseries cooks upto six rods of chicken or giros at anytime with added charcoal flavour, Storage cabinet underneath.



ACCESSORIES



OXFORD ACCESSORIES



- Wire basket to suit 6BASKET-NC

MODEL: OXFORD WIRE BASKET FOR 6 BASK

DIMENSIONS: Ø150x300H



- Stackable rings to suit STEAMER 800

MODEL: ST-RING

DIMENSIONS: Ø510Wx95H



- Cover for stackable rings to suit STEAMER 800

MODEL: ST-COVER

DIMENSIONS: Ø510x105H



- Cheong Fun steamer to suit 6BASKET-NC

MODEL: CHFUN-ST

DIMENSIONS: 450Wx560Dx210D



- 5 tier steamer and cover set to suit STEAMER 800

MODEL: ST-STEAMER 5 TIER SET + COVER

DIMENSIONS: Ø510Wx580H

- Leg braces to suit RCGD series chargrills and hotplates

MODEL: RCGD BBQ LEG BRACE

DIMENSIONS: VARIOUS



MODEL: FP400

DIMENSIONS: 430Wx290H

PRICE: \$120

Fish Plate to suit GFC400 and GFC600 fryers



MODEL: FP600

DIMENSIONS: 490Wx430H

WOK ACCESSORIES

- Knee operated tap to suit all Oxford Wok products

MODEL: KNEE OPERATED TAP

WEIGHT: 1 kg



- Wok adaptor to suit larger 17" woks. Adaptor ring is **not required** for SuperWok models

MODEL: ADAPTOR RING

WEIGHT: 10 kg



- Chimney burner to suit WOK888 wok burners

MODEL: CHIMNEY BURNER

WEIGHT: 5 kg



- Duckbill burner to suit WOK888 wok burners

MODEL: DUCKBILL BURNER

WEIGHT: 5 kg



- Super Chimney Burner to suit SuperWok

MODEL: SUPER CHIMNEY BURNER

WEIGHT: 5 kg

ROYSTON ACCESSORIES



- Fryer basket to suit FRY-101 and FRY-102 series benchtop fryers - Heavy duty insulated handles

MODEL: FRY-BASKET

DIMENSIONS: 190Wx440Dx125H



- Cup to suit MS- Series Milk Shake Makers - High quality polycarbonate construction

MODEL: MS-PCUP

DIMENSIONS: 115Wx115Dx160H



- Cup to suit MS- Series Milk Shake Makers - High quality stainless steel construction

MODEL: MS-SSCUP

DIMENSIONS: 113Wx113Dx162H

ROYSTON KEBAB MACHINE ACCESSORIES

- Kit includes gas hose, plate wire, clips, 900mm long class D hose, AGA approval number 7854, 1/2 BSP MALE one side and 1/2 BSP NUTANDCONE on the other side

MODEL: INSTALLATION KIT

MITCHEL ACCESSORIES



- Glass doors to suit UB320-R, UB500-R, UB645-R

MODEL: GLASS DOORS

DIMENSIONS: 455Wx50Dx670H

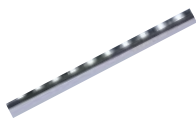

- LED lights to suit UB320-R, UB500-R, UB645-R

MODEL: LED LIGHTS

DIMENSIONS: 750Wx20Dx20H



- Shelves to suit GN or GLA series refrigerators and freezers

MODEL: SHELF

DIMENSIONS: NA



- Shelf runners to suit GN series refrigerators and freezers

MODEL: SHELF RUNNERS

DIMENSIONS: NA

KSS ACCESSORIES



- Castors with brakes to suit 02- range of stainless steel benches - Heavy duty build - Non-marking

MODEL: BENCH CAS/BRAKE

DIMENSIONS: Ø100x27D

- Black Plastic Bush Insert Stopper to Suit Bench Leg

MODEL: BENCH BLACK INSERT

DIMENSIONS: 32Wx32Dx50H



- Stainless steel wire racks - Suits KSS Gastronorm trolleys - Ideal for use with steamers/combis

MODEL: WIRE RACKS GN 1/1

DIMENSIONS: 325Wx530D

TITAN ACCESSORIES



- Castors with brakes to suit Titan plastic mat and wire shelving units

MODEL: TITAN CASTORS

DIMENSIONS: 100Wx50Dx180H



- Hook suited for Titan shelves for corner postless assembly

MODEL: TITAN HOOK

DIMENSIONS: 15Wx25Dx25H



- Post with bolt floor: for standard installation

MODEL: TITAN POST

DIMENSIONS: 30Wx30Dx1825H



- Black shelf clips (pair) to suit Titan shelving units

MODEL: TITAN CLIPS

DIMENSIONS: 31 Wx31Dx45H

AMALFI ACCESSORIES



- Oven stones to suit Amalfi Series oven range - Stones sold individually

MODEL: Oven Stone

DIMENSIONS: 430Wx630Dx18H

MAESTRO MIX ACCESSORIES



- ⊗ Beater attachment to suit Maestro Mix P10MAE Planetary Mixers
- ⊗ Beater attachment to suit Maestro Mix P20MAE Planetary Mixers
- ⊗ Beater attachment to suit Maestro Mix P40MAE Planetary Mixers
- ⊗ Beater attachment to suit Maestro Mix P60MAE Planetary Mixers
- ⊗ Beater attachment to suit Maestro Mix P80MAE Planetary Mixers



- ⊗ Whisk attachment to suit Maestro Mix P10MAE Planetary Mixers
- ⊗ Whisk attachment to suit Maestro Mix P20MAE Planetary Mixers
- ⊗ Whisk attachment to suit Maestro Mix P40MAE Planetary Mixers
- ⊗ Whisk attachment to suit Maestro Mix P60MAE Planetary Mixers
- ⊗ Whisk attachment to suit Maestro Mix P80MAE Planetary Mixers



- ⊗ Hook attachment to suit Maestro Mix P10MAE Planetary Mixers
- ⊗ Hook attachment to suit Maestro Mix P20MAE Planetary Mixers
- ⊗ Hook attachment to suit Maestro Mix P40MAE Planetary Mixers
- ⊗ Hook attachment to suit Maestro Mix P60MAE Planetary Mixers
- ⊗ Hook attachment to suit Maestro Mix P80MAE Planetary Mixers



- ⊗ Bowl attachment to suit Maestro Mix P10MAE Planetary Mixers
- ⊗ Bowl attachment to suit Maestro Mix P20MAE Planetary Mixers
- ⊗ Bowl attachment to suit Maestro Mix P40MAE Planetary Mixers
- ⊗ Bowl attachment to suit Maestro Mix P60MAE Planetary Mixers
- ⊗ Bowl attachment to suit Maestro Mix

ROTOCHIX ACCESSORIES



- Rotisserie basket to suit 9RODS or 12RODS rotisseries - Suitable for fish, steaks, vegetables etc

MODEL: ROT-BASKET

DIMENSIONS: 1530Wx150Dx56H

TERMS AND CONDITIONS OF SALE

1. INTERPRETATION

In these terms and conditions:

- 1.1 "Products" means the good(s) (whether 'made-to-order' or customised goods manufactured by the Seller, 'off-the-shelf' or standard goods manufactured by the Seller or a 3rd party, and / or new or used goods) and or service(s) described overleaf.
- 1.2 "Seller" means CONCORDE FOOD EQUIPMENT WHOLESALERS PTY LTD (A.B.N 86 547 310 979).
- 1.3 "Buyer" means the purchaser of the Products specified overleaf

2. APPLICABILITY OF THESE TERMS AND CONDITIONS

- 2.1 These terms and conditions apply to all sales of Products by the Seller to the Buyer and constitute all the terms agreed between them to the exclusion of all other terms and conditions. Any conditions contained in any order or other document submitted by the Buyer are hereby expressly excluded.
- 2.2 The descriptions, illustrations and performances contained in the Seller's catalogues, price lists and other advertising matter do not form part of the contract of sale of the Products or of the description applied to the Products. The Buyer accepts all responsibility for ensuring that the Products it selects at the time of purchase are fit for their intended purpose and releases the Seller from any responsibility over recommendations made by the Seller at or before the time of purchase.
- 2.3 Upon any payment on this invoice, the buyer agrees to all parts of the seller's terms and conditions of sale, irrespective of signature acknowledgement or not.

3. PRICE AND PAYMENT

- 3.1 Prices quoted by the Seller are ex-Seller's premises exclusive of GST and are subject to change at any time without notice and are not binding on the Seller.
- 3.2 Payment of the price of the Products (plus any applicable freight or delivery charges and GST and any other taxes, duties or imposts) must be made in clear funds at the times and in the manner described overleaf and in all cases must be fully made prior to delivery, installation or collection (unless otherwise agreed in writing by the Seller). If payment of a deposit is indicated as being required overleaf, the deposit shall be non-refundable to the extent permitted by law.
- 3.3 If the Buyer has an approved credit account with the Seller, the Products supplied must be paid for within the approved credit terms. Where the Buyer is overdue with any payment of any approved credit account, the Seller (without prejudice to its other rights) reserves the right to change the Buyer to a 'cash on delivery' ("COD") account or to cease supplying further Products to the Buyer.
- 3.4 Without prejudice to any other remedy, the Seller reserves the right to charge interest on any overdue invoices at an annual rate prescribed from time to time under section 2 of the *Penalty Interest Rates Act 1983*.
- 3.5 The seller's terms and conditions apply to all third party invoicing, including but not limited to invoices in the name of; financial institutions, insurance companies, builders, shop fitters, resellers etc.

4. SHIPPING AND DELIVERY

- 4.1 Whilst the Seller will use all reasonable endeavours to meet proposed delivery times, the delivery times made known to the Buyer are estimates only given in good faith and the Seller is not liable for late delivery or non-delivery. The Seller is not liable for any loss, damage or delay (including consequential losses) occasioned to the Buyer or its customers arising from late or non-delivery or late installation of the Products. The seller recommends the buyer to take out relevant insurance.
- 4.2 Unless otherwise agreed in writing by the Seller, delivery terms shall be ex-Seller's premises.
- 4.3 The Seller is not responsible to the Buyer or any person claiming through the Buyer for any loss or damage to the Products in transit caused by any event of any kind by any person (whether or not the Seller is legally responsible for the person who caused or contributed to that loss or damage). The Products are at the risk of the Buyer as soon as they are dispatched or collected from the Seller's premises.

5. RETENTION OF TITLE & PPSA

- 5.1 This clause 5 applies to any good(s) forming part of the sale of the Products described overleaf and or to any good(s) forming part of the sale of any Products by the Seller to the Buyer in the future ("the Goods").
- 5.2 Ownership of, or title in, the Goods remains with the Seller and will not pass to the Buyer until the Buyer has paid the Seller in full for the Products under all individual contracts for the supply of Products between the Seller and the Buyer, and the Buyer has discharged all outstanding indebtedness under these terms and conditions, whether in respect of the Products or otherwise, to the Seller.
- 5.3 Until the Goods are sold or otherwise used by the Buyer in the ordinary course of the Buyer's business, the Buyer must keep the Goods safe and clearly designate the Goods as the property of the Seller. If the Goods are sold or otherwise used, altered or comingled with other goods by the Buyer, then the proceeds of sale of each item of the Goods must be held by the Buyer in a separate fund on trust for the Seller and the Buyer must account to the Seller for such proceeds. The Buyer hereby irrevocably grants the Seller the right to enter the Seller's premises or vehicles to inspect the Goods and retake possession of any Goods and otherwise exercise any rights in relation to the Goods conferred by common law, statute or contract.

5.4 PPSA

5.4.1 In this clause 5.4:

- (i) PPSA means the Personal Property Securities Act 2009 (Cth) as amended from time to time;
- (ii) a term used in this clause 5.4 has the same meaning as in the PPSA.

5.4.2 In consideration of the Seller supplying the Goods to the Buyer at the request of the Buyer, the Buyer:

- (i) grants to the Seller, at the Seller's discretion, a security interest or purchase money security interest (PMSI) in the Goods;
- (ii) agrees that any of the Goods or proceeds of sale of the Goods coming into existence after the date of these terms and conditions or the date of this invoice (as the case may be) will come into existence subject to the security interest or PMSI granted in these terms and conditions without the need for any further action or agreement by any party;
- (iii) agrees that the Buyer has received valuable consideration from the Seller and that such consideration is sufficient;
- (iv) agrees that the security interest or PMSI has attached or will attach to all Goods supplied now or in the future to the Buyer when the Buyer takes possession of the Goods and that the attachment of the security interest or PMSI has not in any way

been deferred or postponed from the date of these terms and conditions or the date of this invoice (as the case may be).

- 5.4.3 The Seller may, by notice to the Buyer at any time, require the Buyer to take all steps that the Seller considers necessary or desirable to:
 - (i) ensure that these terms and conditions or any security interest or PMSI arising under them, are enforceable against the Buyer or any third party;
 - (ii) protect, perfect, record, or better secure the position of the Seller under these terms and conditions as a first ranking security.
- 5.4.4 The Seller reserves the right to register a financing statement in respect of any Goods supplied by the Seller to the Buyer under these terms.
- 5.4.5 The cost and expense of registering a financing statement or a financing change statement is to be paid by the Buyer and may, where applicable, be debited against the Buyer's credit account with the Seller or included in this invoice as a separate charge.
- 5.4.6 The Buyer:
 - (i) waives the right to receive a copy of any notice, verification statement confirming registration of a financing statement or a financing change statement relating to the security interest or PMSI under these terms and conditions, unless the notice or statement is required by law and cannot be excluded;
 - (ii) agrees to comply with any notice from the Seller under this clause 5.4 at the Buyer's cost and expense.
- 5.4.7 The Buyer agrees:
 - (i) not to allow any person to register a financing statement over any of the Goods supplied by the Seller without the prior written consent of the Seller;
 - (ii) that it must immediately notify the Seller if it becomes aware of any person taking steps to register a financing statement in relation to the Goods.

6. WARRANTY

- 6.1 To the extent permitted by law, the Seller's liability for a breach of any express and implied warranties, guarantees and conditions under statute or general law (including but not limited to a breach of a guarantee implied by Division 1 of Part 3-2 of the Australian Consumer Law) in relation to any Products manufactured by the Seller is limited to making good any defects by repairing the defects or at the Seller's option by replacement, within a period not exceeding:
 - (a) in the case of new Products - twelve (12) calendar months; (unless specified) some products do not carry a full 12-month warranty on parts or labour.
 - (b) in the case of used Products - three (3) calendar months, (unless specified) after the earlier of: The Products being dispatched to/collected by the Buyer; and the date of the Seller's invoice for the Products, and so long as:
 - (i) defects have arisen solely from faulty materials or workmanship;
 - (ii) the Products have not received maltreatment, inattention or interference and have been used, serviced and maintained by the Buyer in accordance with the Seller's specifications and recommendations;
 - (iii) accessories of any kind used by the Buyer are manufactured by or approved by the Seller;
 - (iv) the seals of any kind on the Products remain unbroken; and
 - (v) the Seller's authorised representative has inspected the Products and has determined that a defect exists.
 - (vi) manufacturer warranty applies to Australian capital cities, remote, country and regional areas will incur extra charges. Counter line is return to base warranty.
- 6.2 Consumables such as globes, thermo couples, door seals and the like are not covered by the warranty in clause 6.1.
- 6.3 If any of the Products are not manufactured by the Seller the guarantee of the manufacturer of those Products is accepted by the Buyer and is the only guarantee given to the Buyer in respect of those Products. The Seller agrees to assign to the Buyer on request made by the Buyer the benefit of any warranty or entitlement to those Products that the manufacturer has granted to the Seller under any contract or by implication or operation of law to the extent that the benefit of any warranty or entitlement is assignable.
- 6.4 Except as provided in these terms and conditions and to the extent permitted by law, all express and implied warranties, guarantees and conditions under statute or general law as to merchantability, description, quality, suitability or fitness of the Products for any purpose or as to design, assembly, installation, materials or workmanship or otherwise are expressly excluded. The Seller is not liable to the Buyer or and third party for physical or financial injury, loss or damage or for special, indirect, consequential or punitive loss or damage of any kind (including but not limited to loss of profits or loss of business) (and even if notified of the possibility of such loss or damage) arising out of the supply, layout, assembly, installation or operation of the Products or arising out of the Seller's negligence or in any way whatsoever.
- 6.5 Warranty is Mon - Fri 8.30am to 5.00pm. Repairs from any third party contractors must be approved by the seller, and the seller will not reimburse the buyer, or settle any repair invoices unless prior approval by the seller.

7. CHANGED OR DISCONTINUED PRODUCT

- 7.1 The Buyer acknowledges that over time, the Seller's products may undergo update and revision. As a result, there may be some differences between what is advertised / supplied to the Buyer and the specifications and description of the Products at the time the Seller submits its quotation and or the time the Buyer submits its Order. All reasonable care has been taken to ensure that prices are correctly printed and advertised at the time. The company reserves the right to not honour any prices shown as a result of pricing or advertising error.

8. RETURNS

- 8.1 The Seller is not under any duty to accept Products returned by the Buyer and will do so only on terms determined by the Seller (including a 30% re-stocking fee for 'off-the-shelf' or standard Products) in each individual case.
- 8.2 Without limiting the generality of clause 8.1, in no case shall the Seller accept the return of Products which are 'made-to-order', customised, used or damaged, or have been sourced from overseas. Further, in the case of any Product, the Seller shall not accept any claim for return by the Buyer if the claim is not made within 7 days of delivery or collection of the Products.
- 8.3 If the Seller agrees to accept returned Products from the Buyer under clause 8.1, the Buyer must return the Products to the Seller at the Seller's place of business.
- 8.4 If the Seller agrees to accept returned Products from the Buyer under clause 8.1, the Buyer must return the Products to the Seller in original packaging. No returns will be accepted if products are not in perfect condition.